

## Australian examples of residential Integrated Water Cycle Planning — Accepted current practice and a suggested alternative

I.M. Brodie

*Faculty of Engineering and Surveying, University of Southern Queensland, West Street, Toowoomba, 4350, Queensland, Australia  
Tel. +61 (7) 46312519; Fax +61 (7) 46312592; email: brodiei@usq.edu.au*

Received 7 May 2009; Accepted in revised form 4 October 2009

---

### ABSTRACT

Australian examples of Integrated Water Cycle Planning (IWCP) for residential development demonstrate that providing multiple household-water connections is a generally accepted practice. These connections typically include a potable mains supply, a separate non-potable supply utilising reclaimed water and/or a household roofwater tank for non-potable uses. Stormwater is not fully exploited as a potential urban water source. The advent of national guidelines for using recycled water for drinking purposes is expected to simplify IWCP towards a single-line household-water supply reclaimed from a range of different sources. An IWCP approach is suggested in this paper based on a single household supply complemented by: 1) potential separation of blackwater to reduce human health risk and to enhance community acceptance of recycled water, 2) the use of water sensitive urban design requirements of storing and slowly releasing urban stormwater, and 3) taking advantage of economies of scale by integrating communal roofwater tanks into the urban stormwater system.

*Keywords:* Integrated water resources management; Water recycling; Water reuse; Water resources; Stormwater

---

### 1. Introduction

Integrated water cycle planning (IWCP) is “a way of managing water in which all components of the water system are integrated so that the use of the water resource and impact on other resources and users is minimised” [1]. IWCP means that the three main urban services (water supply, sewerage and stormwater) should be planned and managed together. Similar terms in use include integrated urban water management and integrated water cycle management. Urban areas with 1000–10,000 connections are suggested to be the optimal scale at which the benefits of IWCP are realised [2,3].

This paper considers Australian IWCP practices for residential developments and subdivisions. In particu-

lar, an alternative strategy to the current and generally accepted practice of using dual reticulation (sometimes referred to as ‘purple pipe’) to provide non-potable water at a household level is suggested and discussed.

### 2. Current Australian IWCP practice

Due to widespread water shortages, a desire for sustainable urban growth and concerns about climate change, the concept of IWCP has gained considerable favour within the Australian water industry. This has led to the implementation of new kinds of urban water supply systems that treat and reuse ‘spent’ water previously considered to be waste. In this way, water is used multiple

times rather than the traditional flow-through convention of water supply-use-treat-disposal to the environment. To enact on IWCP requires literally closing the loop in the urban water network, such that spent water is reclaimed, sent back to the household and reused.

To build a picture of current Australian IWCP practice for residential subdivisions, reference can be made to reviews of projects (>100 households) that are either operational, or being planned [4,5]. A summary of relevant projects is provided in Table 1, profiling key water cycle features at the household level. The various types of water require definition, as follows: 'roofwater' is the surface flow from roofs during rainfall — also commonly referred to as 'rainwater', 'blackwater' is spent water from the household toilet and kitchen, 'greywater' is spent water from the household bathroom and laundry, and 'stormwater' is the surface flow during rainfall from urban surfaces other than roofs, dominated by impervious surfaces such as roads, driveways and carparks. 'External water' (or 'mains water') is water sourced externally from the project area by more conventional means such as dams and groundwater extraction.

In all cases given in Table 1, a separate external water supply is needed to service household potable water demand which is typically 14% of total water use [6]. Overall usage of high quality potable water is reduced by direct substitution with a lesser quality, but fit-for-purpose water to meet non-potable needs such as toilet flushing and garden watering. Reduction targets in potable water usage for the selected IWCP projects range from 20 to 70%.

Table 1 also shows how blackwater, greywater, roofwater and stormwater are combined together and reused (or used) within each project. At Homebush Bay, for example, sewage (blackwater and greywater) is treated and

mixed with stormwater, further treated and reticulated to the neighbouring suburb of Newington for non-potable uses [7]. A similar approach is used at Mawson Lakes, South Australia. Reclaimed water from treated sewage only is provided by dual reticulation at Rouse Hill, Aurora and Pimpama Coomera. At the latter two sites, the non-potable water supply is supplemented at each household by connection to a roofwater tank. Blackwater separation is practiced at Inkerman D'Lux as greywater, stormwater and roofwater are combined and treated for toilet flushing and garden irrigation.

Although variations are found in the Australian examples, typical features of the generally accepted IWCP practice for residential development are shown schematically as a flow diagram (Fig. 1).

On the 'supply' side of the water cycle, a trend towards multiple (up to three) supply connections to the household is evident including 1) a potable mains supply, 2) a non-potable supply of reclaimed water generally from treatment of sewage (blackwater and greywater) sometimes mixed with stormwater — this connection is commonly referred to as 'purple pipe', and 3) a non-potable supply utilising roofwater stored in an onsite tank connected to the house. Treatment of roofwater is typically minimal and may rely on in-tank settling and heating by the household hot water system to remove some pathogens.

The trend of providing an increasing number of household supply connections appears to have evolved from a general acceptance within the water industry of dual non-potable or purple pipe reticulation. The provision of a separate urban water supply of a non-drinking quality has a long history overseas dating from 1912 when reclaimed water was used to irrigate lawns and supply ornamental

Table 1  
Water cycle profiles of Australian residential developments using IWCP practices

Project	Type of development	Uses of water types				
		Ext.	Black	Grey	Storm	Roof
Rouse Hill, Sydney	Major urban area (35,000 homes)	P	NP	NP	—	—
Homebush Bay, Sydney	Medium density (2400 homes)	P	NP	NP	NP	—
Kogarah Town Square, Sydney	Medium density (194 apartments)	P	—	—	(NP)	NP
Inkerman D'Lux, Melbourne	Medium density with retail (236 apartments)	P	—	NP	NP	NP
Mawson Lakes, Adelaide	Low density, multi-land use (4000 homes)	P	NP	NP	NP	—
Aurora, Melbourne	Mixed density (8455 homes)	P	NP	NP	—	NP
Pimpama Coomera, Gold Coast	Major urban area (150,000 residents)	P	NP	NP	—	NP

Legend: P = Potable water supply plumbed for internal household use, NP = Non-potable uses including plumbed for internal household use, (NP) = Non-potable for outside uses only, e.g. garden irrigation, — = not reused, or in the case of roofwater, not a mandatory or fully integrated feature of the project.

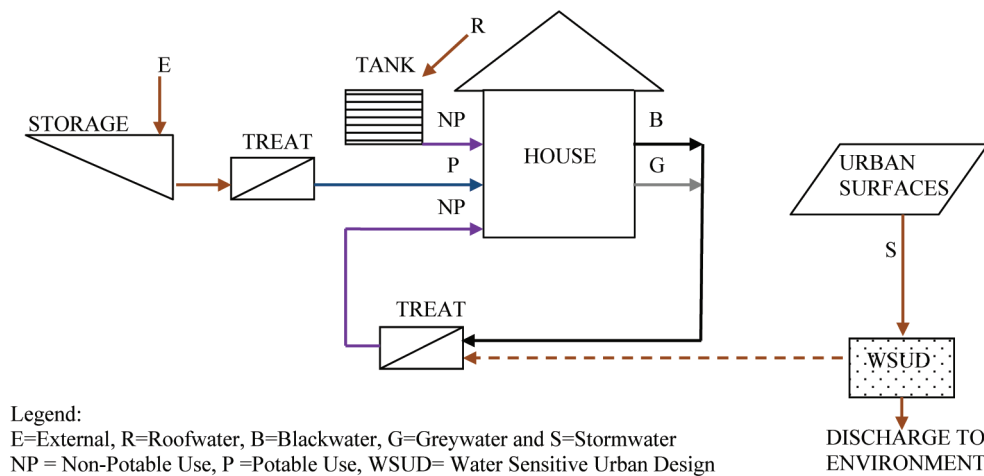

Fig. 1. Schematic diagram showing the generally accepted IWCP practice of multiple supply connections. Dashed line indicates that stormwater is not consistently integrated within the water supply system

lakes at Golden Gate Park, San Francisco [8]. Non-potable water connections were first made to high-rise buildings in 1961 in California for toilet flushing. Reclaimed water for garden irrigation and toilet flushing in a residential area was trialled in 1989 at Shoalhaven Heads forming the basis for Australia's first residential reuse guidelines in 1993 [9]. It is thus not unexpected that the approach of providing additional household water connections to service non-potable needs has expanded to connecting to the roofwater tank, in addition to dual reticulation. The trend of multiple household connections also is consistent with a view of providing water that is fit-for-purpose and a drinking water standard is excessive for the non-potable uses representing approx. 86% of the Australian household demand [6].

Potable and non-potable water have been kept separate as dual connections by a community reluctance to drink reclaimed water. Public support for the use of reclaimed water outside of the home is generally high (typically >90%), but gets lower as human contact with the treated water gets closer [10]. Based on a review of US studies dating from the 1970s, Hamilton and Greenfield [11] found that only 30–40% of people are either in favour, or would accept potable reuse of reclaimed water. The result of the 2006 referendum in Toowoomba is consistent with this community trend, as a 38% minority of residents were in favour of an indirect potable reuse scheme planned for this Australian city [12]. Australian national guidelines [13] relating to the reuse of water reclaimed from wastewater for drinking water purposes were recently released in 2008.

On the 'spent' water side, a single household sewer is generally provided to convey both greywater and black water. A dedicated sewer for greywater to allow reuse seems to be most applicable at this stage to residential apartments and Inkerman D'Lux at Melbourne is an

example. Utilisation of stormwater as a water resource is not widely practiced. Treatment of stormwater by water sensitive urban design (WSUD) techniques such as swales, bioretention devices and constructed wetlands are generally incorporated into residential subdivisions that adopt IWCP principles. In 50% of cases listed in Table 1, treated stormwater is released to the downstream environment and not reused.

### 3. Is providing multiple household supply connections the best approach?

Multiple supply connections to the household may not be the best approach available as 1) each supply line requires 'multiple barriers' against human health risk which increases duplication and complexity within the water supply system, and 2) risks are introduced on the 'supply' side of the water cycle, notably accidental or uninformed consumption of non-potable water and contamination of potable water by pipe cross connections. These aspects are further discussed below.

In Australia, the risks associated with reclaimed water are to be managed by techniques such as Hazard Analysis and Critical Control Points (HACCP). This is a systematic quality system in which potential risks to public health (and other water supply objectives) are identified and controlled at all points within the water supply, treatment and reticulation system. This introduces multiple barriers to limit adverse outcomes if there is a failure at a critical point within the system. These barriers may include advanced treatment processes in series, an environmental buffer (the practice of releasing highly treated water back to the source river, dam or aquifer prior to reuse) and non-structural measures such as community education programs and planning controls to prevent inappropriate land uses within water supply catchments.

The prevailing IWCP approach of multiple household connections appears at odds with the current risk management philosophy. Multiple barriers to prevent risk are required to be put in place for all water pathways to the consumer including potable water from external supplies, the non-potable dual reticulation system and/or water supplied from the roofwater tank. This potentially introduces replication of barriers across three separate supply systems, which adds complexity without necessarily providing an increased capacity to reduce risks.

Introducing non-potable water connections at each household also introduces a risk of this water being ingested and causing illness to residents. This could occur by direct consumption from the non-potable supply or by contamination of the potable supply from the lesser quality non-potable supply, as would be the case if undetected pipe cross connections are present. These risks are generally considered as being low, although water utilities require a high level of vigilance to prevent contamination events [14]. Techniques to manage or identify cross connections include adding colourants or anti-ingestants to non-potable water, incorporating early warning detection systems or backflow prevention devices in the network or applying water pressure differentials to prevent non-potable water ingress into the potable pipe system.

#### 4. An alternative IWCP approach

A schematic diagram of a suggested alternative IWCP approach to household water supply is shown as Fig. 2. It is based on a single potable water pathway to incorporate the perceived benefits of simplicity and reduced 'supply' side risks associated with the provision of non-potable water at a household connection. The potable water, be-

ing of a higher quality, will be also used for non-potable uses. Other main features are 1) the potential separation of blackwater to further reduce human health risk, 2) the integration of controlled stormwater flows into the water treatment and supply system and 3) the inclusion of a roofwater tank on the 'spent' side of the water cycle, rather than the current 'supply' preference. These aspects are discussed in more detail.

##### 4.1. A single potable water pathway

A single line of water supply is shown in Fig. 2 to avoid the replication of multiple barriers that is inherent within the currently preferred approach of connecting households with up to three different water supplies. Indirect potable reuse, involving the use of a storage buffer, is shown in Fig. 2 as it provides an extra barrier to control risk. A single potable water connection represents the bulk of conventional household water supplies in Australia, so retrofitting requirements to implement this approach would be generally minimal.

The concept of a single water supply connection utilising water reclaimed from sewage to service all household needs is, of course, not a new idea. Notable examples in practice are direct potable reuse schemes such as at Windhoek, Namibia and indirect reuse schemes using groundwater aquifers as environmental buffers (e.g. at El Paso, Texas). It does though require a 'leap of faith' by residential users to accept a potable water supply that has a component reclaimed from spent waters such as blackwater.

##### 4.2. Potential separation of blackwater

The separation of blackwater from the household

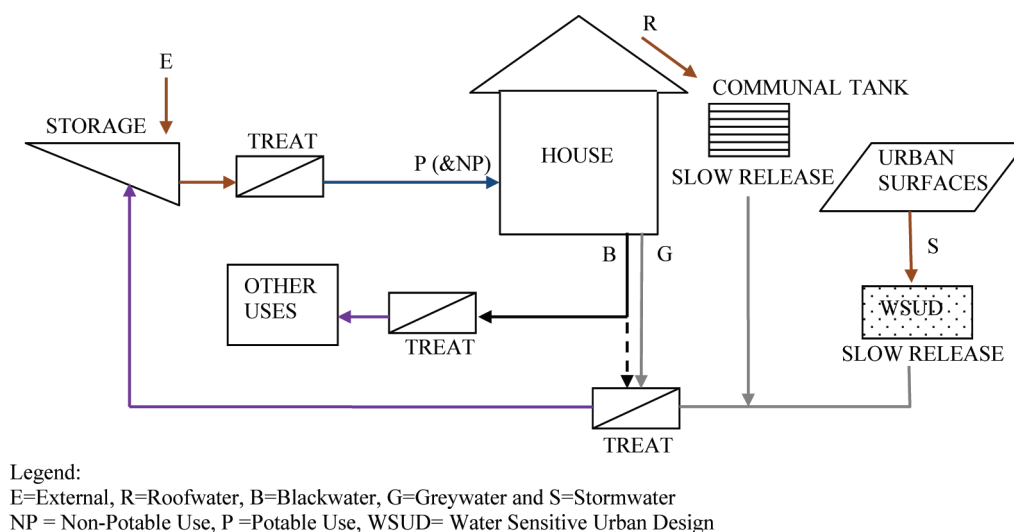

Fig. 2. Flow diagram showing suggested alternative IWCP practice of single supply connection, slow release of roofwater and stormwater and potential separation of spent waters (blackwater and greywater) for reuse.

spent waters made available for reuse would substantially reduce the 'yuck factor' associated with blackwater and this would significantly enhance community acceptance of spent water reuse. Blackwater also contains public health risk factors such as viruses and pathogens, and contaminants of concern such as excreted pharmaceuticals and hormones. Blackwater separation would thus represent another barrier within the multiple barrier framework to water reuse. Nutrients in the form of fertilisers can be recovered from blackwater, especially if allied with new technologies, such as membrane filtration, and smaller-scale decentralised systems [15].

The separation of blackwater with the intent of reusing greywater with stormwater as a potable resource is also not a new idea. Lu and Leung [16] considered shower and laundry water, combined with stormwater and treated, as a viable potable water resource for Hong Kong. Alternatives such as desalination of seawater were viewed to be either costly or, in the case of potable reuse of municipal sewage (containing blackwater) would not be publicly acceptable. A strategy of blackwater separation and the reuse of greywater and stormwater was also applied at the Inkerman D'Lux residential development located in Melbourne (Table 1). Scheumann et al. [17] have evaluated a range of technologies to treat greywater for reuse.

In Germany, Otterpohl et al. [18] describes a decentralised system (for >200 residents) that has separate collection and treatment of blackwater and greywater. Solids recovered from blackwater was planned to be incinerated, or processed further for biogas or compost, and the treated effluent used for toilet flushing. Membrane and reverse osmosis treatment of greywater produces potable water. A blackwater pilot system has been installed at the Technical University Hamburg Harburg.

An older precedent of blackwater separation is the Lienur system described by Bracken et al [19], quote: "In 1865, Prince Heinrich der Niederlande had asked T. Charles Lienur to remove the sewage from Castle Luxembourg without polluting the River Elz and without using wagons. Lienur's system consisted of two pipes. One carried roofwater, greywater and industrial water, while the other, which can be considered as the predecessor of modern vacuum sanitation systems, transported blackwater and wastewater from stables and slaughterhouses. The vacuum toilets required very little flushing water and the blackwater collected was used to produce "poudrette" (a dried natural fertiliser). At that time the industrial production of mineral fertiliser had not yet started (the first factories were built in 1870) and the price for fertiliser was high enough to allow the production and successful marketing of poudrette".

#### 4.3. Controlling stormwater so it can be better integrated

Integration of stormwater (runoff from urban surfaces other than roofs) into residential water supplies

has generally been an opportunistic part of Australian IWCP. As a potential water source, stormwater from urbanised areas can provide viable quantities of water for residential use due to the impervious nature of these catchments [20]. By its nature, stormwater is an intermittent resource governed by rainfall, thus comparatively large storages are needed to consistently yield a supply at a high reliability [21]. The impracticality of providing stormwater storage facilities within urban areas having limited available space is often given as a reason for not utilising stormwater.

However, there is one aspect that has the potential to promote the integration of stormwater within IWCP: the opportunity to utilise the stormwater detention systems that is an emerging requirement of urban development in Australia. Water sensitive urban design (WSUD) advocates the detention and treatment of stormwater within the urban landscape to minimise environmental impacts and many local authorities are setting WSUD principles as a requirement of urban development approval. These requirements are tending towards specifying the runoff capture and treatment associated with relatively frequent storms followed by a controlled release over a period of a few days. The WSUD Code for the Australian Capital Territory [22], for example, prescribes the detention of the 3-month average-recurrence-interval storm runoff with release over a 1–3 day period. For south east Queensland, it is planned that the initial 10–15 mm of storm runoff from new urban developments should be detained and released within 24 h [23].

It is becoming recognised that it is not necessary to capture and treat runoff for large, infrequent events in urban areas in order to achieve desired water quality and environmental outcomes in addition to producing reasonable yields of harvested stormwater. Walsh et al. [24] found that runoff frequency is a critical indicator of ecological degradation in urban waterways and advocated interception of impervious surface runoff during minor storms up to the magnitude that would have initiated surface runoff from the pre-developed catchment (typically 15–20 mm rainfall).

The WSUD approach of detaining, treating and slowly releasing stormwater is compatible with the harvesting of stormwater for reuse. The moderating effect of stormwater detention in reducing peaks and extending flow durations would significantly increase the temporal reliability of using stormwater as an urban water supply.

#### 4.4. A different role for roofwater tanks

The water supply benefits of roofwater have long been recognised in Australia, with 17% of households having a tank installed [25]. Some local authorities have mandated tank installation at individual lots within proposed residential developments, including a requirement to plumb into the house to supply non-potable uses. It is likely that

there will be a continuing preference for some residents to install a separate roofwater tank supply for their own use.

However, increased economies of scale can be achieved if roofwater is collected from multiple households and stored within a communal tank rather than smaller individual tanks. This is supported by the economic analysis by Mitchell et al. [26] who compared single connection roofwater tanks with larger multiple-connection systems utilizing both roofwater and stormwater. Life cycle costs fell rapidly as the scale increased from 1 to 100 connections and then levelled out after 1000 connections, which was a similar pattern found by Booker [27] for greywater reuse systems.

A communal tank takes the management of roofwater from household ownership (and varying levels of asset management) towards an integrated element of the urban stormwater system. In doing so, multiple benefits can be more effectively designed into a communal tank such as flood discharge reduction and, as shown in Fig. 2, the controlled release of stored water for further treatment and subsequent reuse. A properly designed and managed communal tank thus can provide a similar function as WSUD stormwater detention in moderating flows for the purpose of reuse.

Roofwater typically represents up to 33% of the storm runoff volume generated from residential areas [28] so roofwater interception significantly reduces the hydraulic loading to the stormwater drainage system. As a consequence, the performance of WSUD stormwater detention and treatment would also be enhanced by the installation of communal roofwater tanks.

## 5. Conclusions

A review of current Australian IWCP for residential development indicates a general acceptance of multiple household supply connections of potable and non-potable water. Separation of household spent waters (blackwater and greywater) and the use of stormwater as a potential urban water source are practices that are not generally adopted.

Multiple household connections require replication of multiple barriers to control human health risks and this increases system complexity. The recent advent of national guidelines [13] for using water reclaimed from spent waters to augment drinking water supplies is expected to be a driver towards a simpler, single potable water pathway to the household. This approach requires community acceptance of a potable water supply that has a component reclaimed from sources such as blackwater. Consumer confidence in using reclaimed water for drinking has yet to be fully tested in Australia.

An alternative IWCP approach based on a single supply connection is suggested, supplemented with the following features:

1. The potential separation of blackwater to provide an additional barrier to risk and to enhance community acceptance of spent water reuse.
2. Making use of WSUD requirements for new urban development which specify the controlled storage and slow release of stormwater, so that this water resource can be utilised more in IWCP.
3. Taking advantage of economies of scale by installation of communal tanks in preference to individual household tanks to store and slowly release roofwater for reuse. Communal tanks can be managed as part of a WSUD stormwater system to achieve better integration within the urban water supply.

Although a single supply is promoted, the suggested IWCP alternative is more complex than current approaches on the 'spent' side of the urban water cycle. Separation of blackwater and greywater, integrated with the controlled capture and release of stormwater and rainwater, will require a rethink of how (and in which combination) the drainage of various wastestreams can be accommodated to an acceptable level of risk and cost. Further research is needed to quantify the perceived benefits of the proposed IWCP alternative. These research activities should include detailed assessments of water balance, life cycle cost and risk at a case study level.

## References

- [1] P. Schneider, A. Davison, A. Langdon, G. Freeman, C. Essery, R. Beatty and P. Toop, Integrated water cycle planning for towns in New South Wales, Australia. *Water Sci. Technol.*, 47 (7–8) (2003) 87–94.
- [2] R. Clark, Optimum scale for urban water systems. Report 5: Water Sustainability in Urban Areas Series. Water Resources Group, South Australia Dept. of Environment and Natural Resources, 1997.
- [3] S.A. Fane, N.J. Ashbolt and S.B. White, Decentralised urban water reuse: The implications of system scale for cost and pathogen risk. *Water Sci. Technol.*, 46 (6–7) (2002) 281–288.
- [4] V.G. Mitchell, Applying integrated urban water management concepts: A review of Australian experience. *Environ. Manage.*, 37(5) (2006) 589–605.
- [5] M. Goddard, Urban greywater reuse at the D'Lux development. *Desalination*, 188 (2006) 135–140.
- [6] Australian National Water Commission. The cost-effectiveness of rainwater tanks in Australia. *Waterlines Occasional Paper No. 1*, Prepared by Marsden Jacobs Associates, March 2007.
- [7] H. Chapman, WRAMS, sustainable water recycling. *Desalination*, 188 (2006) 105–111.
- [8] T. Asano, Water from (waste)water — The dependable water resource. 11th Stockholm Water Symposium, Stockholm, Sweden, August 12–18, 2001.
- [9] J.M. Anderson, Integrating recycled water into urban water supply solutions. In: *Integrated Concepts in Water Recycling*, 2005.
- [10] T. Asano, Urban water recycling. *Water Sci. Technol.*, 51(8) (2005) 83–89.
- [11] G. Hamilton and P.F. Greenfield, Potable re-use of treated wastewater. *Australian Water and Wastewater Association, 14th Federal Convention Proc.*, 1 (1991) 497–506.
- [12] Australian National Water Commission. Using recycled water for drinking — an introduction. *Waterlines Occasional Paper*

- No. 2, Prepared by GHD, June 2007.
- [13] Environmental Protection and Heritage Council, National Health and Medical Research Council and Natural Resource Management Ministerial Council, Australian Guidelines for Water Recycling: Augmentation of Drinking Water Supplies, March 2008.
- [14] M.V. Storey, D. Deere, A. Davison, T. Tam and A.J. Lovell, Risk management and cross-connection detection of a dual reticulation system. *Water Reuse and Recycling*, S. Khan, R.M. Stuetz and J.M. Anderson, eds., UNSW Publishing, Sydney, Australia, 2007, pp. 459–466.
- [15] G. Tjandraatmadja, S. Burn, M. McLaughlin and T. Biswas, Rethinking urban water systems — revisiting concepts in wastewater collection and treatment to ensure infrastructure sustainability. *Water Sci. Technol.: Water Supply*, 5(2) (2005) 145–154.
- [16] W. Lu and A.Y.T. Leung, A preliminary study on potential of developing shower/laundry wastewater reclamation and reuse system. *Chemosphere*, 52 (2003) 1451–1459.
- [17] R. Scheumann, F. Masi, B. El Hamouri and M. Kraume, Greywater treatment as an option for effective wastewater management in small communities. *Desal. Water Treat.*, 4 (2009) 33–39.
- [18] R. Otterpohl, U. Braun and M. Oldenburg, Innovative technologies for decentralised water–wastewater and biowaste management in urban and peri-urban areas. *Water Sci. Technol.*, 48(11) (2003) 23–32.
- [19] P. Bracken, A. Wachtler, A.R. Panesar and J. Lange, The road not taken: how traditional excrete and greywater management may point the way to a sustainable future. *Water Sci. Technol.: Water Supply*, 7(1) (2007) 219–227.
- [20] V.G. Mitchell, T.A. McMahon and R.G. Mein, Components of the total water balance of an urban catchment. *Environ. Manage.*, 32 (2003) 735–746.
- [21] N. Apostolidis and N. Hutton, Integrated water management in brownfield sites — more opportunities than you think. *Desalination*, 188 (2006) 169–175.
- [22] Australian Capital Territory Planning and Land Authority. *Waterways — Water Sensitive Urban Design General Code*, 2007.
- [23] Queensland Department of Infrastructure. *Implementation Guideline No. 7, Water Sensitive Urban Design: Design Objectives for Urban Stormwater Management*. South East Queensland Regional Plan 2005–2026, 2008.
- [24] C.J. Walsh, T.D. Fletcher and A.R. Ladson, Stream restoration in urban catchments through redesigning storm water systems: looking to the catchment to save the stream. *J. North. Am. Benthol. Soc.*, 24 (2005) 690–705.
- [25] Australian Bureau of Statistics, *Water Account Australia 2004–05*, 2006.
- [26] V.G. Mitchell, A. Taylor, T.D. Fletcher and A. Deletic, *Stormwater reuse — potable water substitution for Melbourne*. ISWR Report No. 05/12, Monash University, Melbourne, Australia, 2005.
- [27] N. Booker, *Estimating the economies of scale of greywater reuse systems*. Program Report FE-99. CSIRO Molecular Science, Melbourne, Australia, 1999.
- [28] I. Brodie and F. Young, Case studies of applying spatial urban surface data in evaluating stormwater management issues, *J. Spatial Hydrol.* Fall 2007, 7(2) (2007) 06–0334.