

(19) World Intellectual Property Organization
International Bureau



(43) International Publication Date
26 August 2004 (26.08.2004)

PCT

(10) International Publication Number
WO 2004/072636 A1

(51) International Patent Classification⁷: **G01N 33/24**,
C22B 3/18

(AU). STEPANYANTS, Yury, A. [AU/AU]; 57B Ogilvy Street, Peakhurst, NSW 2210 (AU). RITCHIE, Alistair, Ian, Maxwell [GB/AU]; 26 Holborn Hill Road, Aldgate, SA 5154 (AU).

(21) International Application Number:
PCT/AU2004/000151

(74) Agent: **SPRUSON & FERGUSON**; G.P.O. Box 3898, Sydney, NSW 2001 (AU).

(22) International Filing Date: 11 February 2004 (11.02.2004)

(25) Filing Language: English

(81) Designated States (unless otherwise indicated, for every kind of national protection available): AE, AG, AL, AM, AT, AU, AZ, BA, BB, BG, BR, BW, BY, BZ, CA, CH, CN, CO, CR, CU, CZ, DE, DK, DM, DZ, EC, EE, EG, ES, FI, GB, GD, GE, GH, GM, HR, HU, ID, IL, IN, IS, JP, KE, KG, KP, KR, KZ, LC, LK, LR, LS, LT, LU, LV, MA, MD, MG, MK, MN, MW, MX, MZ, NA, NI, NO, NZ, OM, PG, PH, PL, PT, RO, RU, SC, SD, SE, SG, SK, SL, SY, TJ, TM, TN, TR, TT, TZ, UA, UG, US, UZ, VC, VN, YU, ZA, ZM, ZW.

(26) Publication Language: English

(30) Priority Data:
2003900604 11 February 2003 (11.02.2003) AU

(71) Applicant (for all designated States except US): **AUSTRALIAN NUCLEAR SCIENCE & TECHNOLOGY ORGANISATION** [AU/AU]; New Illawarra Road, Lucas Heights, NSW 2234 (AU).

(84) Designated States (unless otherwise indicated, for every kind of regional protection available): ARIPO (BW, GH, GM, KE, LS, MW, MZ, SD, SL, SZ, TZ, UG, ZM, ZW), Eurasian (AM, AZ, BY, KG, KZ, MD, RU, TJ, TM), European (AT, BE, BG, CH, CY, CZ, DE, DK, EE, ES, FI, FR,

(72) Inventors; and

(75) Inventors/Applicants (for US only): **BENNETT, John, William** [AU/AU]; 6/33 Burke Road, Cronulla, NSW 2230

[Continued on next page]

(54) Title: MEASURING RATE OF CHANGE OF OXYGEN CONCENTRATION AND INTRINSIC OXIDATION RATE IN A PILE OF MATERIAL

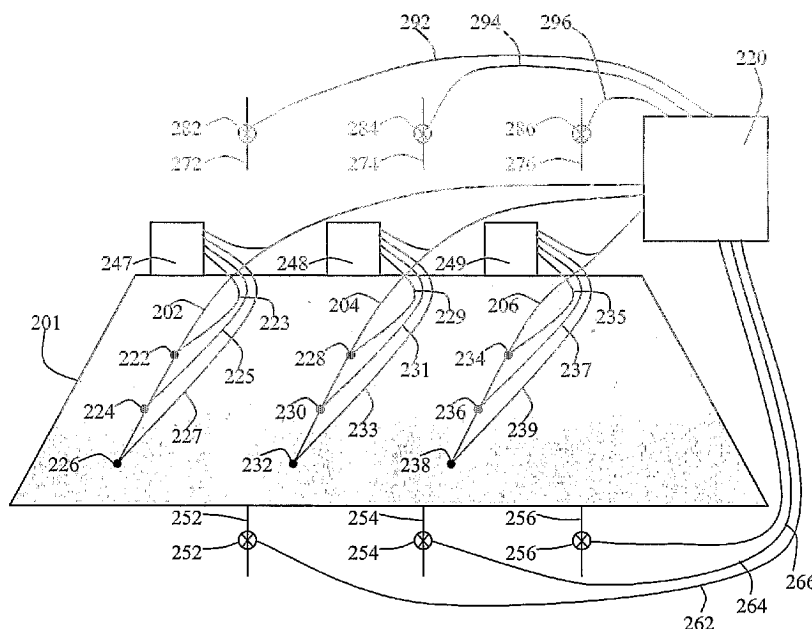

(57) Abstract: The rate of change of gaseous oxygen concentration, in a pile of material such as a bioleach pile or a waste rock pile (201), is determined at one or more locations (222, 224, 226, 228, 230, 232, 234, 236, 238) by adding oxygen gas to a region of the pile; and measuring the oxygen concentrations at the locations as they change over time. A spatial distribution of intrinsic oxidation rates may then be calculated, and the results used to control the operation of the pile via, for example, selective aeration (252, 254, 256) or irrigation (282, 284, 286).

WO 2004/072636 A1



GB, GR, HU, IE, IT, LU, MC, NL, PT, RO, SE, SI, SK,
TR), OAPI (BF, BJ, CF, CG, CI, CM, GA, GN, GQ, GW,
ML, MR, NE, SN, TD, TG).

For two-letter codes and other abbreviations, refer to the "Guidance Notes on Codes and Abbreviations" appearing at the beginning of each regular issue of the PCT Gazette.

Published:

— *with international search report*

MEASURING RATE OF CHANGE OF OXYGEN CONCENTRATION AND INTRINSIC OXIDATION RATE IN A PILE OF MATERIAL

Technical Field

5 The present invention relates to methods and systems for measuring rates of change in oxygen concentration and for measuring intrinsic oxidation rates in a pile of material. In one form, it relates to a method for measuring *in situ* the rate of change in oxygen concentration and intrinsic oxidation rate in the pile.

Background of the Invention

10 The use of biooxidation and bioleach piles in which the operating conditions of the piles are closely controlled is a recent innovation in the mining industry. The piles are typically used to break down sulfidic minerals in refractory gold ores so as to improve the amount of gold extracted in subsequent processing, or to release metals into lixivants through the oxidation of the sulfidic minerals. It is important in the operation of these
15 piles to optimise the oxidation rates in the pile in order to optimise the yield of metals and the rate of conversion of metal substances in the pile to metal substances from which the metal is recoverable.

 Acid mine drainage (AMD) resulting from the oxidation of sulfidic waste sediments in waste rock piles generated by the mining industry, is a major environmental
20 problem. The problems with waste sediment arise when atmospheric oxygen gains access to sediment layers containing sulfides. The oxidation of sulfides produces a high groundwater sulfate concentration, a low pH and traces of metals such as nickel, copper, cobalt, zinc, lead and mercury. The pollutant concentrations in drainage depend mainly on the rate of pollutant generation in the waste sediments. There is a need for technology that
25 can measure *in situ* a rate of oxidation of the materials in a waste rock pile in a short period of time, so that decisions regarding classification and management of the pile can be made in a timely manner.

 The conventional technology relating to the use of biooxidation and bioleach piles in the processing of minerals relies primarily on indicators such as iron concentration and
30 microbial population in runoff water, which are external to the pile, in order to monitor progress of oxidation of materials within the pile and to determine optimal operational . A disadvantage of the use of such external indicators is that there is a significant time lag between changes in the oxidation processes in the pile and changes in the external

indicators. A further disadvantage of the conventional technology is that the use of external indicators can only provide a measure of overall pile performance but can not provide information about the spatial distribution of oxidation rates within the pile. There is, therefore, a need for technology that can provide information on the spatial distribution of oxidation rates within a pile. There is a further need for technology that can provide that information rapidly and repeatedly, so that changes to the operating conditions of the pile can be made in response to changes in the oxidation processes occurring in the pile in order to improve the operating efficiency of the pile.

Conventional technology relating to both biooxidation/bioleach piles and waste rock piles may alternatively or additionally rely on the determination of the oxidation rate of materials based on the use of laboratory instruments to estimate oxidation of the oxidisable material in the pile, using small samples from a pile. A disadvantage of these laboratory determinations, however, is that they cannot provide real-time information on conditions within a pile at a particular location and time. A further disadvantage of laboratory measurement of oxidation rates is that sampling from the pile in order to conduct laboratory-based analysis may interfere with the operation of the pile and may also affect the sample so taken in a manner that alters its oxidation rate.

A technical paper by Elberling *et al* (Nordic Hydrology, 24, 1993, 323-338) describes a method for estimating relative oxidation rates of materials in a waste mineral pile by measuring oxygen concentration within the pile as a function of depth. That method however does not use deliberately oxygenation of the measurement site, but instead relies on diffusion of oxygen from outside the pile. In doing so, the authors measure an oxygen gradient within the oxygen diffusion zone (less than 1 metre) near the surface of the pile of material, and derive the relative oxidizability of materials in the pile from the oxygen flux associated with that gradient. Since the method relies on the oxygen gradient near the surface of the pile, it is not capable of providing information on oxidation rates deep within the pile. A further disadvantage is that it can not provide an accurate spatial distribution of oxidation rates within a pile. Still another disadvantage is that it can provide only relative rates of oxidation, based on the determined oxygen flux. These may be useful in comparing different waste piles, but can not be used effectively to predict rates of production of pollutants. Yet another disadvantage is that this method is only applicable to waste mineral piles, and not to biooxidation and bioleach piles, since

the forced aeration that is practised in biooxidation and bioleach piles would disrupt the oxygen gradient that is central to the method.

Object of the Invention

It is an object of the present invention to overcome or substantially ameliorate at least one of the above disadvantages. Another object is to address some or all of the
5
aforementioned needs.

Summary of the Invention

In a first aspect of the invention there is provided a method of determining a rate of change in a gaseous oxygen concentration within a pile of material, said pile of material
10
comprising both solid phase and gas phase and optionally liquid phase, comprising the steps of:

- (i) altering the gaseous oxygen concentration in at least a part of the pile of material;
- (ii) measuring the gaseous oxygen concentration in at least one location
15
within that part of the pile of material altered by the gas containing oxygen;
- (iii) repeating the measuring a sufficient number of times at the at least one location to enable determination of a rate of change in the gaseous oxygen concentration, wherein the altering of step (i) is ceased at least
20
prior to the repeating; and
- (iv) determining the rate of change in the gaseous oxygen concentration in the at least one location.

The altering may comprise passing a gas containing oxygen through the at least a part of the pile. The method may additionally comprise the step of determining an
25
intrinsic oxidation rate (IOR) at the at least one location in the pile. The equation:

$$S_o^a = -\frac{\varepsilon \rho^{in}(0)(1 - \Omega_o)}{[1 - \omega_o(t)]^2} \frac{\partial \omega_o}{\partial t}$$

may be used to calculate an approximate value of the IOR of oxidisable material in the pile, wherein:

- S_o^a is an approximate value of the IOR;
- 30 ε is the volume fraction of the gas phase in the pile of oxidisable material; and

$\rho^{in}(0)$ is the intrinsic gas density of the gas at the location in the pile at which the IOR is determined, immediately after the altering of the gaseous oxygen concentration therein.

The concentration of oxygen in the gas containing oxygen may be sufficient to make the oxygen concentration in the at least one location approximately equal to the concentration of oxygen in air. The method may comprise the steps of aerating at least a part of the pile of material and of ceasing the aeration before the step of measuring the gaseous oxygen concentration. The step of measuring may comprise the steps of :

- (a) transferring a sample of gas from the region surrounding the probe to a location external to the pile;
- (b) passing the sample of gas to a device capable of measuring gaseous oxygen concentration; and
- (c) using the device to measure a gaseous oxygen concentration of the sample of gas.

The method may additionally comprise recording the time at which each of the steps of measuring is performed.

In an embodiment, the step of altering comprises forming a cavity in the pile of material such that the oxygen content of the gas phase in said cavity and in the surrounding region is substantially the same as the oxygen concentration in the ambient atmosphere outside the pile of material. A probe for measuring oxygen may be inserted into the cavity.

In another embodiment, the rate of change of oxygen concentration is measured a plurality of times, and the change with time in at least one of the IOR and the rate of change of oxygen concentration is used to estimate at least one of:

- (i) a change in the rate of conversion of metal substances in the pile to metal substances from which the metal is recoverable, as a function of time,
- (ii) a change in the rate of production of pollutants in the pile as a function of time, and
- (iii) an effective lifetime of the pile.

In a second aspect of the invention there is provided a method of determining a spatial distribution of rates of change of gaseous oxygen concentration within a pile of

material, said pile of material comprising both solid phase and gas phase and optionally liquid phase, comprising the steps of:

- (i) locating a plurality of probes in the pile;
- (ii) altering the gaseous oxygen concentration surrounding at least two of the probes;
- (iii) measuring an oxygen concentration in the gas surrounding the at least two of the probes in the pile;
- (iv) determining a rate of change in oxygen concentration of the gas surrounding the at least two of the probes in the pile wherein the determining comprises measuring the oxygen concentration in the gas surrounding at least two of the probes after the altering of step (ii) has been stopped; and
- (v) determining a spatial distribution of rates of change in gaseous oxygen concentration in the pile.

The altering may comprise passing a gas containing oxygen through the locations of the at least two of the probes. The method may additionally comprise the step of determining a spatial distribution of IORs within the pile.

In a third aspect of the invention there is provided a method of controlling the operating conditions of a pile of material, said pile of material comprising both solid phase and gas phase and optionally liquid phase, comprising:

- (i) determining information selected from the group consisting of an IOR of oxidisable material in the pile and a spatial distribution of IORs of oxidisable material in the pile; and
- (ii) adjusting at least one operating condition of the pile.

The step of adjusting may comprise a process selected from the group consisting of aerating at least one portion of the pile and contacting at least one portion of the pile of material with a liquid selected from the group consisting of water and an aqueous liquid.

In a fourth aspect of the invention there is provided a method for constructing, and controlling the operating conditions of, a pile of material, said pile of material comprising both solid phase and gas phase and optionally liquid phase, comprising:

- (i) determining at least one property of the material;

- (ii) using the at least one property in a model to determine a value of at least one parameter of construction of the pile of material;
- (iii) constructing the pile using the value of the at least one parameter of construction;
- 5 (iv) determining information selected from the group consisting of an IOR of oxidisable material in the pile and a spatial distribution of IORs of oxidisable material in the pile; and
- (v) adjusting the operating conditions of the pile.

The at least one property of the material may be selected from the group consisting
10 of porosity, gas permeability, sulfur content, IOR, and a combination of these. The model may be a computer model based on a deterministic formulation of multiphase flow through porous media. The step of adjusting may include a process selected from the group consisting of aerating the pile and contacting the pile of material with a liquid selected from the group consisting of water and an aqueous liquid.

15

In a fifth aspect of the invention there is provided a system for determining a rate of change in a gaseous oxygen concentration within of a pile of material, said pile of material comprising both solid phase and gas phase and optionally liquid phase, said system comprising:

- 20 (i) means for altering the gaseous oxygen concentration in at least a part of a pile of material;
- (ii) means for measuring the gaseous oxygen concentration within the pile of material;
- (iii) means for repeating the measuring of the gaseous oxygen concentration
25 within the pile of material;
- (iv) means for determining the rate of change in the gaseous oxygen concentration.

The means for altering may comprise for example an aerator such as a gas vent or a gas outlet, and may comprise means for passing a gas containing oxygen through the at
30 least part of the pile, for example an aerator such as a gas vent or a gas outlet, and means for stopping the passing, for example a valve. The valve is commonly fitted to the means for passing a gas. The system may further comprise:

- (a) means for determining the time at which the measuring occurred; and
- (b) means for determining an intrinsic oxidation rate at a location within the pile.

The means for determining the time may be for example a data logger or a timing device. The means for determining an intrinsic oxidation rate may be for example a computer or other calculating device.

In a sixth aspect of the invention there is provided a system for determining a spatial distribution of rates of change in gaseous oxygen concentration within a pile of material, said pile of material comprising both solid phase and gas phase and optionally liquid phase, said system comprising:

- (i) a plurality of probes capable of being located in the pile;
- (ii) means for altering the gaseous oxygen concentration surrounding at least two of the probes;
- (iii) means for measuring the gaseous oxygen concentration in the gas surrounding the at least two of the probes in the pile;
- (iv) means for determining the rate of change in gaseous oxygen concentration of the gas surrounding the at least two of the probes in the pile; and
- (v) means for determining a spatial distribution of rates of change in gaseous oxygen concentration in the pile.

The means for altering may comprise for example at least one aerator, such as a gas vent or a gas outlet, and may comprise means for passing a gas containing oxygen through the location of the at least two of the probes for example at least aerator, such as a gas vent or a gas outlet, and means for stopping the altering, for example at least one valve. The at least one valve is commonly fitted to the means for passing a gas. The system may additionally comprise means for determining a spatial distribution of IORs within the pile for example a computer or other calculating device.

In one embodiment of the sixth aspect of the invention, more than one probe is connected to a particular means for measuring and there is additionally means to selectively direct gas from a probe connected thereto to the particular means for measuring at any particular time. The means to selectively direct gas may comprise one or more valves, and may also comprise a controller for controlling the valve(s).

In a seventh aspect of the invention there is provided a system for controlling the operating conditions of a pile of material, said pile of material comprising both solid phase and gas phase and optionally liquid phase, comprising:

- (i) means for determining information selected from an IOR of oxidisable material in the pile and a spatial distribution of IORs in the pile; and
- (ii) means for adjusting at least one operating condition of the pile.

The means for determining information may conveniently comprise for example a system according to the present invention for determining a rate of change of gaseous oxygen concentration. The means for adjusting may comprise means selected from the group consisting of means for aerating the pile, for example an aerator, and means for contacting the pile of material with a liquid selected from the group consisting of water and an aqueous liquid, for example an irrigator. The system may comprise a computer, and the means for determining may comprise a computer. The means for adjusting may be capable of adjusting the operating conditions selectively in different portions of the pile.

Brief Description of the Drawings

Preferred forms of the present invention will now be described with reference to the accompanying drawings wherein:

Figure 1a is a diagrammatic representation of a waste rock pile showing positions of a plurality of holes in each of which are located probes for measuring oxygen concentration, and optionally also other parameters, in accordance with the method of the present invention;

Figure 1b is a diagrammatic representation of a biooxidation/bioleach pile, showing positions of a plurality of strings of probes for measuring oxygen concentration, and optionally also other parameters, means for supplying air and water to the pile and a computer for controlling the above components;

Figure 1c is a diagrammatic representation of a biooxidation/bioleach pile that has been constructed in two stages, showing two sets of strings of probes for measuring oxygen concentration, and optionally also other parameters, means for supplying air to the pile and a computer for controlling the above components;

Figure 2 is a diagrammatic representation of the drilling of a hole in a waste rock pile using a drill which injects air into the heap, for example a rotary percussion air blast, for providing holes for the insertion of probes in the pile and for modifying the concentration of oxygen in a region surrounding the hole, using the method in accordance with the second embodiment of the invention;

Figure 3 is a diagrammatic representation of a hole in a waste rock pile, showing two groups of probes at different depths capable of measuring oxygen concentration, temperature and another parameter, the connection of the oxygen probe tubes to an oxygen sensor, the connections of the probes to a computer and the backfill used to seal the hole;

Figure 4a is a graph representing the change in oxygen concentration over time within two different uniformly aerated biooxidation/bioleach piles, which have different rates of oxygen consumption wherein the results are obtained from a plurality of probes within each pile;

Figure 4b is a graph representing the change in oxygen concentration over time as a function of depth for 3 different sizes of the aeration zone in a waste rock pile represented in Figure 1a;

Figure 5a is a graph representing the change in the relative deviation of the approximate IOR from its more precise value (as determined by Equation 1), over time, at different points within a biooxidation/bioleach pile corresponding to the oxygen concentration curves for Pile 1 in Figure 4a;

Figure 5b is a graph representing the change in the relative deviation of the approximate IOR from its more precise value (as determined by Equation 1), over time, as a function of depth, for 3 different sizes of the aeration zone, corresponding to the oxygen concentration curves in Figure 4b; and

Figure 6 shows the dependence of the IOR (as a proportion of the maximum IOR) as a function of the oxygen concentration (as a proportion of atmospheric oxygen concentration).

Detailed Description of the Invention

The IOR(s) and/or the rate(s) of change of oxygen concentration may be used to estimate one or more of the rate of conversion of metal substances in the pile to at least one metal substance from which the metal is recoverable, the amount of recoverable metal in the pile and the rate of production of pollutants in the pile. The metal substances may be metal compounds, metal salts, metal complexes, organometallic compounds, metals or other metal substances. The IOR(s) and/or the rate(s) of change of oxygen

concentration may be used to estimate one or more of the rate of conversion of metal substances in the pile to at least one metal substance from which the metal is extractable.

The part of the pile in which gaseous oxygen concentration is altered in the method of determining a rate of change of oxygen concentration may comprise a contiguous part of the pile or it may comprise a collection of unconnected portions or it may comprise the
5 entire pile.

The gas containing oxygen may be air, oxygen or a mixture of oxygen and one or more other gases, the other gases being for example nitrogen, helium, carbon dioxide etc. The concentration of oxygen in the gas containing oxygen is greater than the oxygen
10 concentration in gas in the pile prior to the altering, at the location(s) where the measuring is performed. The concentration of oxygen in the gas containing oxygen may be greater than about 5% on a weight, volume or mole basis, or greater than about 10, 15, 20, 30, 50, 50, 60, 60, 80 or 90%, or between about 100% and about 5%, or between about 50% and about 10% or between about 30% and about 15%, and may be about 5, 10, 15, 20, 25, 30,
15 40, 50, 60, 70, 80, 90 or 100% on a weight, volume or mole basis. Preferably the gas is air, and preferably the altering of step (i) is sufficient to make the oxygen concentration in the at least one location where measurements are made approximately equal to the concentration of oxygen in air.

The step of measuring gaseous oxygen concentration in the method of determining
20 a rate of change of oxygen concentration may be performed at least twice, and may be performed at least 3, 4, 5, 10, 15, 20, 30, 40 or 50 times, or between 2 and 50 times, or between 3 and 40 or between 4 and 30 or between 5 and 20 or between 10 and 15 times, and may be performed 2, 3, 4, 5, 10, 15, 20, 25, 30, 40 or 50 times. Alternatively the measuring may be performed continuously over a period of time.

25 Optionally the step of measuring gaseous oxygen concentration may be repeated one or more times prior to cessation of the altering of step (i).

The IOR(s) is/are are function of oxidisable material in the pile which causes the change in the gaseous oxygen concentration. The IOR(s) is/are determined at the location(s) where steps (ii) and (iii) are carried out in the pile. The IOR $S_O(\omega_o, \omega_s, T)$ is
30 frequently described by the Monod formula:

$$S_o(\omega_o, \omega_s, T) = S_{\max} A(T) \left(\frac{\omega_o}{\Omega_o} \frac{\sigma_1 + 1}{\sigma_1 + \omega_o/\Omega_o} \right) \left(\frac{\omega_s}{\Omega_s} \frac{\sigma_2 + 1}{\sigma_2 + \omega_s/\Omega_s} \right) \quad (1)$$

Here S_{\max} is the maximum value of the IOR at atmosphere oxygen concentration; $\sigma_1 = \sigma_2 = 0.05$ are empirical constants; ω_o and ω_s are the oxygen and sulfur mass fractions respectively at a given instant of time and at a given position in the pile of material; Ω_o is an initial value of the oxygen mass fraction in the gas phase, which equals the oxygen mass fraction in the atmosphere and has an approximate value of 0.231 in the case that atmospheric air is used to alter the oxygen concentration within the pile; and Ω_s is the initial mass fraction of sulfur. The factor $A(T)$ is a smooth function of temperature equalling unity at relatively low temperatures, $T < 40^\circ\text{C}$.

Examples of piles of oxidisable materials include biooxidation piles, bioleach piles, waste rock dumps and the like. Whereas the present invention is intended primarily for use in the mining industry, it may also be used in other industries, for example food and agriculture, or other industries in which piles of oxidisable materials occur.

The gaseous oxygen concentration may be expressed as any one of the following: a percentage based on weight, a percentage based on volume, mole fraction, mass fraction, weight fraction, volume fraction or any other commonly used means to express such a concentration. Conveniently the gaseous oxygen concentration may be measured using a probe, or a plurality of probes, which may be inserted into the pile of material.

The rate of change in gaseous oxygen concentration may be conveniently be determined by any one of the following means:

- (i) subtracting one value of gaseous oxygen concentration from another value of gaseous oxygen concentration and dividing the result by the time difference between the measurement of the two values;
- (ii) determining a slope of a line through some or all of the points representing the measured values of gaseous oxygen concentration on a graph of oxygen concentration against time;
- (iii) determining a slope of a tangent to a curve representing the measured values of gaseous oxygen concentration on a graph of oxygen concentration against time;

- (iv) any other convenient means to determine the rate of change of gaseous oxygen concentration.

An equation may be used to calculate the IOR in the region adjacent to the probe. The following equation may be used to calculate an approximate value of the IOR of oxidisable material in the pile:

$$S_o^a = -\frac{\varepsilon \rho^{in}(0)(1 - \Omega_o) \partial \omega_o}{[1 - \omega_o(t)]^2 \partial t} \tag{2}$$

wherein:

- S_o^a is an approximate value of the IOR;
- ε is the volume fraction of the gas phase in the pile of oxidisable material; and
- $\rho^{in}(0)$ is the intrinsic gas density of the gas at the location in the pile at which the IOR is determined, immediately after the altering of the gaseous oxygen concentration therein.

Equation 2 may be derived from mass balance equations for the total gas phase (Equation 3a) and for the oxygen density (Equation 3b):

$$\frac{\partial \rho_g}{\partial t} + \text{div}(\rho_g \mathbf{v}^g) = -S_o(\omega_o, \omega_s, T) \tag{3a}$$

$$\frac{\partial(\rho_g \omega_o)}{\partial t} + \text{div}[\rho_g \omega_o \mathbf{v}^g - D_o \nabla(\rho_g \omega_o)] = -S_o(\omega_o, \omega_s, T), \tag{3b}$$

where:

- \mathbf{v}^g is an intrinsic pore gas velocity; and
 - ρ_g is a pore gas bulk density; and
 - D_o is the effective diffusion coefficient of oxygen in the porous medium;
- by assuming that diffusion of oxygen within the pile is insignificant. This assumption may be valid in the period shortly after the gas in the at least part of the pile has been altered.

In an example of the method, which is applicable to biooxidation and bioleach piles, the rate of change of oxygen concentration, and optionally also the IOR, is measured a

plurality of times. The change with time in one or both of the IOR and the rate of change of oxygen concentration may be used to estimate one or more of:

- (a) the change in the rate of conversion of metal substances in the pile to metal substances from which the metal is recoverable, as a function of time,
- 5 (b) the change in the rate of production of pollutants in the pile as a function of time, and
- (c) the effective lifetime of the pile.

The measurements may be made sufficiently frequently and at sufficient time intervals to allow the estimates of (a), (b) and/or (c) to be made, but preferably not so frequently as to interfere unduly with the operation of the pile. The time interval between
10 measurements may be for example between about 4 and 40 days, or between 5 and 35 days or between 6 and 30 days or between 7 and 25 days or between 8 and 20 days or between 10 and 15 days, and may be about 4, 5, 6, 7, 8, 9, 10, 15, 20, 25, 30, 35 or 40 days. The effective lifetime of a pile may commonly be about 6 months for a biooxidation pile. Thus measurements may be made between 2 and 40 times, or between
15 3 and 35 or between 4 and 30 or between 5 and 25 or between 5 and 20 times, and may be made about 2, 3, 4, 5, 6, 7, 8, 9, 10, 15, 20, 25, 30, 35 or 40 times. An estimate of the lifetime may be achieved by extrapolating one or more of the IOR and the rate of change of oxygen concentration, and estimating therefrom the time at which a particular percentage of the initial sulfur will have been oxidised (for example 90% or 95%) or a
20 range (for example 85-95% or 90-100%).

(i) The invention also provides a method of determining a spatial distribution of rates of change in gaseous oxygen concentration within a pile of material. Insertion of a plurality of probes into the pile may be accomplished by either locating the probes during building of the pile of material, or inserting probes into holes cut in the pile. The plurality
25 of probes may be arranged in a predetermined array. The distribution of probes is commonly dictated by convenience and cost.

In the case that probes are inserted into holes drilled into the pile, there may be a plurality of probes inserted into each of the holes at different depths in order to provide information about the spatial distribution of conditions within the pile. There may be a
30 plurality of such holes, each of which would commonly be no closer than 0.5 metre to another such hole. Preferably, for example, in a pile of 100 metres by 100 metres there

may be about 9801 such holes, representing about 1 hole every 1 metre, or there may be about 361 such holes, representing about 1 hole every 5 metres, or there may be about 16 holes, representing about 1 hole every 20 metres or there may be a different number of holes (which may be between 9801 and 16 or greater than 9801 or less than 16). This
5 would commonly be the case when the pile was a mineral waste dump pile.

In the case that probes are inserted into the pile during construction of the pile, which is most commonly the case when the pile is a biooxidation or bioleach pile, the probes may be inserted into the pile in connected groups (“strings”) which may be inserted at an angle to the vertical, the angle being dictated by convenience in the
10 construction of the pile. Preferably a plurality of the strings is inserted into a pile, each of which would commonly be no closer than 0.5 metre to another such string. Preferably, for example, in a pile of 100 metres by 100 metres there may be about 9801 such strings, representing about 1 string every 1 metre, or there may be about 361 such strings, representing about 1 string every 5 metres, or there may be about 16 strings, representing
15 about 1 string every 20 metres or there may be a different number of strings (which may be between 9801 and 16 or greater than 9801 or less than 16).

It will be understood that the pile may be constructed in different stages. Thus initially, a first part of the pile may be constructed, with a first set of strings being inserted as the first part of the pile is constructed. Subsequently a second part of the pile may be
20 constructed, with a second set of strings being inserted as the second part of the pile is constructed. The second part of the pile may be on top of the first part, or it may be beside the first part or it may be in some other location relative to the first part. It will be further understood that the pile may have more than two parts, and may have for example 1, 2, 3, 4, 5, 6, 7, 8, 9, 10 or more than 10 parts, each of which may be constructed with a
25 separate set of strings being inserted as it is constructed, and each being, independently, on top of, beside, or in some other location relative to, any other stage of the pile.

The probe, or, in the event that a plurality of probes is used, at least one of the probes, may be capable of measuring the concentration of oxygen in the gas phase in the region adjacent to the probe. Advantageously, the probe(s) may also be capable of
30 measuring the temperature of the pile of material in the region surrounding the probe. More advantageously, the probe(s) may also be capable of measuring one or more other parameters of interest in managing the pile of material, for example gas permeability and

gas pressure. Alternatively, separate probes may be provided to determine temperature and/or the one or more other parameters. Preferably the probe capable of measuring temperature is a thermocouple or a thermistor. The probe for measuring another parameter of interest may be a manometer.

5 The period of time over which the measurements are made may be any period from about 1 hour to several days (eg 1 to 5 days or 1 to 3 days or 1 day) or even weeks. The time period is preferably less than about 15 hours or less than 12 hours or less than 10 hours. The time period may be in the range of 1 to 15 hours, 1 to 14 hours, 1 to 13 hours, 1 to 12 hours or 1 to 10 hours. The time period may be about 1, 2, 3, 4, 5, 6, 7, 8, 9, 10,
10 11, 12, 13, 14, 15 or 16 hours. More preferably, the measurements are made over a period in the range of from about 1 to about 5 hours. In the case of bioleach and biooxidation piles, this may help to ensure that the determination of the IOR causes as little as possible disruption to the operation of the piles, and may enable calculation of the IOR to be made sufficiently rapidly so as to permit effective control of the operational conditions of the
15 pile of material. In the case of waste mineral dump piles, this may enable rapid classification of the dumps based on the measured IOR or distribution of the IORs.

 Preferably, the measurement of oxygen concentration in the region adjacent to the probe and the subsequent calculation of the IOR do not interfere significantly with the oxidation of the pile of material.

20 The method may include a step in which the calculated IOR is used to make decisions concerning operation of the pile. Optionally, data relating to other parameters of the pile, for example temperature, are also used in making said decisions. Preferably, in the case that the pile is a biooxidation or a bioleach pile, the decisions relate to adjusting the operating conditions of the pile of material. More preferably the decisions relate to
25 improving the operating conditions of the pile of material.

 When IOR, or the spatial distribution thereof, is used in a method for controlling the operating conditions of a pile of material, other parameters may be measured in order to determine how to adjust the operating conditions of the pile. Commonly, one of the other parameters is temperature. The step of adjusting may include aerating the pile and/or
30 contacting the pile of material with water or aqueous liquid. The pile may be aerated and/or contacted with water or an aqueous liquid at a rate sufficient to improve the oxidation rate of the pile of material. The step of adjusting may also include using other

methods to affect the oxidation rate of the pile of material. Preferably aerating and/or contacting with water or aqueous containing liquid are at a rate sufficient to optimise the oxidation rate of the pile of material. The oxidation rate may be a rate of biooxidation of sulfur-containing materials in the pile.

5 Alternatively or additionally, the calculated IOR or a distribution thereof, optionally together with other data gathered from the same or a different probe(s), may be used for computer modelling or simulation of the operation of the pile of material, in order to determine the effect of specific conditions on the operation of the pile of material.

 In an example, the method includes the step of aerating the pile of material and
10 then ceasing the aeration before the measurement of oxygen concentration is made or before the first of two or more measurements of oxygen concentration is made, in order to provide a gaseous oxygen concentration in the pile of material that is approximately homogeneous and is higher than the gaseous oxygen concentration before the aerating. Alternatively, the oxygen concentration within the pile may be altered using oxygen or a
15 mixture of gases, said mixture containing oxygen. The oxygen concentration in the mixture of gases is greater than the oxygen concentration in the gas in the pile prior to the altering, at the location(s) where the measurements are made. Advantageously, the steps of aerating the pile or altering the oxygen concentration within the pile, and determining the IOR, may be repeated more than once. More advantageously the said steps may be
20 repeated without moving the probe(s).

 In another example, the or each probe is inserted into a cavity in the pile of material that has been aerated such that the oxygen content of the gas phase in the cavity and in the surrounding region is substantially the same as the oxygen concentration in the ambient
25 atmosphere outside the pile of material. The region preferably has a radius of greater than 3 metres, more preferably greater than 4 metres and still more preferably greater than 5 metres. This embodiment may provide an initial level of oxygen in the region surrounding the probe that is similar to the level in the atmosphere outside the pile of material. Alternatively, the oxygen concentration in the cavity and the region surrounding the
30 cavity may be altered before the measurement of oxygen concentration, using oxygen or a mixture of gases, said mixture containing oxygen. Preferably, the cavity into which the probe is inserted is formed using a drill that passes air, oxygen or a mixture of gases, said mixture containing oxygen, into the cavity as the drilling progresses. The cavity may be a

hole that has been drilled in the pile. The cavity or hole may be sealed or closed after the probe(s) is (are) appropriately located therein. The sealing or closing is conveniently achieved by backfilling the cavity or hole.

Preferably the time elapsed after aeration of the pile of material and the distance of the probe from the surface of the pile of material are such that the diffusion of oxygen from the outside of the pile of material to the probe is not significant. This may serve to ensure that equation (2) provides an acceptable estimate of the actual IOR, by satisfying the assumption that diffusion of oxygen from outside the pile into interstitial voids is insignificant. The condition for ensuring that this assumption is satisfied is given by:

$$l \gg \sqrt{D_o t} \quad (4)$$

where:

l is the distance of the probe from the surface of the pile;

D_o is the effective diffusion coefficient of oxygen in the gas within the pile; and

t is the time after aeration has ceased.

The method according to the first embodiment of the present invention offers the advantage that pile oxidation performance can be determined on an ongoing basis, without having to rely on external indicators, which show a significant time lag behind actual pile performance.

When IOR or a spatial distribution thereof is used in a method for constructing, and controlling the operating conditions of, a pile of material, a computer model may be used to determine at least one parameter of construction of the pile. The model may be based on a deterministic formulation of multiphase flow through porous media, for example a computer model as described in Australian Patent No. 6083790, the contents of which are incorporated herein by reference, or a computer model similar to that model. Commonly,

Alternatively or additionally, the calculated IOR, optionally together with other data gathered from the same or a different probe(s), may be used for computer modelling or simulation of the operation of the pile of material, in order to determine the effect of specific conditions on the operation of the pile of material. The computer modelling may use the same model as that described above or it may use a different model.

In a system for determining a rate of change in a gaseous oxygen concentration within of a pile of material, according to the present invention, the means for measuring the gaseous oxygen concentration may comprise a tube through which a sample of the gas to be measured is conveyed to a sensor capable of measuring oxygen concentration.

5 When a plurality of the probes are used, each tube may be connected to a separate oxygen sensor, or one or more of the oxygen sensors may be connected to a plurality of tubes. There may additionally be means to control from where in the pile the sample of gas was taken. The means to control may comprise a plurality of valves linked to a means to control the valves, for example a computer. There may optionally be one or more filters,
10 either at the end of the tube(s), at some location within the tube(s) or near the oxygen sensor(s), the filters being capable of removing materials detrimental to the performance of the oxygen probe or sensor, for example particulate material, dust, CO₂ and moisture. In a system for determining a spatial distribution of rates of change in gaseous oxygen concentration within a pile of material, the plurality of probes may be arranged within the
15 pile in a predetermined array.

If more than one probe is connected to a particular sensor, then there may additionally be means to selectively direct gas from one probe to the sensor at any particular time. The system may include means for using at least one of the calculated IORs, the oxygen concentration and the temperature to make decisions concerning
20 operation of the pile. The means to make decisions may comprise means to adjust the operating conditions of the pile of material.

In a particular aspect of the invention, there is provided a system for controlling the operation of a pile of material, comprising:

- (i) one or more probes capable of being located within the pile of material;
- 25 (ii) means for altering the gaseous oxygen concentration in at least a part of a pile of material and means for stopping the altering;
- (iii) means to determine (a) rate(s) of oxidation of material within the pile;
- (iv) means to determine the IOR or a spatial distribution of the IOR within the pile;
- 30 (v) means to determine temperature and optionally a spatial distribution of temperature within the pile;

- (vi) means for controlling the provision of the one or more materials to the pile.

The system may include means for coupling the probes of (i) to the means to determine of (iii) and (v). The one or more materials in (vi) may be air or other gas, water or other aqueous liquid, for example. The means of (iii), (iv) and (v) may include a
5 computer. The means of (vi) may be a computer linked to means for providing air or other gas to the pile and/or means for contacting one or more portions of the pile of material with water or aqueous liquid.

The probe(s) may be capable of measuring gaseous oxygen concentration, and
10 optionally they may also be capable of measuring temperature, and optionally also other parameters of relevance to the operation of the pile of material. Alternatively, separate probes for measuring gaseous oxygen concentration, temperature and optionally the other parameters may be located close to each other in a group. There may be between 2 and 70 or more of the probes or groups of probes within the pile. The number of probes will
15 depend on the size of the pile and the chosen distance between probes. In particular there may be between 2 and 50 or more of the probes or groups of probes within the pile. More particularly there may be between 2 and 30 or more of the probes or groups of probes within the pile. Even more particularly there may be between 2 and 20 or more of the probes or groups of probes within the pile. Still more particularly there may be between 2
20 and 10 or more of such probes or groups of probes within the pile. Preferably, any one location within the pile at which oxygen concentration is measured will be between 0.5 and 10 metres or more from any other such location. More preferably any two such locations will be between 0.5 and 7.5 metres apart, still more preferably between 0.5 and 5 metres apart, even more preferably between 1 and 4 metres apart, even more preferably
25 between 1 and 3 metres apart and still more preferably between 1 and 2 metres apart.

The means for providing air or other gas to the pile may be capable of providing the air or other gas selectively to different portions of the pile at different rates. Similarly the means for providing water or other aqueous liquid to the pile may be capable of providing the water or other aqueous liquid to different portions of the pile at different rates. The
30 system may also include means for adjusting other parameters of relevance to the operation of the pile in response to the determined IOR or spatial distribution of the IOR in the pile. The means for determining the IOR or a spatial distribution of the IOR may be

a computer. The means for controlling the provision of air or other gas and of water or other aqueous liquid to the pile may comprise a series of valves connected to the computer. The means for controlling the provision of air or other gas and/or water or other aqueous liquid to the pile may comprise means to control the provision of the air or other gas and the water or other aqueous liquid selectively to different portions of the pile at different rates.

Similar mathematics to that shown above has been derived for piles of sulfidic materials by Bennett and Ritchie (*Hydrometallurgy*, 72 (2004), 51-57). The oxygen concentration, $u^*(x^*, y^*, t)$, in the gas phase in the pore space of a heap of sulfidic material may be calculated using:

$$\frac{\partial(\epsilon_g u^*)}{\partial t} + \text{div} \left[u^* \epsilon_g \bar{v}_g - D_o \nabla u^* \right] = -\beta_g S^s(\omega_o^g, \omega_s^s, T) \tag{5}$$

where

D_o = the oxygen diffusion coefficient;

$S^s(\omega_o^g, \omega_s^s, T)$ = the intrinsic oxidation rate of the sulfidic material;

T = the temperature at the point (x^*, y^*) ;

β_g = the ratio of the mass of oxygen used to the mass of sulfur consumed in sulfide oxidation;

x = a horizontal axis;

y = the vertical axis; and

the dimension of the heap in the other horizontal direction is large compared to the x, y dimensions.

The mass fraction of oxygen, ω_o^g , in the gas phase and the mass fraction, ω_s^s , of sulfide sulfur in the solid phase are also functions of x^*, y^* and t .

Using the dimensionless variables:

$$x = x^*/X_o, \quad y = y^*/h, \quad S = S^s/S_o^s \quad \text{and} \quad u = u^*/u_o;$$

where

X_o = the width of the heap (m);

h = the height of the heap (m);

u_o = the oxygen concentration in air (kg m^{-3}); and

S_o^s = the maximum value of the intrinsic oxidation rate ($\text{kg (O}_2\text{) m}^{-3} \text{ s}^{-1}$)

Equation 5 may thus be written as:

$$\frac{\partial(\epsilon_g u)}{\partial t} + \frac{1}{h} \text{div} \left[u \epsilon_g \bar{v}_g - \frac{D_o}{h} \left(\frac{\partial u}{\partial y} + \frac{h}{X_o} \frac{\partial u}{\partial x} \right) \right] = -\frac{\beta_g S_o^s}{u_o} S(\omega_o^g, \omega_s^s, T) . \tag{6}$$

Examination of Equation 6 shows that, in order to achieve a high oxidation rate at all points in a pile of sulfidic material, the second term in the square brackets must be much smaller than the first. Thus the specific gas discharge rate, $\epsilon_g \bar{v}_g$, should be much greater than D_o/h . For a typical pile the latter term is commonly about 5×10^{-7} m/s. This value of specific discharge rate is readily achievable in practice. It can be shown that for the oxidation rate throughout the heap to be near the maximum value, the specific discharge rate should be about 10^{-4} m/s. The gas discharge rate should be high enough for the second term in Equation 6 to balance the third term. Such discharge rates can be achieved by providing air to the base of the pile. The pressures required are quite modest (between about 100 and 10,000 Pa) for a gas permeability of greater than about 10^{-11} m². When the supply of air is switched off, the gas specific discharge rate decreases sharply. In most large waste rock piles, gas transport is dominated by diffusion at locations sufficiently far from the sides of the pile. This is likely to be the case for most biooxidation and bioleach heaps as well. When aeration is ceased, the first term in the square brackets of Equation 6 can be neglected, and Equation 6 becomes,

$$\frac{\partial(\epsilon_g u)}{\partial t} = -\frac{D_o}{h^2} \left[\frac{\partial^2 u}{\partial y^2} + \frac{h}{K_o} \frac{\partial^2 u}{\partial x^2} \right] - \left(\frac{\beta_g S_o^s}{u_o} \right) S(\omega_o^g, \omega_g^s, T). \quad (7)$$

Since in most piles the width is usually much greater than the height, the second term in the square brackets in Equation 7 can be neglected. Typical values for the oxygen diffusion coefficient may be about 5×10^{-6} m² s⁻¹, and 10 m for the height of the pile. Thus the multiplier outside the square brackets may commonly be about 5×10^{-8} s⁻¹. To ensure that a large fraction of sulfide sulfur is oxidised in a biooxidation heap in a typical time of about 6 months, the intrinsic oxidation rate should be high, for example about 5×10^{-6} kg (O₂) m⁻³ s⁻¹. The multiplier $\left(\frac{\beta_g S_o^s}{u_o} \right)$ will then about 7×10^{-4} s⁻¹. Thus the IOR dominates the behaviour of the oxygen concentration in the pore gas over time as the system relaxes from the pseudo steady state after aeration has been stopped. Consequently, measurement of the rate of decrease of the oxygen concentration at a point in the heap provides a measure of the IOR of the sulfidic material at that point. Measurement of the rate of change of the oxygen concentration at a variety of locations throughout the heap provides a distribution of sulfide sulfur oxidation rates through the heap, since the stoichiometry of the sulfide oxidation reactions is known.

Waste rock dumps are typically much higher than bioheaps, commonly being up to 25m or more, but the oxidation rate of the sulfidic material is typically much lower, commonly about $1 \times 10^{-8} \text{ kg (O}_2\text{) m}^{-3} \text{ s}^{-1}$. The multiplier $\left(\frac{\beta_g S_o^s}{u_o} \right)$ at about 7×10^{-8} is still greater than (D_o/h^2) at 8×10^{-9} . Thus it is still probable that immediately after cessation of drilling the time dependence of the oxygen concentration near the probe hole may be described by a simple rate equation.

A preferred mode of carrying out the invention is described below with reference to Figures 1a, 1b, 2a, 2b and 3. In this description, the numbers of the following: probes, collections of probes, groups of probes, strings of probes, holes, outlets for water and air, and other components described; are shown by way of example only and should not be taken as in any way limiting the invention.

In the case of a waste rock pile, illustrated diagrammatically in Figure 1a, holes 102, 104 and 106 are drilled vertically (or alternatively they may be drilled at some different angle) into a pile of waste rock 101. A typical waste rock pile may be between 100 and 3000 metres wide and between 10 and 100 metres or more high. The drilling of holes into the pile is shown in greater detail in Figure 2. Collections of probes 112, 114 and 116 (Figure 1a), comprising probes capable of determining gaseous oxygen concentration, optionally together with temperature and/or other parameters relevant to the operation of the pile, are located into holes 102, 104 and 106. Collections of probes 112, 114 and 116 comprise groups of probes at different depths within the holes 102, 104 and 106. This is shown in greater detail in Figure 3. The probes of collections 112, 114 and 116 are located sufficiently far from the surface of the pile that diffusion of oxygen from outside the pile is negligible during the period of a measurement. Although this depends on a number of factors (Equation 4) a typical minimum distance to the surface of the pile may be about 0.5 to 1 metre. Collections of probes 112, 114 and 116 (which include collections of tubes 152, 154 and 156) send electrical data to computer 140 by means of collections of electrical cables 122, 124 and 126 and send gas samples to oxygen detectors 142, 144 and 146 by means of collections of tubes (probes) 152, 154 and 156. It should be noted that certain types of probe, for example thermistors, require a device such as a signal transducer, to convert a signal from the probe to a signal suitable as input for a computer. It will be understood that such devices, although not shown in the

Figures, are in fact present when necessary. Oxygen detectors 142, 144 and 146 are also connected to collections of electrical cables 122, 124 and 126 and transmit data through them to computer 140. Alternatively, signals may be sent from collections of probes 112, 114 and 116 and oxygen sensors 142, 144 and 146 to the computer 140 by means of transmitters or other convenient method. Optionally there may be more than three or less than three oxygen detectors connected to collections of oxygen tubes 152, 154 and 156. For example, there may be 1, 2, 4, 5 or 6 or more oxygen detectors. During the drilling of holes 102, 104 and 106, air is provided to the holes as shown in Figure 2 (for a typical hole 215). This creates a zone of aeration 235 in which the oxygen concentration is approximately the same as in the outside atmosphere. As soon as is convenient after insertion of probes into holes 102, 104 and 106, the holes are sealed by backfilling with backfills 132, 134 and 136, and data acquisition from collections of probes 112, 114 and 116 is commenced. The data acquired over a period of approximately 10 to 12 hours is sent to the computer 140 which then determines a rate of change in oxygen concentration for each oxygen probe. From that and from other data the computer 140 can then determine a spatial distribution of the IOR and optionally also of other parameters. Alternatively, raw data may be stored in the computer for subsequent off line analysis. This alternative may be commonly used in the case of waste rock piles.

During construction of a biooxidation/bioleach pile, illustrated diagrammatically in Figure 1b, air pipes 242, 244 and 246, each of which may have one or more air outlets, are initially laid on the site. The pipes are fitted with air flow control valve 252, 254 and 256, which are connected to computer 220 by cables 262, 264 and 266. Alternatively, signals may be sent from the computer 220 to the valves 252, 254 and 256 by means of a transmitter or other convenient method. Rock is then laid on top of pipes 242, 244 and 246 to form pile 201. Strings of probes 202 (including tubes 223, 225, 227), 204 (including tubes 229, 231 and 233) and 206 (including tubes 235, 237 and 239) are located in pile 201 as it is being constructed. Strings of probes 202, 204 and 206 contain individual groups of probes 222 (including tube 223), 224 (including tube 225), 226 (including tube 227), 228 (including tube 229), 230 (including tube 231), 232 (including tube 233), 234 (including tube 235), 236 (including tube 237) and 238 (including tube 239). Each of these groups of probes contain individual probes which are capable of measuring gaseous oxygen concentration, and optionally temperature and/or other parameters relevant to the operation of the pile. The strings of probes in Figure 1b are

each similar to the collection of probes shown diagrammatically in Figure 3, although they are located at an angle in the pile, and are located in the material of pile 201 rather than being located in a backfilled hole. The groups of probes 222, 224, 226, 228, 230, 232, 234, 236 and 238 are located sufficiently far from the surface of the pile that
5 diffusion of oxygen from outside the pile is negligible during the period of the measurement. Although this depends on a number of factors (Equation 4) a typical minimum distance to the surface of the pile may be about 0.5 to 1 metre. Probes 223, 225, 227, 229, 231, 233, 235, 237 and 239 within groups 222, 224, 226, 228, 230, 232, 234, 236 and 238 respectively are designed to measure oxygen concentration and comprise a
10 tube for conveying air samples to oxygen detectors 247, 248 and 249. Alternatively, there may be more than three or less than three oxygen detectors connected to collections of oxygen tubes 223, 225, 227, 229, 231, 233, 235, 237 and 239. For example, there may be 1, 2, 4, 5 or 6 or more oxygen detectors. The oxygen detectors are located externally to pile 201. This is shown in greater detail in Figure 3. Groups of electrical cables 212, 214
15 and 216 transmit data from probes 202, 204 and 206 and from detectors 247, 248 and 249 to computer 220. Alternatively, data may be sent to the computer 220 by means of a transmitter or other convenient method. Water pipes 272, 274 and 276 are located on or above the top of pile 201. Each of pipes 272, 274 and 276 may have one or more outlets for water. The flow of water through pipes 272, 274 and 276 may be controlled by valves
20 282, 284 and 286, which are connected to computer 220 by electrical cables 292, 294 and 296. Alternatively, signals may be sent from the computer 220 to valves 282, 284 and 286 by means of a transmitter or other convenient method. The water supplied to pipes 272, 274 and 276 may have various materials, for example acid, ferric ions and/or other ionic species or other chemicals dissolved in it for the purpose of improving the operation of
25 the pile.

Prior to determining the IOR or a spatial distribution of the IORs, air is passed through pipes 242, 244 and 246 in order to provide oxygen to the parts of the pile in which probes 223, 225, 227, 229, 231, 233, 235, 237 and 239 are located, such that the oxygen concentrations at those locations are approximately the same as the oxygen
30 concentration in the atmosphere outside the pile. The air flow through pipes 242, 244 and 246 is then stopped by closing valves 252, 254 and 256. These valves remain closed throughout the period in which data is acquired for determining the IOR or a spatial distribution of the IORs. Alternatively, air flow may be controlled by turning on or off blowers, fans or other means for providing the air to pipes 242, 244 and 246. Either

before the stopping air flow or immediately after it, a measurement of oxygen concentration is made by each of the probes in the pile, using detectors 247, 248 and 249 to measure the oxygen concentration of samples of gas taken by probes 223, 225, 227, 229, 231, 233, 235, 237 and 239. At the same time, measurements of temperature and any other desired parameters are made by detectors in strings of probes 202, 203 and 204. The data so acquired is sent to the computer 220 by means of groups of cables 212, 214 and 216. Measurements of oxygen concentration, temperature and optionally other parameters are then made at a number of times over a period of approximately 10 hours. Data from these measurements are transmitted to the computer 220. The computer then processes that data to determine the IOR or a spatial distribution of the IORs, and optionally also other operating conditions of pile 201 or spatial distributions of the other conditions. It may then determine what changes need to be made to the operating conditions of pile 201 to improve its operation. The computer may then send signals to valves 252, 254, 256, 282, 284 and 286, and optionally to other devices capable of influencing the operating conditions of all or part of pile 201, in such a way as to improve the operating conditions in all or part of the pile 201.

With reference to Figure 1c, pile 405 comprises first part 407, with strings 410, 412 and 414 and second part 409, with strings 416, 418 and 420. Air pipes 430, 432 and 434 are located below first part 405 for aerating first part 405, and air pipes 436, 438 and 440 are located below the second part 407 for aerating second part 407. These air pipes are fitted with air flow control valves 450, 452 and 454, and air flow control valves 456, 458 and 460 respectively. These valves are connected to computer 470 by cables 480, 482, and 484, and 486, 488 and 490 respectively. The individual probes in strings 410, 412 and 414 are connected to oxygen detector 415 by a collection of tubes 422, and the individual probes in strings 416, 418 and 420 are connected to oxygen detector 425 by a collection of tubes 427. Oxygen detectors 415 and 425 are connected to computer 470 by cables 490 and 492 respectively.

In constructing pile 405 air pipes 430, 432 and 434, fitted with valves 450, 452 and 454 and cables 480, 482, and 484 are initially laid on the site of the pile. As the material of first part 407 is deposited on the site, strings 410, 412 and 414, connected to computer 470 by collection of cables 422, are incorporated in pile 405. In a subsequent construction step, air pipes 436, 438 and 440, fitted with valves 456, 458 and 460 and cables 486, 488 and 490 are laid on or in the top of first part 407. As the material of

second part 409 is deposited on top of first part 407, strings 416, 418 and 420, connected to computer 470 by collection of cables 427, are incorporated in second part 409. Once pile 405 has been constructed, IOR of the pile, or a distribution of IORs, may be determined in a manner similar to that described for Fig. 1b. IOR, or a distribution of IORs, may determined separately for first part 407 and for second part 409, or it may be determined for pile 405 as a whole. In order to determine a distribution of IORs for pile 405 as a whole, the pile is initially aerated through air pipes 430, 432, 434, 436, 438 and 440, by opening valves 450, 452, 454, 456, 458 and 460, under control from computer 470 via cables 480, 482, 484, 486, 488 and 490, and subsequently the valves are closed to stop the aeration. Either before the stopping air flow or immediately after it, a measurement of oxygen concentration is made by each of the probes strings 410, 412, 414, 416, 418 and 420, using detectors 415 and 425 in to measure the oxygen concentration. The data so acquired is sent to computer 470 by means of cables 490 and 492. Measurements of oxygen concentration, temperature and optionally other parameters are then made at a number of times over a period of approximately 10 hours. Data from these measurements are transmitted to the computer 470. The computer then processes that data to determine a spatial distribution of the IORs.

Figure 2 shows a diagrammatic representation of a cavity 215a formed in the porous material of pile 205a. Drill bit 225a, which may for example be a rotary percussion air blast drill bit, is used to form cavity 215a, and in doing so supplies air into the cavity. The air may move through the porous material of pile 205a as shown by the arrows in Figure 2, such that the aerated region 235a has an oxygen concentration approximately equal to that of ambient air. The radius of aeration is represented by the radial distance from the hole to the boundary of the aerated region. In order to provide sufficient time over the length of a 10 hour measurement of the IOR, the radius of aeration should be preferably at least 5 metres.

Figure 3 shows a diagrammatic representation of one of the holes 102, 104 and 106 of Figure 1a, containing probes and backfill 340. As noted previously, this shares many features in common with the strings of probes 202, 204 and 206 of Figure 1b. In Figure 3, a plurality of probes is inserted into hole 350, which is located in pile 301. The probes are organised in groups of probes 352 and 354 which are located at different depths within hole 350. Each of groups 352 and 354 comprise probes for measuring gaseous oxygen concentration (302 and 304), temperature (306 and 308) and another relevant

parameter (310 and 312). Probes 306, 308, 310 and 312 are connected to computer 320 by electrical cables 326, 328, 330 and 332. Alternatively, signals may be sent to the computer 320 by means of a transmitter or other convenient method. Oxygen concentration probes 302 and 304 comprise tubes 322 and 324 which can transmit
 5 samples of gas from the vicinity of groups 352 and 354 to an oxygen detector 318, which is conveniently located outside the pile. Oxygen detector 318 comprises pumps 314 and 316, which pump gas samples from tubes 322 and 324 to the oxygen sensor 319 located within detector 318. Valves 315 and 317 (controlled by computer 320 using a means not shown here for reasons of simplicity) select which of the probes is in service at a
 10 particular time. Signals from oxygen sensor 318 are transmitted to computer 320 using electrical cable 323, or using a transmitter or similar convenient means. Temperature probes 306 and 308 are preferably thermistors or thermocouples.

Figure 4a shows the dependency of oxygen concentration upon time within a
 15 biooxidation/bioleach pile for two different examples of the operational conditions of the pile (pile 1 and pile 2) as obtained from numerical modelling. Figure 5a shows the dependency on time of the relative deviation D_r of the approximate value of the IOR from its more precise value S'_o (calculated from Equation 1):

$$D_r = (S'_o - S''_o) / S'_o \quad (5)$$

20 The estimated value of the IOR, obtained using Equation 2, agrees well with the more precise value from Equation 1 if the measurements of oxygen concentration are conducted within several hours of cessation of aeration of the pile and within the bulk of the pile. Typically for a biooxidation/bioleach pile, measurements would commence immediately following the cessation of aeration, or alternatively one or more
 25 measurements may be made before the cessation. The condition for determining the minimum distance of probes from the surface of the pile is given by Equation 4. These conditions serve to ensure that diffusion of oxygen from outside the pile is minimal during the period of the measurement. Curves 5, 9, 11, 10 and 1 in Figure 4a correspond to locations which are close to the pile surface, and consequently which violate the
 30 conditions described above. The other curves, 2–4 and 6–8, correspond to locations within the bulk of the pile. The time period within which reliable measurements may be obtained depends on the location of probes from which the measurements are taken.

Consequently in Figure 4a, the locations within the pile corresponding to curves 5, 9, 11, 10 and 1 have oxygen concentrations that are higher than would be expected from Equation 2, since the oxygen at those locations has been augmented by oxygen diffusing from outside the pile. Figure 5a shows that the deviation of the calculated IOR from exact value of the IOR increases with time, as the greater time periods allow more oxygen to diffuse from outside the pile to the location(s) of the probe(s). Curves 2-4 and 6-8 do not show these deviations from the theoretical values since the locations of the probes are sufficiently far from the surface of the pile that the amount of oxygen that can diffuse to those locations over the time of the test is insignificant.

Figure 4b illustrates the dependency of oxygen concentration upon time as a function of depth and of size of the aerated region, as obtained from numerical modelling of a waste rock pile such as that shown diagrammatically in Figure 1a. Figure 5b shows the deviation of the calculated oxygen concentrations of Figure 4b from the more precise values obtained from Equation 1. In Figure 4b and Figure 5b, data is shown for 5 different depths within a 20 metre deep pile: curves 1 to 5 represent data at distances of 1.0, 5.5, 10.0, 14.5 and 19.0 metres respectively from the base of the pile. Three sets of such data are shown: data represented by dashes describes a hole with a 2 metre radius of the zone of aeration, data represented by dash-dots is for a 3 metre radius and solid lines represent a 5 metre radius. Figure 4b shows that the larger the region of aeration, the smaller the decline in oxygen concentration. Thus for a 2 metre radius of aeration, the oxygen concentration drops substantially in only a few hours, since there is a smaller reservoir of oxygen in the surrounding material. By contrast, for a 5 metre radius of aeration, the decline in oxygen concentration is much smaller and is approximately linear over time during the 10 hour period described. Correspondingly, the deviation of the approximate IOR from the more precise value of the IOR from Equation 1 is greater when the radius of aeration is smaller. For a radius of aeration of 5 metres (solid lines), the relative deviation is small and relatively constant. Figure 4b also shows that at a depth of only 1 metre from the surface (curve 5), the oxygen concentration is higher than for the other four deeper locations. This is due to augmentation of the oxygen due to diffusion from outside the pile. For small radii of aeration (2 and 3 metres), the relative deviation of the IOR at 1 metre depth, shown in Figure 5, is less than for the deeper locations, since the diffusion of oxygen from outside the pile partially offsets the depletion of oxygen due to the small size of the oxygen reservoir. In the case of a 5 metre radius of aeration, location 5, near the

surface, shows a slight positive relative deviation after some time, since the depletion is small due to a larger region of aeration, and diffusion from outside the pile more than compensates for it.

Figure 6 shows a graph of the normalised IOR as a function of normalised oxygen concentration as described by the Monod formula (Equation 1). This graph describes the behaviour of the IOR when the actual material being tested is the same. It shows that the IOR depends on oxygen concentration, so that when oxygen concentration is below the atmospheric level, the IOR will be lower than its maximum value. It further shows that the deviation of the IOR from its maximum value is relatively slight for higher values of oxygen concentration. For example, when oxygen concentration is only 50% of the atmospheric level, the IOR is over 90% of its maximum level. However at low levels of oxygen concentration, the change of the IOR in response to a relatively small change in oxygen concentration is much larger.

Claims:

1. A method of determining a rate of change in a gaseous oxygen concentration within a pile of material, said pile of material comprising both solid phase and gas phase, comprising the steps of:

- 5 (i) altering the gaseous oxygen concentration in at least a part of the pile of material;
- (ii) measuring the gaseous oxygen concentration in at least one location within that part of the pile of material altered by said gas containing oxygen;
- 10 (iii) repeating said measuring a sufficient number of times at said at least one location to enable determination of a rate of change in the gaseous oxygen concentration, wherein the altering of step (i) is ceased at least prior to said repeating; and
- (iv) determining the rate of change in the gaseous oxygen concentration in
15 said at least one location.

2. The method of claim 1 wherein said altering comprises passing a gas containing oxygen through said at least a part of said pile

20 3. The method of claim 1, further comprising the step of determining an intrinsic oxidation rate (IOR) at said at least one location in the pile.

4. The method of claim 3 wherein the equation:

$$S_o^a = -\frac{\varepsilon \rho^{in}(0)(1 - \Omega_o) \partial \omega_o}{[1 - \omega_o(t)]^2 \partial t}$$

25 is used to calculate an approximate value of the IOR of oxidisable material in the pile, wherein:

S_o^a is an approximate value of the IOR;

ε is the volume fraction of the gas phase in the pile of oxidisable material; and

30 $\rho^{in}(0)$ is the intrinsic gas density of the gas at the location in the pile at which the IOR is determined, immediately after the altering of the gaseous oxygen concentration therein.

5. The method of claim 2 wherein the concentration of oxygen in the gas containing oxygen is sufficient to make the oxygen concentration in the at least one location approximately equal to the concentration of oxygen in air.

5 6. The method of claim 1 comprising the steps of aerating at least a part of the pile of material and of ceasing said aeration before the step of measuring the gaseous oxygen concentration.

7. The method of claim 1 wherein the step of measuring comprises the steps of :
10 (i) transferring a sample of gas from the region surrounding the probe to a location external to the pile;
(ii) passing said sample of gas to a device capable of measuring gaseous oxygen concentration; and
(iii) using said device to measure a gaseous oxygen concentration of said
15 sample of gas.

8. The method of claim 1 wherein the time at which each of the steps of measuring are performed is recorded.

20 9. The method of claim 1 wherein the step of altering comprises forming a cavity in the pile of material such that the oxygen content of the gas phase in said cavity and in the surrounding region is substantially the same as the oxygen concentration in the ambient atmosphere outside the pile of material.

25 10. The method of claim 9 wherein a probe for measuring oxygen is inserted into the cavity.

11. The method of claim 1 wherein the rate of change of oxygen concentration is measured a plurality of times, and the change with time in at least one of the IOR and the
30 rate of change of oxygen concentration is used to estimate at least one of:

(i) a change in the rate of conversion of metal substances in the pile to metal substances from which the metal is recoverable, as a function of time,

- (ii) a change in the rate of production of pollutants in the pile as a function of time, and
- (iii) an effective lifetime of the pile.

5 12. A method of determining a spatial distribution of rates of change of gaseous oxygen concentration within a pile of material, said pile of material comprising both solid phase and gas phase, comprising the steps of:

- (i) locating a plurality of probes in the pile;
- (ii) altering the gaseous oxygen concentration surrounding at least two of
10 said probes;
- (iii) measuring an oxygen concentration in the gas surrounding the at least two of said probes in the pile;
- (iv) determining a rate of change in oxygen concentration of the gas surrounding the at least two of said probes in the pile wherein said
15 determining comprises measuring the oxygen concentration in the gas surrounding at least two of the probes after the altering of step (ii) has been stopped; and
- (v) determining a spatial distribution of rates of change in gaseous oxygen concentration in the pile.

20

13. The method of claim 12 wherein said altering comprises passing a gas containing oxygen through the locations of the at least two of said probes.

14. The method of claim 12 additionally comprising the step of determining a
25 spatial distribution of IORs within the pile.

15. A method of controlling the operating conditions of a pile of material, said pile of material comprising both solid phase and gas phase, comprising:

- (i) determining information selected from the group consisting of an IOR
30 of oxidisable material in the pile and a spatial distribution of IORs of oxidisable material in the pile; and
- (ii) adjusting at least one operating condition of the pile.

16. The method of claim 15 wherein the step of adjusting comprises a process selected from the group consisting of aerating at least one portion of the pile and contacting at least one portion of the pile of material with a liquid selected from the group consisting of water and an aqueous liquid.

5

17. A method for constructing, and controlling the operating conditions of, a pile of material, said pile of material comprising both solid phase and gas phase, comprising:

- (i) determining at least one property of the material;
- (ii) using the at least one property in a model to determine a value of at least one parameter of construction of the pile of material;
- (iii) constructing the pile using the value of said at least one parameter of construction;
- (iv) determining information selected from the group consisting of an IOR of oxidisable material in the pile and a spatial distribution of IORs of oxidisable material in the pile; and
- (v) adjusting the operating conditions of the pile.

10

15

18. The method of claim 17 wherein the at least one property of the material is selected from the group consisting of porosity, gas permeability, sulfur content, IOR, and a combination of these.

20

19. The method of claim 17 wherein the model is a computer model based on a deterministic formulation of multiphase flow through porous media.

25

20. The method of claim 17 wherein the step of adjusting includes a process selected from the group consisting of aerating the pile and contacting the pile of material with a liquid selected from the group consisting of water and an aqueous liquid.

30

21. A system for determining a rate of change in gaseous oxygen concentration within of a pile of material, said pile of material comprising both solid phase and gas phase, said system comprising:

- (i) means for altering the gaseous oxygen concentration in at least a part of a pile of material;

- (ii) means for measuring the gaseous oxygen concentration within the pile of material;
- (iii) means for repeating the measuring of the gaseous oxygen concentration within the pile of material;
- 5 (iv) means for determining the rate of change in the gaseous oxygen concentration.

22. The system of claim 21 wherein the means for altering comprises means for passing a gas containing oxygen through said at least part of said pile, and means for
10 stopping said passing.

23. The system of claim 21 further comprising:

- (v) means for determining the time at which the measuring occurred; and
- (vi) means for determining an intrinsic oxidation rate at a location within the pile.

15

24. A system for determining a rate of change in gaseous oxygen concentration within of a pile of material, said pile of material comprising both solid phase and gas phase, said system comprising:

- (i) an aerator for altering the gaseous oxygen concentration in at least a part of a
20 pile of material;
- (ii) an oxygen measuring device for measuring the gaseous oxygen concentration within the pile of material;
- (iii) a controlling device for repeating the measuring of the gaseous oxygen concentration within the pile of material;
- 25 (iv) a computer for determining the rate of change in the gaseous oxygen concentration.

25. A system for determining a spatial distribution of rates of change in gaseous oxygen concentration within a pile of material, said pile of material comprising both solid
30 phase and gas phase, said system comprising:

- (i) a plurality of probes capable of being located in the pile;
- (ii) means for altering the gaseous oxygen concentration surrounding at least two of said probes;

- (iii) means for measuring the gaseous oxygen concentration in the gas surrounding the at least two of said probes in the pile;
- (iv) means for determining the rate of change in gaseous oxygen concentration of the gas surrounding said at least two of said probes in the pile; and
- 5 (v) means for determining a spatial distribution of rates of change in gaseous oxygen concentration in the pile.

26. The system of claim 25 wherein said means for altering comprises means for passing a gas containing oxygen through the location of the at least two of said probes, and means for stopping said altering

10

27. The system of claim 25 comprising means for determining a spatial distribution of IORs within the pile.

15

28. The system of claim 25 wherein more than one probe is connected to a particular means for measuring and there is additionally means to selectively direct gas from a probe connected thereto to the particular means for measuring at any particular time.

20

29. A system for determining a spatial distribution of rates of change in gaseous oxygen concentration within a pile of material, said pile of material comprising both solid phase and gas phase, said system comprising:

- (i) a plurality of probes capable of being located in the pile;
- 25 (ii) at least two aerators for altering the gaseous oxygen concentration surrounding at least two of said probes;
- (iii) an oxygen measuring device for measuring the gaseous oxygen concentration in the gas surrounding the at least two of said probes in the pile;
- (iv) a computer for determining the rate of change in gaseous oxygen concentration of the gas surrounding said at least two of said probes in the pile; and
- 30 (v) a computer for determining a spatial distribution of rates of change in gaseous oxygen concentration in the pile.

30. A system for controlling the operating conditions of a pile of material, said pile of material comprising both solid phase and gas phase, comprising:

- (i) means for determining information selected from an IOR of oxidisable material in the pile and a spatial distribution of IORs in the pile; and
- 5 (ii) means for adjusting at least one operating condition of the pile.

31. The system of claim 30 wherein the means for adjusting comprises means selected from the group consisting of means for aerating the pile and means for contacting the pile of material with a liquid selected from the group consisting of water and an aqueous liquid.

10

32. The system of claim 30 wherein the means for adjusting is capable of adjusting the operating conditions selectively in different portions of the pile.

33. A system for controlling the operating conditions of a pile of material, said pile of material comprising both solid phase and gas phase, comprising:

- 15 (i) a system according to claim 23 for determining information selected from an IOR of oxidisable material in the pile and a spatial distribution of IORs in the pile; and
- a device selected from the group consisting of an aerator and an irrigator for adjusting at
- 20 least one operating condition of the pile.

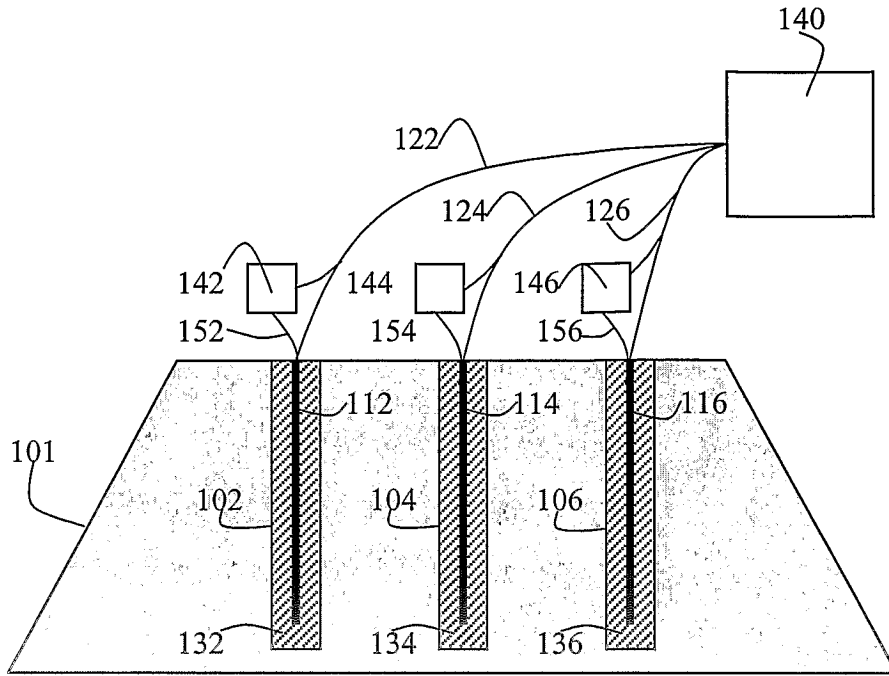

Figure 1a

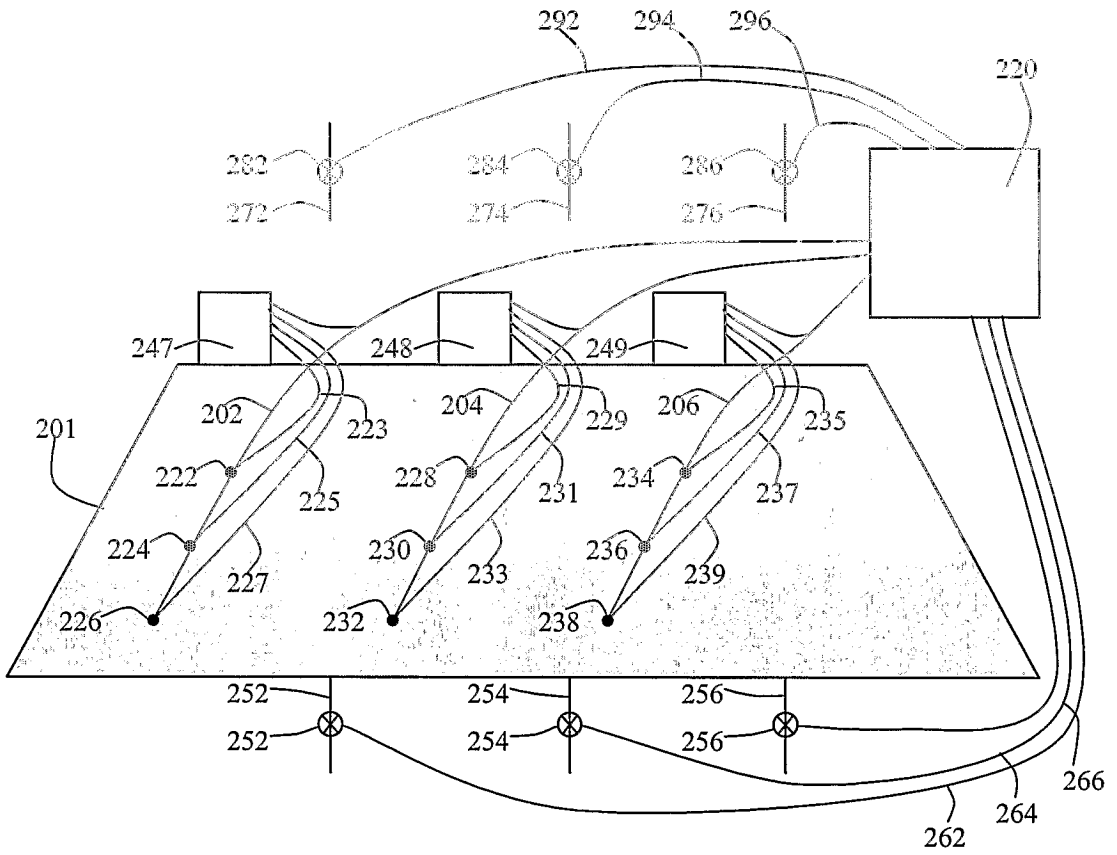

Figure 1b

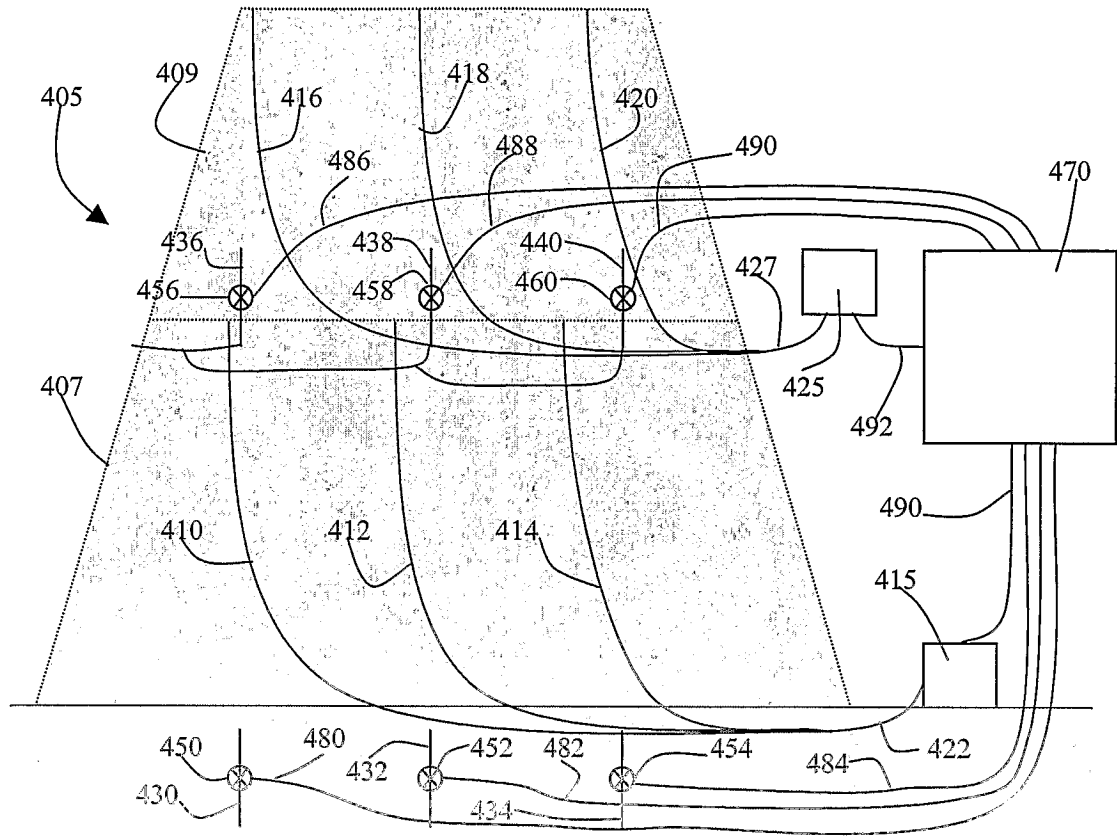

Figure 1c

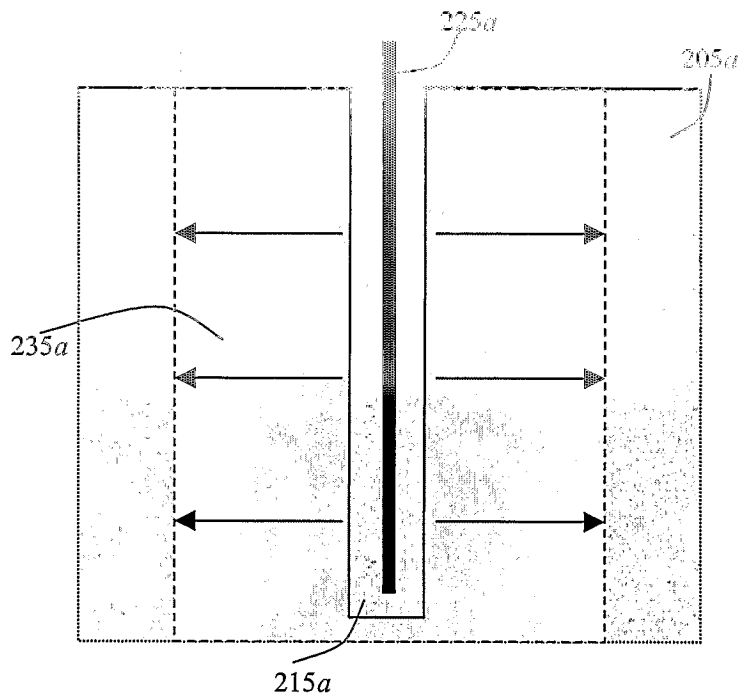

Figure 2

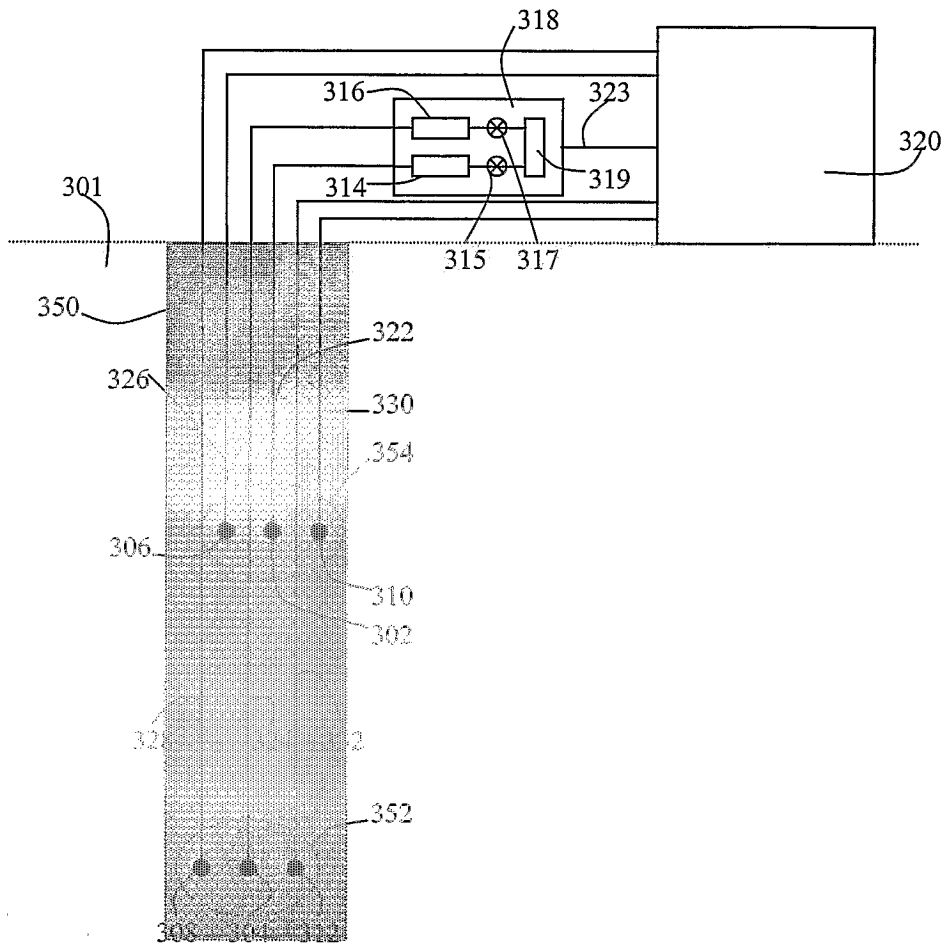

Figure 3

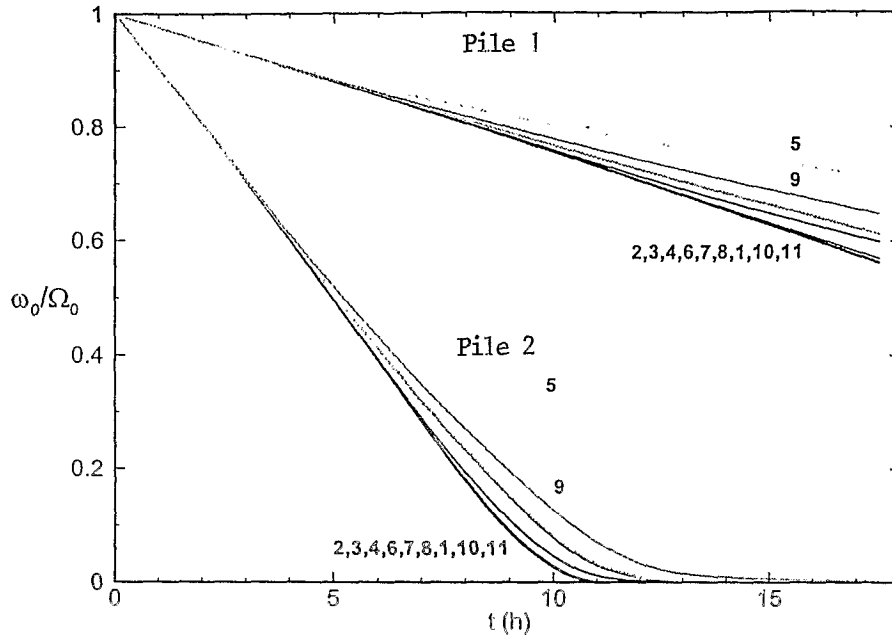

Fig. 4a

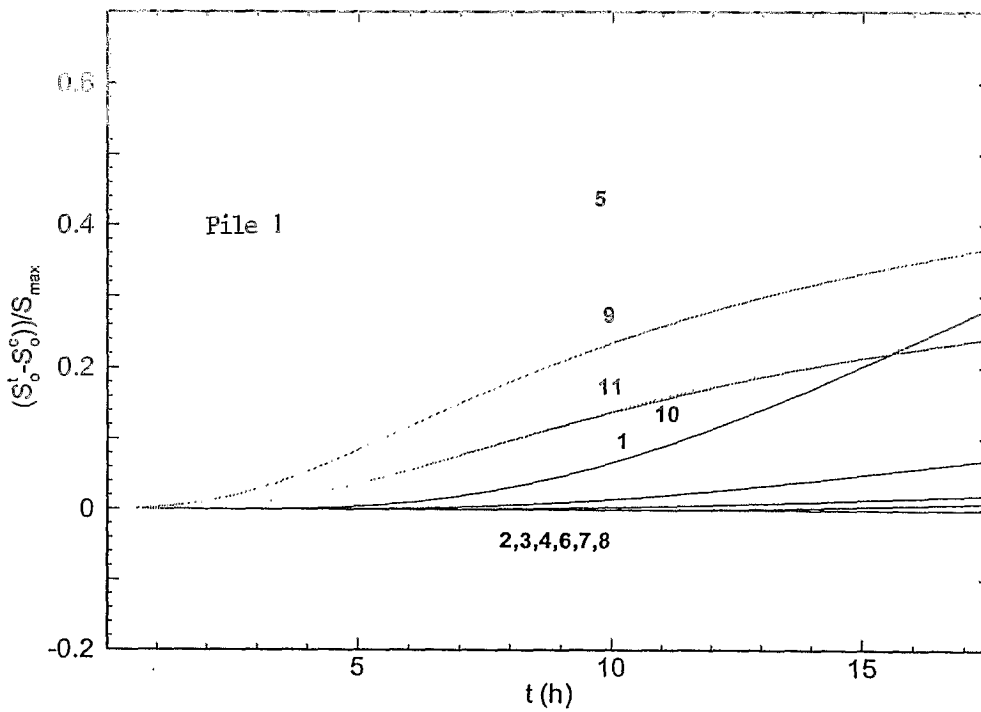

Fig. 5a

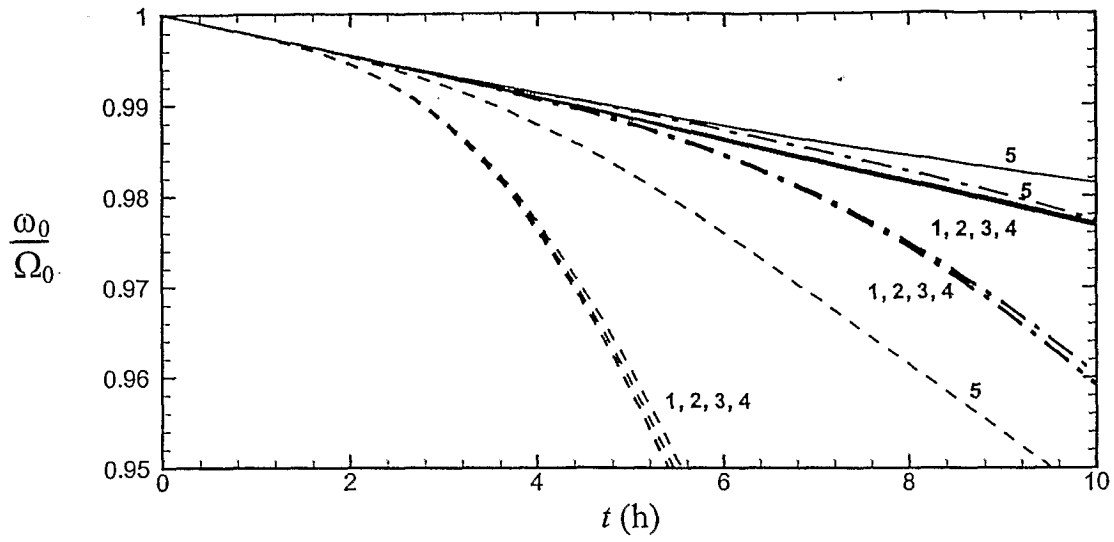

Fig. 4b

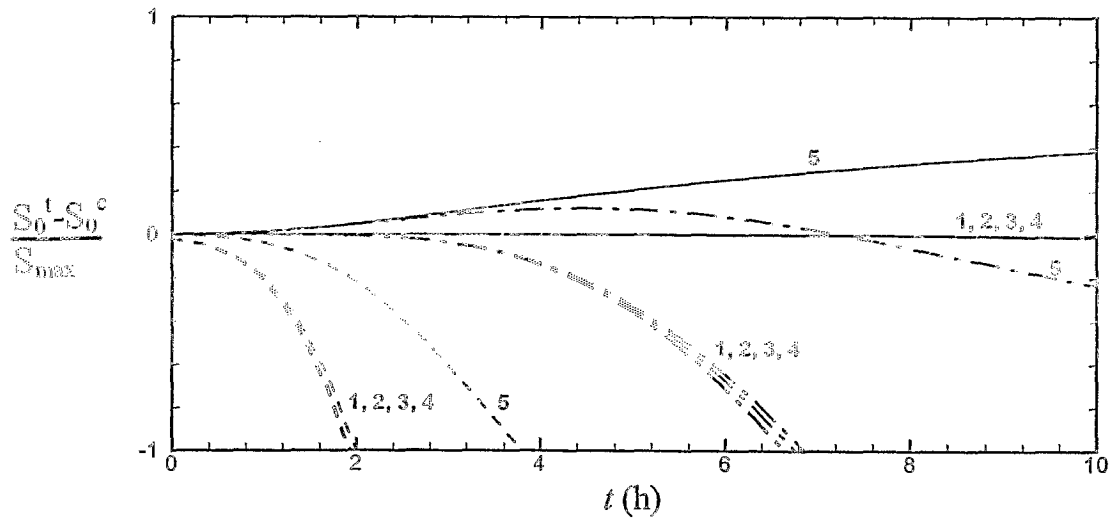

Fig. 5b

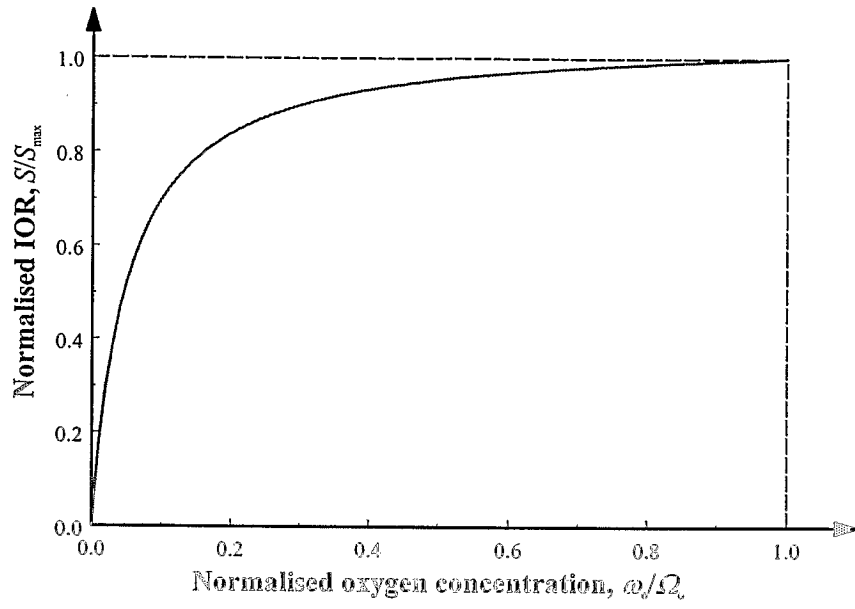

Fig. 6

INTERNATIONAL SEARCH REPORT

International application No.
PCT/AU2004/000151

A. CLASSIFICATION OF SUBJECT MATTER
Int. Cl. ⁷: G01N 33/24, C22B 3/18
According to International Patent Classification (IPC) or to both national classification and IPC

B. FIELDS SEARCHED

Minimum documentation searched (classification system followed by classification symbols)

Documentation searched other than minimum documentation to the extent that such documents are included in the fields searched

Electronic data base consulted during the international search (name of data base and, where practicable, search terms used)
DWPI, JAPIO Keywords: pile, heap, slurry, slag, mine, mining, dump, bioleach, biooxidation; oxygen/O2 concentration, oxidation rate/flux, ior; G01N 33/34, 7/02, C22B 3/-; aerat, irrigat
INTERNET Keywords: intrinsic oxidation rate

C. DOCUMENTS CONSIDERED TO BE RELEVANT

Category*	Citation of document, with indication, where appropriate, of the relevant passages	Relevant to claim No.
X Y	Bennett, J.W. et al., Comparison of Oxidation Rates of Sulfidic Mine Wastes Measured in the Laboratory and Field. Brisbane: Australian Centre for Mining Environmental Research, February 2000 Pages 2-7, 51-53 (& online copy retrieved from the Internet on 27 February 2004, URL: < http://www.acmer.com.au/research/attachments/ComparisonOxidationRatesSulfidicMineWastes.pdf >)	1-14, 21-29 33
X Y	AU 60837/90 A (AUSTRALIAN NUCLEAR SCIENCE AND TECHNOLOGY ORGANISATION) 14 February 1991 Pages 6-11, claim 22	15-20, 30-32 33

Further documents are listed in the continuation of Box C See patent family annex

* Special categories of cited documents:	"T" later document published after the international filing date or priority date and not in conflict with the application but cited to understand the principle or theory underlying the invention
"A" document defining the general state of the art which is not considered to be of particular relevance	"X" document of particular relevance; the claimed invention cannot be considered novel or cannot be considered to involve an inventive step when the document is taken alone
"E" earlier application or patent but published on or after the international filing date	"Y" document of particular relevance; the claimed invention cannot be considered to involve an inventive step when the document is combined with one or more other such documents, such combination being obvious to a person skilled in the art
"L" document which may throw doubts on priority claim(s) or which is cited to establish the publication date of another citation or other special reason (as specified)	"&" document member of the same patent family
"O" document referring to an oral disclosure, use, exhibition or other means	
"P" document published prior to the international filing date but later than the priority date claimed	

Date of the actual completion of the international search 27 February 2004	Date of mailing of the international search report 10 MAR 2004
---	---

Name and mailing address of the ISA/AU AUSTRALIAN PATENT OFFICE PO BOX 200, WODEN ACT 2606, AUSTRALIA E-mail address: pct@ipaaustralia.gov.au Facsimile No. (02) 6285 3929	Authorized officer MICHAEL HALL Telephone No : (02) 6283 2474
--	--

INTERNATIONAL SEARCH REPORT

International application No.

PCT/AU2004/000151

C (Continuation). DOCUMENTS CONSIDERED TO BE RELEVANT		
Category*	Citation of document, with indication, where appropriate, of the relevant passages	Relevant to claim No.
X	WO 2001/031072 A (PINCHES et al.) 3 May 2001 Pages 9-14, Figures 3, 4d, 5a	15-16, 30-32
X	WO 2001/018269 A (BILLITON INTELLECTUAL PROPERTY B.V.) 15 March 2001 Pages 10-25, Figure 3	15-16, 30-32
A	US 6036862 A (STOVER) 14 March 2000 Whole document	1-33

INTERNATIONAL SEARCH REPORT

Information on patent family members

International application No.

PCT/AU2004/000151

This Annex lists the known "A" publication level patent family members relating to the patent documents cited in the above-mentioned international search report. The Australian Patent Office is in no way liable for these particulars which are merely given for the purpose of information.

Patent Document Cited in Search Report	Patent Family Member		
AU 60837/90	NONE		
WO 0131072	AU 11078/01 ZA 200202427	BR 0015071	CA 2388990
WO 0118269	AU 23012/01 AU 68064/00 CA 2381157 CA 2383816 FI 20020428 WO 0118266 ZA 200201532 ZA 200201537	AU 68062/00 AU 68065/00 CA 2383812 CA 2383817 WO 0118262 WO 0118267 ZA 200201535 ZA 200201538	AU 68063/00 AU 73918/00 CA 2383815 FI 20020427 WO 0118263 WO 0118268 ZA 200201536
US 6036862	AU 17151/00 US 6660164	CA 2358970 WO 0134527	EP 1165448
END OF ANNEX			