



Australian Government
Rural Industries Research and
Development Corporation



RURAL INDUSTRIES
Research & Development Corporation

Sustainable Biomass Supply Chain for the Mallee Woody Crop Industry



JULY 2012

RIRDC Publication No. 12/O22



Australian Government

**Rural Industries Research and
Development Corporation**

Sustainable Biomass Supply Chain for the Mallee Woody Crop Industry

by Erik Schmidt, Rick Giles, Rod Davis, Craig Baillie, Troy Jensen, Gary Sandell, Chris Norris

July 2012

RIRDC Publication No. 12/022
RIRDC Project No. PRJ-005295

© 2012 Rural Industries Research and Development Corporation.
All rights reserved.

ISBN 978-1-74254-377-2
ISSN 1440-6845

Sustainable Biomass Supply Chain for the Mallee Woody Crop Industry
Publication No. 12/022
Project No. PRJ -005295

The information contained in this publication is intended for general use to assist public knowledge and discussion and to help improve the development of sustainable regions. You must not rely on any information contained in this publication without taking specialist advice relevant to your particular circumstances.

While reasonable care has been taken in preparing this publication to ensure that information is true and correct, the Commonwealth of Australia gives no assurance as to the accuracy of any information in this publication.

The Commonwealth of Australia, the Rural Industries Research and Development Corporation (RIRDC), the authors or contributors expressly disclaim, to the maximum extent permitted by law, all responsibility and liability to any person, arising directly or indirectly from any act or omission, or for any consequences of any such act or omission, made in reliance on the contents of this publication, whether or not caused by any negligence on the part of the Commonwealth of Australia, RIRDC, the authors or contributors.

The Commonwealth of Australia does not necessarily endorse the views in this publication.

This publication is copyright. Apart from any use as permitted under the *Copyright Act 1968*, all other rights are reserved. However, wide dissemination is encouraged. Requests and inquiries concerning reproduction and rights should be addressed to the RIRDC Publications Manager on phone 02 6271 4165.

Researcher Contact Details

Erik Schmidt
National Centre for Engineering in Agriculture
University of Southern Queensland
Z2 Building, West street
TOOWOOMBA QLD 4350

Email: erik.schmidt@usq.edu.au

In submitting this report, the researcher has agreed to RIRDC publishing this material in its edited form.

RIRDC Contact Details

Rural Industries Research and Development Corporation
Level 2, 15 National Circuit
BARTON ACT 2600

PO Box 4776
KINGSTON ACT 2604

Phone: 02 6271 4100
Fax: 02 6271 4199
Email: rirdc@rirdc.gov.au.
Web: <http://www.rirdc.gov.au>

Electronically published by RIRDC in July 2012
Print-on-demand by Union Offset Printing, Canberra at www.rirdc.gov.au
or phone 1300 634 313

Foreword

This report provides an assessment of the mallee woody crop supply chain, based on a comparative assessment with the sugar supply chain. The report will assist in developing a sustainable supply chain for the mallee industry and its stakeholders, including farmers, harvesting contractors, biomass processors, biomass markets as well as university, private and public sector industry representatives.

While the report is of particular relevance to the mallee industry of Western Australia, where mallee trees are an integral part of wheat cropping systems, the findings are also relevant to other mallee areas in New South Wales, Victoria, South Australia and Queensland.

The report contrasts the mallee and sugar supply chain and recommends improvements to the mallee woody crop supply chain, covering,

- Crop production
- Harvest and transport systems
- Products and processing requirements
- Industry and business structures
- Supply chain planning and management
- Supply chain modelling and economic considerations.

The project was funded from RIRDC Core Funds which are provided by the Australian Government. In-kind commitments were provided through the Future Farming Industries CRC and the University of Southern Queensland.

This report is an addition to RIRDC's diverse range of over 2000 research publications and it forms part of our Bioenergy, Bioproducts and Energy R&D program, which aims to meet Australia's research and development needs for the development of sustainable and profitable bioenergy and bioproducts industries.

Most of RIRDC's publications are available for viewing, free downloading or purchasing online at www.rirdc.gov.au. Purchases can also be made by phoning 1300 634 313.

Craig Burns
Managing Director
Rural Industries Research and Development Corporation

About the Authors

Erik Schmidt

Erik is Director of the National Centre for Engineering in Agriculture (NCEA) at the University of Southern Queensland and is responsible for leadership of research and commercialisation projects in Agricultural Engineering. The NCEA specialises in developing collaborative teams of private and public sector research individuals and organisations to provide industry focused solutions. Erik holds key research leadership roles including overall responsibility for delivery of NCEA projects and principal investigator on a number of national projects.

He has worked closely with the Australian Sugar Industry while employed as project engineer with BSES Ltd and the CSIRO where work focused on harvesting systems and adoption of new technologies. He was formerly Head of the Engineering at the South African Sugar Association responsible for planning, coordination and management of research and development projects. A component of this work included evaluation of cane supply systems and assessing the potential for improving mill area profitability by managing cane supply and harvesting systems.

Rick Giles

Rick is a Senior Project Coordinator with the Department of Environment and Conservation of Western Australia and he is principally involved in a project with the Future Farm Industries Cooperative Research Centre, which is developing a new concept tree harvester for the mallee supply chain. His work on the harvesting principle and the associated supply chain extends back to the late 1990s and the strategies employed in sugar industry supply chains have been a major influence upon this work since 1999. With the engagement of the FFI CRC in the harvester development project in 2007, the funding of the project by the WA Low Emissions Energy Development Fund, and the engagement in 2008 of Biosystems Engineering in Toowoomba, development of harvesting technology is now well advanced.

Rick's involvement in the mallee industry development began in 1993 as the first substantial mallee resources were being planted in the WA wheat belt. Prior to that time he worked in forest silviculture and plant water relations research.

Rod Davis

Rod is an Agricultural Engineer with over 20 years of experience in research and development projects across various agricultural production systems. Rod is currently principal consultant and Director of FSA Consulting. Rod's role within FSA Consulting includes project management, water, energy and Green House Gas research in intensive livestock industries and water resource management. From 1995 to 2004, Rod was a research engineer with the Farming Systems group, BSES Ltd. His primary role was to conduct research in the area of machine issues associated with the growing, harvesting and transport of sugarcane including: the conceptualisation, development, trialling and commercialisation of alternative component designs, measurement of machine loadings and environmental data through the development of real-time data acquisition and monitoring systems and the development of industry harvesting best practice guidelines.

Rod has extensive experience in project management, sugarcane production, harvesting and harvester design, mechanical component design and power hydraulic system as well as data acquisition systems.

Craig Baillie

Craig is an Agricultural Engineer who grew up on a cotton farm in the Emerald Irrigation Area of Central Queensland and is currently the Deputy Director of the NCEA. Craig's responsibilities include

business development (new projects), commercialisation / application of engineering technology, the development of training programs and research management.

His practical experience includes technical support to Australia's largest sugarcane farmer, Bundaberg Sugar Ltd. For Bundaberg Sugar Craig's work focused on the development of company farming operations including new infrastructure, machinery development, new technologies and innovative farming strategies. Farming strategies focused on minimum tillage, machine guidance (GPS) and alternative crops. Whilst with Bundaberg Sugar, Craig worked in irrigation research (CRC for Sustainable Sugar Production) and was seconded to the Bureau of Sugar Experiment Stations (BSES) as project and extension officer for the Rural Water Use Efficiency Initiative (RWUEI) in Sugar from 1999 to 2002. Craig was previously involved in the CRC for Irrigation Futures by coordinating the development of new research projects.

Troy Jensen

Troy is a Senior Research Fellow/Senior Lecturer with the National Centre for Engineering in Agriculture and the Faculty Engineering and Surveying, University of Southern Queensland, Toowoomba. He received his PhD degree in Engineering from USQ.

Applying engineering technologies to agriculture is something that Troy has been doing since he commenced work in 1987. Since this time, he has gained extensive applied research experience in such diverse areas as: agricultural machinery, animal and plant biosecurity, precision agriculture, remote sensing, controlled traffic farming, native grass seed harvesting and management, grain storage, horticultural mechanisation, and biomass reuse. His current research area focuses on the use of Precision Agriculture Technologies and is currently working on a project funded by the SRDC titled "A co-ordinated approach to Precision Agriculture RDE for the Australian Sugar Industry".

Gary Sandell

Gary has had thirteen years of research experience in harvesting and transport systems and is currently the Principal of Harvest Solutions, a commercial consulting company. Before working in his current role, Gary worked for BSES Ltd where he gained valuable experience in field trials, harvester optimisation and extension methodologies. Gary began to develop data logging systems and then worked with GPS systems to measure and record harvester performance. Gary has worked with collaborators such as CSR Ltd., NSW Sugar Milling Cooperative, CSIRO and others in projects examining the sugar entire value chain. Highlights during this period include sugar innovator of the year 2003, principal editor of the harvest best practice manual and writing and collaborating on various scientific papers. Following this Gary worked as a freelance consultant, trading as Harvest Solutions, for a further four years, building up an impressive client list focussing on supply chain management.

Chris Norris

Chris is a principal consultant with NorrisECT leading providers of innovation and technology for the growing energy crop industry with a strong focus on market development and strategic planning of the energy crop industry. Chris provides the company with an exclusive skill set and knowledge base that has gained him international recognition as a leading sugarcane technologist. Chris has over 35 years' experience in the innovation of agricultural mechanisation systems as well as an extensive understanding of agricultural processes that have been developed over decades of involvement in R&D projects. Chris has consulted globally through internationally recognised Booker-Tate Ltd and independently, developing specialist expertise relating to biomass recovery strategies for cogeneration.

Chris and NorrisECT have internationally recognised expertise in a number of areas including gathering and forward feeding of cane, optimisation of harvester and trash extraction system performance, load densification, transport logistics and factory based trash separation and biomass recovery strategies for cogeneration.

Acknowledgments

The authors would like to gratefully acknowledge the funding support from RIRDC that enabled this report to be prepared. We also acknowledge the advice provided by many people consulted in collecting information for the project. In particular we would like to acknowledge those individuals from the Future Farming Industries CRC, Western Australian Department of Environment Conservation, Oil Mallee Association, NSW Sugar Milling Cooperative and Aurora Research who participated in workshops and discussions. Special recognition is given to the Future Farming Industries CRC and Richard Sulman of BioSystems Engineering who are leading the harvester development program for their input, support and guidance.

Contents

- Foreword iii
- About the Authors iv
- Acknowledgments..... vi
- Executive Summary..... xii
- Introduction 1
- Objectives 3
- Methodology..... 4
- 1. Crop Production..... 6**
 - 1.1 Cropping System 6
 - 1.2 Crop Components and Uses 15
 - 1.3 Supply Areas 19
 - 1.4 Resource management..... 22
 - 1.5 Discussion and Recommendations 27
- 2. Harvesting Systems 29**
 - 2.1 Harvester Design 29
 - 2.2 Design Considerations..... 35
 - 2.3 Machine Performance..... 41
 - 2.4 Harvester Performance Monitoring..... 54
 - 2.5 Harvest and Transport Integration..... 59
 - 2.6 Harvesting Costs and Payment Structures..... 64
 - 2.7 System Improvements 73
 - 2.8 Discussion 74
 - 2.9 Recommendations 76
- 3. Transport and Storage Systems 77**
 - 3.1 System Overview 77
 - 3.2 Infield Equipment..... 78
 - 3.3 Road Transport..... 90
 - 3.4 Transport Performance 95
 - 3.5 Discussion 97
 - 3.6 Recommendations 98
- 4. Products, Processing and Impact on Supply Chain 99**
 - 4.1 Product Options and Supply Chain Implications: Sugarcane..... 99
 - 4.2 Product Options and Supply Chain Implications: Mallee 102
 - 4.3 Mallee Products and Conversion Technologies 105
 - 4.4 Mallee Products, Markets and Value..... 106
 - 4.5 Summary and Recommendations 117

5.	Industry and Business Structures	119
5.1	Overview	119
5.2	Institutional / Regulatory Framework	119
5.3	Ownership within the Supply Chain	124
5.4	Ownership and Implications.....	132
5.5	Suggested Industry and Business Structures for Mallee	133
5.6	Lessons for the Mallee industry from Sugar	133
6.	Supply Chain Planning and Management	135
6.1	Drivers of Supply Chain Efficiency	135
6.2	Integration Across the Supply Chain.....	138
6.3	Coordination and Collaboration	139
6.4	Planning, Management Tools and Modelling	143
6.5	Models for Supply Chain Planning and Management - Examples for Sugarcane	144
6.6	Supply Chain Alternatives and Options for the Mallee Industry	149
7.	Supply Chain Modelling and Economic Considerations	152
7.1	The Harvest-Haul Model.....	152
7.2	Component Costs to Supply Chain	153
7.3	Costing Assumptions.....	153
7.4	Sensitivity Analyses	159
7.5	Conclusion and Recommendations	163
8.	Conclusions and Recommendations	165
	Appendix 1: Comparative Assessment with Sugarcane Supply Chain	174
	References	181

Tables

Table 1.1	Mallee species used for plantings in WA (source Oil Mallee Association)	9
Table 1.2	The changing harvest cycle length due to configuration and climatic conditions.....	11
Table 1.3	Establishment and management costs for contract operations	13
Table 1.4	Potential uses of mallee.....	18
Table 1.5(a)	Land area devoted to cropping and pasture in Southern Australia.....	20
Table 1.5(b)	Mean annual increment to harvestable size ¹ of mallees growing in two row belts for each rainfall zone	21
Table 1.5(c)	Potential annual biomass production for mallees growing in two row belts, by rainfall zone	21
Table 2.1	Harvester Comparison Table.....	41
Table 2.2	Cane supply composition (wet and dry matter basis).....	46
Table 2.3	Bulk density of cane supply	48
Table 2.4	EM levels in cane supply	51
Table 2.5	Effect of yield on harvester fuel use	53
Table 2.6	Harvester performance comparison	53
Table 2.7	Typical cane losses during harvesting	54
Table 2.9	Field efficiency for Australian harvesting	58
Table 2.10	Harvester performance monitoring comparison.....	59
Table 2.11	Alternative harvest payment systems options, consequences and incentives	66
Table 2.12	Cost of sugarcane harvesting	69
Table 2.13	Typical costs of sugarcane harvesting	69
Table 2.14	Estimated costs of mallee harvesting, excluding profit and tax	72
Table 3.1	Sugarcane haulout equipment manufacturers.....	82
Table 3.2	Examples of sugarcane haulout capacity	84
Table 3.3	Haulage vehicle load/gross mass ratio	85
Table 3.4	Effect of haul distance on haulout fuel use	87
Table 3.5	Costs of road transport of mallee biomass with side loading and unloading	94
Table 4.1	Typical composition of mallee at harvest size	102
Table 4.2	Assessment of current value and annual production and potential production and possible impact on product value.	107
Table 4.3	Value of feedstock components for Mallee Oil for boutique and industrial use	109
Table 4.4	Value of feedstock components for activated charcoal.....	110
Table 4.5	Value of feedstock components for Metallurgical Charcoal.....	110
Table 4.6	Value of feedstock components for Bio-Char for various uses.....	111
Table 4.7	Value of feedstock components for the manufacture of Synthetic Diesel.....	112
Table 4.8	Value of Mallee as a feedstock for local small-scale thermal applications.....	113
Table 4.9	Value of Mallee woodchip for electricity generation.....	114
Table 4.10	Summary of value of recoverable/deliverable components.	116
Table 5.1	Ownership of Australian sugar mills.....	128

Table 6.1	Examples of the processes that have been modelled within the different sectors of the Australian sugar industry	145
Table 7.1	Scenario one capital equipment.....	155
Table 7.2	Scenario two capital equipment.....	156
Table 7.3	Scenario three capital equipment.....	157
Table 7.4	Fuel burn rates	158
Table 7.5	Data table of the effect of harvester pour rate and annual tonnes on the cost of harvest.....	163
Table 7.6	Effect of harvester pour rate and annual tonnes harvested on shift length.	163
Table 7.7	Comparison of Mallee (Western Australia) and Sugarcane (Whole crop - NSW) harvesting costs.....	164

Figures

Figure 1.1	The cropping and pasture land in the 300-600 mm mean annual rainfall zones of WA (top) and south eastern Australia (bottom).....	7
Figure 1.2	The cane growing regions on the NE seaboard of Australia	8
Figure 1.3	Two row alley farming on the contour near Trayning WA.....	10
Figure 1.4	The mallee belt system integrated with agriculture.....	14
Figure 1.5	Six year old <i>E. loxophleba</i> subsp. <i>Lissophloia</i>	17
Figure 2.1	Layout of Australian standard ‘chopped cane’ sugarcane harvester	30
Figure 2.2	Biosystems Engineering prototype woody crop harvester	31
Figure 2.3	Ex-harvester mallee biomass (left) and after screening (right).	34
Figure 2.4	Wheel spacing 1.5 m row spacing – 1.85 m wheel spacing	36
Figure 2.5	Wheel spacing: 1.85 m wheel spacing - dual row	36
Figure 2.6	The top of a mallee lignotuber removed by the harvester’s saw (above) and the condition of the site with cleanly cut stumps after passage of the harvester (right).....	43
Figure 2.7	Effect of crop size on maximum harvester (tracked machines) delivery rate in burnt and green cane.....	45
Figure 2.8	Bulk densities of whole-cane	47
Figure 2.9	Loading a chip truck with mallee biomass using a roadside chipper	48
Table 2.8	Field efficiency for various crop sizes (Willcox, 2004)	57
Figure 2.10	GPS harvester tracks in a harvested field, coloured by speed	61
Figure 2.11	Effect of group size on harvesting costs	70
Figure 2.12	Effect of crop yield on harvesting costs	70
Figure 2.13	Effect of row length on cost of harvesting	71
Figure 2.14	The effect of harvester pour rate and annual tonnage per harvester upon cost of biomass harvested and delivered to field edge.....	72
Figure 3.1	Tractor drawn side tipper	80
Figure 3.2	Tractor drawn trailer with end lift and cross-elevator unload	80
Figure 3.3	Articulated self-propelled with end lift and cross elevator unload.....	81
Figure 3.4	Tracked rigid self-propelled with side tipper.....	81
Figure 3.5	Self-propelled with side tipper (power haul).....	82

Figure 3.6	Conceptual haulout configuration with a 70 m ³ bin	83
Figure 3.7	Gross mass compared with load and tare weight of haulout vehicles in the sugar industry	85
Figure 3.8	Effect of haulout speed on infield transport cost.....	86
Figure 3.9	Effect of haul distance on infield transport cost.....	86
Figure 3.10	Haulout and harvester fuel use (Sandell and Agnew 2002)	88
Figure 3.11	The effect of haulout travel speed and bin size on infield transport costs	89
Figure 3.12	The effect of transport distance and harvester pour rate on infield transport costs	89
Figure 3.13	Multi-lift semi-trailer bin	91
Figure 3.14	Fliegl Gigant push-off trailer	91
Figure 3.15	Standard two trailer chip transport with rear tipping trailers	93
Figure 4.1	Trash recovery for cogeneration in Brazil by baling the trash after machine harvesting.....	101
Figure 4.2	Trash recovery from integrated trash and cane delivery in a large sugarmill in Brazil.....	101
Figure 4.3	System in Brazil for separating trash on the harvester and transporting it separately to the mill.	104
Figure 4.4	Attachments are available for choppers and forage harvesters to remove a proportion of the leaf and lighter material.....	104
Figure 4.5(a)	Mass balance of biomass conversion using fast pyrolysis.	105
Figure 4.5(b)	Energy balance of conversion of biomass using fast pyrolysis.	106
Figure 5.1	Cane supply chain (source Jones, 2004)	125
Figure 6.1	Building blocks of the supply chain	137
Figure 6.2	Cooperation requirement for value chains	142
Figure 7.1	Rear-tip trailer	154
Figure 7.2	Side-tip trailer	155
Figure 7.3	Swing-lift containers	157
Figure 7.4	Impact of haulage distance on road transport costs.....	159
Figure 7.5	Effect of capital equipment selection and cost on harvesting cost.	160
Figure 7.6	Effect of belt spacing an cost of harvest	160
Figure 7.7	Effect of annual tonnes harvested on harvesting cost	161
Figure 7.8	Effect harvester pour rate on harvesting cost	162
Figure 7.9	Effect of harvester pour rate and annual tonnes harvested on the cost of harvest.....	162

Executive Summary

What the report is about

This report provides a pre-feasibility assessment of the mallee woody crop supply chain based on a comparative assessment with the sugar supply chain. The report will assist in developing a sustainable supply chain for the mallee industry. The report covers the supply of material from the field to potential processing facilities and discusses potential mallee products and markets, business and commercial structures, and supply chain planning and management required to support this delivery chain.

Who is the report targeted at?

The report is targeted at the stakeholders of the mallee woody crop industry. Stakeholders include:

- Seedling nurseries and contract tree planters
- Farmers
- Harvesting contractors
- Road transport operators
- Biomass processors and conversion industries
- Consumers of the products from conversion industries
- CRC, university and public sector industry development workers
- Private sector industry development individuals and corporations other than farmers

The report is of particular relevance to the mallee industry of Western Australia where mallee trees are an integral part of wheat cropping systems. The findings are also relevant to other mallee areas in South Australia, New South Wales, Victoria and Queensland where production is focussed on biomass production, and is not integrated with other cropping systems. The principles and approach of this study could also be applied to other biomass supply chains.

Background

Short cycle tree crops, such as mallees have the potential to play an important role in the long-term sustainability of low rainfall agriculture. The economic sustainability of the mallee industry depends upon developing markets and industries to utilise the biomass. A fundamental part of this development is the biomass supply chain, the system which links the crop in the farm paddock to the processing factory.

Significant research and development, has to date, focussed on the development of processing facilities for mallee oil, and mallee harvesting systems. Only limited formal consideration has been given to the complete biomass supply chain, from field to factory.

This project has undertaken a pre-feasibility assessment of the mallee supply chain, industry structure and potential markets and products, with an aim to optimise the supply of material from the field to the processor. The Australian sugarcane industry is a large biomass supply chain, and therefore has synergies with a mallee biomass system. Therefore, it offered a compelling opportunity to inform the mallee industry based on similar supply challenges and 100 years of experience.

Project investigations relate primarily to the mallee woody crop industry in Western Australia and pertain both to existing harvesting systems being developed under the Future Farming Industries CRC programs, as well as for expanded production capacity. The principles and approach of this study could also be applied to other biomass sources and regions.

Aims/objectives

The objective of this study was to provide a comparative assessment of the mallee and sugarcane supply chain. Comparative analysis with a mature industry such as the sugar industry, which has many similarities to the mallee industry, will help guide the development of a sustainable biomass supply chain for the mallee industry.

The specific objectives of the project were to:

- Identify the mistakes and lessons learnt by the sugar industry relevant to material supply in the mallee industry.
- Review the material harvest, handling and processing requirements for a sustainable mallee biomass industry.
- Investigate tools, processes and models used in similar biomass industries (sugar) which are potentially applicable to the mallee industry.
- Develop a conceptual framework to assess harvest/supply issues.
- Identify commercial and business structures that have been effective in the sugar industry and are relevant to the mallee industry.
- Undertake a desktop assessment of the logistics for mallee supply.
- Identify critical elements, gaps and opportunities for further development of a sustainable mallee industry.
- Determine key performance criteria for components within the harvest supply chain.

Methods used

The project was undertaken in the following stages:

1. Data collection and review (mallee industry and comparative sugar industry).
2. Identify and outline the key issues, and develop discussion paper and analysis framework.
3. Consultation, discussions and workshops between project team, mallee industry and stakeholders.
4. Analysis and assessment including assessment of supply chain and business drivers, identification of gaps, opportunities and requirements.
5. Mallee industry delegation visit to the NSW sugar industry, and formal workshop to discuss and benchmark supply issues.
6. Final reporting and recommendations.

Results

This study has provided an assessment of the biomass supply chain for the mallee woody crop and sugar industry. While the supply chain for these commodities has many similarities, there are also stark contrasts. Key differences and contrasts are summarised below.

Crop-Biomass Production

- The sugar industry has evolved to maximise profitability and sustainability in a market driven industry. Mallee plantings were initiated in Western Australia to control salinity while generating some profit. More recently the emphasis upon mallees as an alternative enterprise on a small proportion of the farm has become the equal or predominant driver, while environmental drivers remain a significant factor in some regions.
- The sugar growing system is structured around maximum sugarcane production and reduced harvesting and transport costs. The Mallee system in Western Australia is structured around wheat production, and layouts are not efficient from a harvest and transport perspective.
- Biomass production potential of mallee (2-6t/ field ha) is very low when compared with sugar (80-150t/ha). This has an impact on vehicle utilisation and efficiencies.

- Sugarcane has to be harvested at optimum age and quality whereas the value of mallee product does not change significantly. Mallee, thus, has less risk attached to harvest date.
- Traditional mallee field layouts comprising long alley lengths, result in varying haul distance to the loading pad which complicates infield haulage.

Harvesting, transport and storage systems

- High average sugarcane harvester throughputs of 100 to 150 tonne/hr are generally achievable, versus 20-40 tonne/hr for the current prototype mallee harvester, and an objective of 60-80 tonne/hr for subsequent prototypes.
- Sugarcane harvester field efficiencies (time spent harvesting as a fraction of the total harvest time) are typically 30% to 50%. Efficiencies for mallee are anticipated to be much higher, 70-80%, due to long belt lengths and low harvesting speeds reducing the number of times the harvester needs to turn per hour.
- Sugar cane harvesting operations will typically deliver 50 to 60 tonne/hr (harvester pour rate by field efficiency), versus 20 to 40 tonne/hr for mallee. Low delivery rates result in higher costs of harvesting given the general relativity in anticipated cost of equipment required in the harvesting operation.
- Mallee biomass infield transport is also expected to be greater than for sugar cane, due to the larger paddocks and more dispersed resource.
- While bulk density data is limited, initial studies and experience in the WA wood chip industry suggest that it is possible to achieve legal axle loads when utilising relatively standard transport equipment. Thus, bulk density should not be of great concern to the mallee industry, with some limitations.
- Mallee biomass is generally more difficult to move, tip and transport than clean sugarcane billets, based on its varied leaf, stick and chip in delivered material. This makes it desirable to minimise the degree of transloading of the product during its progress from the harvester to the point of initial processing.
- Separation on the harvester of leaf and chip will result in product losses in field. This is impacted by the product required to be delivered to the processor, which will depend on whether there is a market for all products, especially the leaf.
- Greater reliability of biomass supply results in lower balancing storage. In the sugar industry there are multiple suppliers, and generally, storage in rail bins, which helps balance supply. For the mallee industry, stockpiles at the processing plant will be important. Processors operate 20 to 24 hours per day, seven days per week and 300 to 365 days per year. Harvest activities occur during daylight hours and breaks for servicing are required. Initially, with a single harvester and limited number of transport units, reliability will be low, adding to the requirement of stockpiles. Storage life of material in stockpiles will be important
- Given long road transport distances are likely and low value of the delivered mallee biomass, savings through full utilisation, maximum payload and quick turn-around time will be a pre-requisite, as is found in sugar industry road transport systems.

Industry and Business Structures

- It will be difficult to get integration along a fragmented mallee supply chain unless key participants (eg the processor or a transport contractor) see the supply chain as core business. The sugar industry supply chain developed around regulation and rules to manage risk. Recent deregulation of sugar supply contracts has been based on an existing viable business structure. The distributed ownership of the sugar supply chain has resulted in inherent inefficiencies at the ownership interfaces.
- The mallee biomass industry has opportunity to implement new optimised supply chain arrangements rather than optimising existing structures as was required in the sugar industry.

- Harvest scheduling may not be as critical for mallee biomass since harvest to process delays will not compromise quality as much as in sugar, and short term stockpiling is possible, however further research on storage losses is required.
- Harvesting and transport costs are likely to be at the growers' expense, either directly when a contractor is engaged by the farmers, or indirectly when the biomass value is determined by the biomass processor, who engages the harvest and transport contractor, and pays the farmers an amount for the standing mallee.
- Mallee biomass processor companies are unlikely to be as engaged with crop production, harvesting and transport matters as sugar millers are in cane.
- Multiple product streams from mallee biomass will introduce complexity into supply chain management requirements.

Biomass processing, supply chain planning and economic and market consideration

- Sugar mills have developed sophisticated sugar extraction processing capability over many years. New by-products and processing requirements are in many cases complementary to sugar extraction technologies.
- The development of a viable industry based on mallee biomass cannot happen overnight, or on the back of current products such as the boutique oil industry. A number of local options exist, which can offer very attractive markets for limited production quantities. Such markets include local thermal for abattoirs and feed milling, and local electricity, particularly for use by local industry where the cost of supply of sufficient capacity from the grid would be prohibitive. As the industry expands, most significant potential market will probably involve emerging technologies such as liquid fuels via pyrolysis.
- The sugar value chain is well developed and has committed stakeholders who are fully dependant on one another. The bioenergy value chain is less developed and has competing supply products.
- The sugar miller has a good understanding of the producer's needs, and many sugar millers also have sugarcane growing operations which are used to manage supply risk, particularly early in the harvest season when sucrose values are low and farmers are generally unwilling to supply cane.
- Energy markets will generally see the biomass supply as a commodity, and have no interest in becoming involved in supply chain planning and management.
- The sugar industry growing sectors have some influence on price paid for cane (through their representing bodies (Canegrowers)) and in some regions are rewarded through the pricing mechanism for good quality cane.
- In the mallee industry producers are likely to be price takers in the electrical energy market where price is determined by substitute products. In thermal energy markets, LPG is the preferred energy source due to high electrical transmission costs and poor conversion to heat energy. While these markets are more localised and moderate in size, larger margins in the thermal market allow mallee suppliers more room for negotiation.
- There is no trading commercial representation of mallee producer interests. A mechanism to establish a market related price accounting for quality of mallee biomass will be important.
- Better economies of scale are required for the mallee biomass industry through appropriate business structures, such as cooperatives, joint ventures and consortia.

Implications for relevant stakeholders

Important overall implications include:

- The development of a long term viable mallee biomass industry can be driven by actively targeting small but potentially highly profitable niche markets in the short term, and supporting these to further develop the technology envisaged for a larger scale industry.
- As the Industry expands, the most significant potential markets will probably involve emerging technologies such as liquid fuels, via pyrolysis. Initial processing and oil extraction could be undertaken at nodal points, with "value added" product forwarded to the major centres.

- Apart from continuing development of harvesting technology, the components in a full scale industry must be further developed. This will involve further analysis of potential product streams and the opportunities for maximising the synergies from the production of different products.
- Block plantings close to a processor will be important for large scale industry development.
- Mallee harvesting and transport costs are expected to be 3-4 times that for sugarcane. With increased production volumes and higher delivery rates this could drop to twice that of current sugarcane harvesting and transport costs. New field layouts and increased harvester performance need to be considered to reduce these costs.
- There is a need for an intermediate entity to occupy the space between the grower and processor and make a business of a profitable supply chain. Neither the grower nor the processor has a real interest in the supply chain.
- Long term contracts will be required to guarantee supply and attract appropriate investment in biomass production.
- Accurate information on the distribution and availability of biomass material will need to be collated and maintained.

These implications are discussed in greater detail in the recommendations below.

Recommendations

The participants in the mallee woody crop supply chain are many and varied. The key issues and recommendations provided in this report will assist all participants in realising a sustainable supply chain. An important next step will be implementation of appropriate recommendations to support implementation of a regional biomass supply chain. Opportunities for this include Narrogin, NSW as part of the Delta/Aurora research biomass project, and Northern NSW as part of the NSW Sugar Milling cooperatives cogeneration initiative.

Key Issues and recommendations are identified below.

Crop-biomass production

- There is greater incentive in the sugar industry to integrate the supply chain with the key driver being enterprise profitability. Returns from mallee production in Western Australia are generally seen as secondary to the core business of wheat production and marginal, so there is less incentive to optimise.
- Changes to mallee farming systems are therefore unlikely, while wheat production remains the main economic driver. The only changes are likely to be in frequency of harvesting.
- Consideration has been given to alternative mallee field layouts. Economic modelling has been undertaken to evaluate the most effective cropping of mallee and wheat, accounting for yield versus moisture competition. Changes to recommended configuration are unlikely in integrated plantings.
- Consideration needs to be given to alternative denser mallee plantings in narrower alleys (10-30m) on marginal land (ie without annual crops in the alleys), close to the processor, to supplement existing and future mallee plantings that are wide-spaced belts integrated with annual cropping.
- Such block plantings close to a processor will be important for large scale industry development. Planting would need to be in row configuration to improve harvesting efficiency with row spacing established to minimise suppressed growth due to competition.
- Harvest efficiency will be maximised when the concentration of biomass per metre of row is maximised, and distance between rows is minimised. Impact of spacing on moisture competition is, however, critical when determining optimum configuration.
- Unlike what has occurred in Western Australia, future expansion in mallee production will be driven by the market for biomass, and farming systems and layouts will need to adapt to the economics of this supply arrangement.
- Sophisticated information and data collection systems have been developed in the sugar industry to manage supply areas and volumes, which can be readily customised for biomass industries.
- Consideration will need to be given to protocols for carbon credits under the carbon farming initiative.
- In Western Australia, mallee planting provides vegetative biodiversity in a wheat monoculture, and the collateral benefits of this biodiversity and associated environmental dividend needs to be quantified.

Harvesting, transport and storage systems

- Mallee harvesting costs are expected to be 3-4 times that for sugarcane. With increased production volumes and higher delivery rates this could drop to twice current sugarcane harvesting costs. New field layouts and increased harvester performance need to be considered to reduce these costs.
- Harvester pour rate has the largest impact on the cost of harvest and transport. Current trials provide opportunities to optimise harvest performance, and collect appropriate information on fuel consumption, vehicle utilisation, harvester location, power and pressure and material flow, bulk density etc. This should include the matching of power in different parts of the harvester.
- Bulk density changes with tipping and transport and associated impact on product handling needs to be assessed. Consideration will need to be given to appropriate tipping and pouring options. Harvester and chipper design could be impacted in terms of chip size and the trade-off between chipping costs (chip size) and transport costs (packing and bulk density).
- Consideration will need to be given to ways to improve field efficiencies. This could inform changes to the mallee row arrangement to better suit commercial harvester and transport constraints. Harvester operation and production appears optimised if mallees are close together (<2m intra-row spacing) in +3m spaced rows.
- Haulout efficiency will be maximised if production per paddock hectare is maximised, and haul distances to the road landing are reduced.
- The lowest cost system occurs when trailers or bins are taken directly from the harvester to the nearest trafficable road, and left for transfer to road transport to haul direct to the processor and return to the field for re-use.
- Where infield transport distances are large and pour rates are high, a two stage hauling out using two paddock haulouts and a high speed “shunt” may need to be considered.
- Harvest and transport systems will be impacted by the nature of the material to be delivered (eg chips vs leaf material) which is impacted by the product stream (eg bioenergy vs mallee oil).
- Consideration should be given to pre-processing at local nodes eg pelleting, leaf separation. However costs and efficiencies would need to be assessed.
- Short term stockpiles are likely to be essential between the harvester and road transport. This is likely to be in the form of trailers stored at the road landing or bins that can be self-loaded onto the trailer. Infield loading of road transport will be limited by field access and year round soil/field conditions.
- Stockpiles at the processor will be required to balance supply with processor demand and the composition of the product in the stockpiles may significantly impact on storage life.
- The current harvesting system is limited by available power, which impacts pour rate, a critical factor in the delivered biomass cost, and future prototypes will need to address this.
- Transport efficiencies may be improved by leaving residue materials such as bark and twigs behind in the paddock, however, separation on the harvester will result in a more complex machine design and high product losses in field.
- Annual tonnage harvested also has a large effect on the cost of harvest.

Industry and business structures

- A range of supply chain ownership models are possible. Generally the greater the proportions of the supply chain owned by a single entity, the greater the efficiency and lower the conflict. Good performance across the supply chain also results when there is cooperation and commitment between each sector in sharing business proceeds.
- It will be important for organizations involved in the mallee supply chain to discuss and outline their vision and requirements.
- The mallee industry has new opportunities to put in place appropriate supply arrangements. These need to address the likely imbalance between the processor (established and powerful, potentially with alternative supply options) and the grower.
- An intermediate commercial entity will need to occupy the space between the grower and processor and make a business of a profitable supply chain. Neither the grower nor the processor is likely to have a real interest in the supply chain.
- Consideration needs to be given to the need for a growers' commercial representative, similar to the role of the former Oil Mallee Company.
- Streamlining harvest and transport costs will require coordination at the processing end to meet supply requirements. A single operator for harvesting and transport would most likely evolve to provide scale and economic benefits.
- Seasonal mallee supply will need to be accurately determined to manage harvesting and processing, although daily scheduling may not be as sensitive as it is in the sugar industry.
- Industry development will be driven by the party who values the product most. The processor will need to take an interest in farm based production issues to ensure a sustainable supply source, even though they are unlikely to be interested in biomass growth.
- Long term contracts will be required to guarantee supply and attract farmers to grow the biomass.
- Payment systems and business structures vary in sugar cane and provide a range of models from which the mallee industry will be able to choose. A payment formula that accounts for quality of material delivered will be important when there are multiple products and markets. Contract specific pricing arrangements would be required.

Biomass processing, supply chain planning and economic and market consideration

- Development of a viable mallee biomass industry will take time. A number of “local” processor options exist which can offer attractive markets for limited production quantities (eg local thermal and electricity solutions). As the industry expands, most significant potential market will probably involve emerging technologies such as liquid fuels via pyrolysis.
- A potential strategy for expanding the industry could comprise harvesting the mallee trees utilising “short haul” transport concepts to transport the product 20-30 km from farms to nodal processing sites. Activities at the processing sites include:
 1. Separation of leaf, twig and bark material from the chipped wood at the processing site and extraction of oil using low technology steam extraction could occur.
 2. Low tech drying of the leaf for baling and use in local thermal or electricity production.
 3. Transportation of the woodchip via rail or road to appropriate processing facilities.
- Preliminary analysis of potential mallee products, including the feedstock component, product value and extraction costs, suggests that fresh weight values in the order of \$100/t could be achievable for large scale oil extraction combined with metallurgical charcoal and potentially synthesised diesel. Similarly, for a limited local industry comprising oil extraction combined with local electricity and thermal heat, fresh weight tree value could be in the order of \$185/t. Processor profit margin is not included in these figures.
- This can be compared with harvest and haul costs (excluding contractor profits) of around \$45/t (based on small scale production of 15,000 t/yr, low harvester performance, pour rates of 30t/hr, and a 100km haul) and \$28/t (based on large scale production (145,000t/yr and high harvester performance, pour rate 50t/hr, and a 100km haul). Stumpage fees may be payable to the mallee grower to recover production costs, and could range from \$15-\$30/t
- Energy markets are less likely to be proactive in developing alternative resource streams to their existing sources. New businesses will need to develop to take up these other energy market opportunities. There are no other players in this space which are analogous to the sugar miller, with the possible exception of Delta Energy.
- Key barriers to biomass markets are likely to include:
 1. Marginal economics under current policy settings.
 2. Inadequate volumes in biomass production.
 3. Lack of integrated supply chain.
 4. Uncertainty in volume of resource available.
 5. Lack of established market for mallee biomass.
 6. Limited interest in biomass supply within agricultural sector and electricity generating sector.
- The economic viability of mallee for bioenergy production is better suited to thermal energy production and less to electricity generation given processing efficiencies.
- New markets will be required for mallee biomass. This could involve a business who pre-processes the biomass (analogous to a sugar mill), separating the various components (eg trash, leaves, chips) for separate processing of oil, charcoal, bio-oil, electricity generation (analogous to the sugar refinery).
- An energy market or regulatory mechanism to increase the mallee biomass price may be required.
- Alternative markets for different parts of the biomass (e.g. woodchips, leaf, twigs) will require further processing (eg separation, pelleting) with associated costs. Beneficial income would need to exceed incremental processing costs. While diversification can add value to the industry, the impact on supply chain constraints needs consideration.
- Multiple markets will also increase focus on quality of material supplied.
- Uncertainty in the market and future pricing would negate a processor negotiating long term supply contracts.
- It will be unlikely for a processor to invest in biomass supply unless there is an established market that could be made more secure by investment in the supply chain.
- There are both tangible and intangible benefits of value chain improvement that need to be communicated to stakeholders.
- Flexibility is essential in biomass supply chains to cope with and adapt to unforeseen events.

Introduction

Short cycle mallee tree crops have the potential to play an important role in the long-term environmental and production sustainability of low rainfall agriculture. The economic opportunities for the mallee industry depend upon developing markets and industries to utilise the biomass.

A fundamental part of this development is the biomass supply chain, the system which links the crop in the farm paddock to the processing factory. Significant research and development has to date focussed on the development of processing facilities for mallee and mallee harvesting systems. Limited consideration has been given to the complete biomass supply chain, from field to factory.

It is important that the supply chain is not only seen as synchronising equipment and processes for material handling. Equally important is the addition and distribution of value to all stakeholders, collaboration and information sharing and development of a common vision by all parties. While systems assessment and logistic modelling can provide guidance on improvements to the supply chain, this has not always been effective in the sugar industry where there has not been broad stakeholder engagement.

A broad assessment of the mallee supply chain and industry structure has been undertaken in this project using the Australian sugarcane supply chain as a basis for comparison. The sugar industry has been operating over 100 years as a large biomass supply chain and provides a compelling opportunity for a comparative analysis. By reviewing the plant production, harvesting, transport, storage and processing components of each industry, as well as industry and business structures and supply chain planning and management approaches, key similarities and differences have been identified.

While a potential market for biomass products for electricity supply is emerging, the agronomic, harvesting and transport processes require greater consideration and potentially a paradigm shift to reduce supply costs to affordable levels. Alternatively new products and markets may be required.

A number of key areas need to be considered to improve mallee supply chains:

- **Planting and field layouts**

Mallee planting configurations need to support efficient harvest and transport systems. Age at harvest, spacing and row length will all impact harvester pour rate and efficiency. Field layout will also impact mallee and adjacent crop moisture competition and production.

- **Harvesting, transport and storage systems**

Harvesting costs will reduce as production volume, supply per hectare and machine delivery rates increase and haul distances are reduced. The proportion of chip, leaf and twigs in delivered material will impact bulk density, transport efficiency, tipping and pouring. The value of biomass to the processor will also be impacted by material composition.

- **Industry and Business Structures**

It will be important for all stakeholders to be involved in supply chain planning and management. An imbalance of power between the processor and growers could impact the supply chain. Farmers will only adopt mallee as a crop if their market position is recognised and returns from mallee are justified and are similar to current land use.

- **Economic and market considerations**

Key barriers to biomass industries include the marginal economics under current policy settings, low volumes of biomass and lack of an integrated supply chain. There is also uncertainty in the

volume of resource available and no established market for mallee biomass exists. There are a number of potential product streams, including electricity generation, fuel pellets, thermal energy, charcoal, eucalyptus oil and bio-fuels. Market price, production volumes and processing costs will affect viability.

While there is likely to be increased focus on commercial markets for multiple products produced from mallees, impediments for development of the industry include lack of economically viable technologies and markets associated with processing of mallees, and insufficient scale for a viable industry (URS 2008).

Significant recent work has been undertaken to investigate harvest and transport systems and costs for the mallee industry. The sugarcane industry has faced similar problems and challenges in developing an efficient harvest and transport system for its high biomass product over a hundred years. This report provides opportunities for the mallee industry to learn lessons from the sugar industry.

Objectives

An important part of the development of the mallee woody crops industry will be to ensure optimised and synchronised supply of material from the field to the processing facility. This would reduce the costs of harvesting and hauling biomass, and would maximise farmer and processor returns.

The objective of this study was to provide a comparative assessment of the mallee and sugarcane supply chain. Comparative analysis with a mature industry such as the sugar industry, which has many similarities to the mallee industry, can inform the development of a sustainable biomass supply chain for the mallee industry.

Consideration was given to how components of the harvest / delivery system are impacted by the source of mallee material (volume, location, quality, and harvest window), the market and product options, supply chain implications and industry and business structures. Systems assessment and modelling was undertaken to allow sensitivity analysis of changes to components in the harvest/supply system on harvesting economics and efficiencies.

The specific objectives of the project were to:

- Identify the mistakes and lessons learnt by comparative industries (e.g. sugar) relevant to material supply in the mallee industry.
- Review the material harvest, handling and processing requirements for a sustainable mallee biomass industry.
- Investigate tools, processes and models used in similar biomass industries (e.g. sugar) which are potentially applicable to the mallee industry.
- Develop a conceptual framework to assess harvest/supply issues.
- Identify commercial and business structures that have been effective in the sugar industry and are relevant to the mallee industry.
- Undertake a desktop assessment of the logistics for mallee supply.
- Identify critical elements, gaps and opportunities for further development of a sustainable mallee industry.
- Determine key performance criteria for components within the harvest supply chain.

Methodology

The project was undertaken in the following stages:

1. Data collection and review (Mallee industry and comparative sugar industry).
2. Identify and outline the key issues and develop discussion paper and analysis framework.
3. Consultation, discussions and workshops between project team, mallee industry and stakeholders.
4. Analysis and assessment including assessment of supply chain and business drivers, identification of gaps, opportunities and requirements.
5. Mallee delegation visit to the NSW sugar industry and formal workshop to discuss and benchmark supply issues.
6. Final reporting and recommendations.

The design and scope of the project was structured around the framework illustrated in the flow chart below, which illustrates elements of the supply chain and informs the structure of this report.

Initially an assessment was undertaken of mallee production systems and contrasts with sugarcane production. Crop growth cycle, field layout, crop management, yield and supply areas impact the efficiency and economics of biomass harvesting operations. It is important that an accurate resource inventory of biomass supply exists to assess supply volumes and constraints. Changes to field layout and age at harvest can have significant impacts on harvest efficiency.

Consideration was given to harvesting, transport and storage systems for both mallee and sugarcane. Mallee harvester design and capability will be important to improve throughput, losses, product quality issues, and harvesting economics. Transport and storage systems will impact infield and long-haul transport requirements. Trailer size and configuration as well as product bulk density and payload will impact supply chain economics and system performance. Storage will impact handling costs and quality changes to biomass material (eg moisture content).

Biomass products and processing options will also impact the supply chain. A number of product options have evolved for sugarcane and exist for mallee. Potential mallee products will be impacted by market price, production volumes and conversion efficiencies. This will in turn impact the best approach for material harvesting and handling.

Industry and business structures have played a major role in the evolution of the sugar industry and the ability of regions to adopt best supply chain management practices. Ownership within the supply chain and payment systems all impact the supply chain and consideration has been given to developments in the sugar sector that may have relevance to mallee.

Integration along the supply chain through material supply planning and logistics management, information collection and system modelling has been effective in improving the logistics of the sugar supply chain and consideration has been given to approaches that may have relevance to mallee systems.

Finally consideration has been given to component costs of the supply chain and harvest-haul operation pricing using appropriate costing models. Of particular importance is the sensitivity of the delivered cost of biomass per green tonne based on key drivers such as harvester pour rate and production volumes.

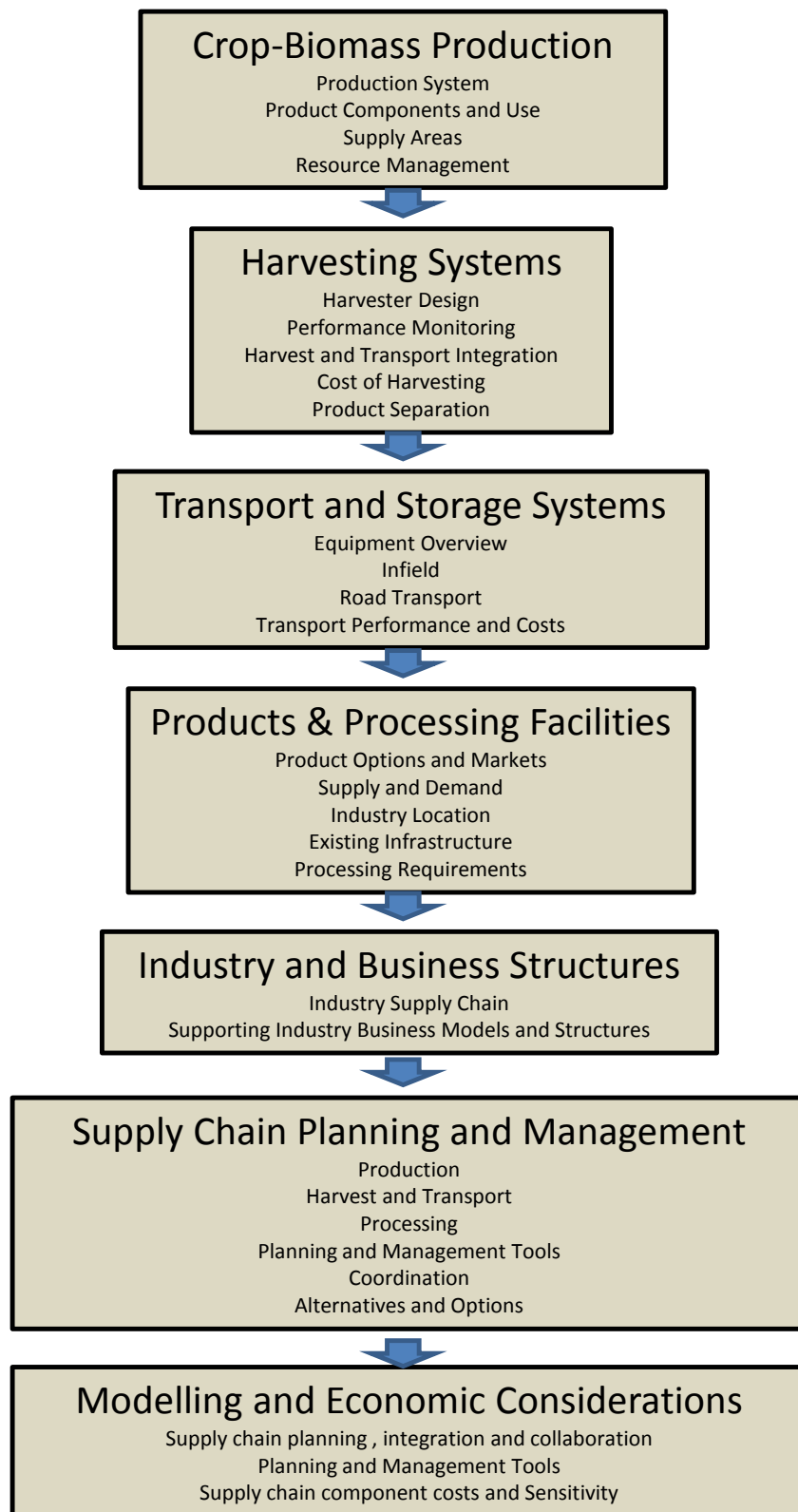

Analysis framework for mallee supply chain.

1. Crop Production

This section looks at the reasons that there is a mallee resource in Australia and investigates the various crop production systems that are currently being utilised, predominantly in Western Australia, and compares them to the sugar cane crop production system—a similar system producing a high volume, low-value, low density product. Crop production systems play a critical role when considering improvements to supply chain management.

1.1 Cropping System

1.1.1 Historical Perspective

Mallee System

In Australia, the extensive arable agriculture land comprises of, on average, a 250 km wide belt between the high rainfall forested eastern, southern and south-western coastal regions and the arid interior of the continent. This region lies between the 300 and 600 mm mean annual rainfall isohyets (see Figure 1.1) and contains the bulk of the nation's ~60 million ha of arable land. This land was originally vegetated with native eucalypt woodland/shrubland, and is now known as the 'wheatbelt' or 'wheat/sheep zone'.

The wheat belt consists generally of old, geologically stable regions of low relief with winter dominant rainfall and an excess of evaporation over rainfall with the rainfall being captured by the generally deep soils and discharged in summer through transpiration by the deep-rooted native vegetation. This balance between rainfall and evapotranspiration meant that the small amount of salt arriving by rainfall accumulated in the deep soil profiles with stream flow volumes low. The natural ecosystems had; relatively dry subsoil profiles, a substantial amount of salt in stable storage in the deep subsoils, groundwater systems that were not extensive, and stream flow that was intermittent but relatively fresh.

The replacement of the perennial woody vegetation by winter-grown annual crops and pastures leads to a small but significant reduction in plant water use forcing a very large change in the storage and stream flow components of the water balance, such that the hydrological character of the whole landscape is slowly but comprehensively changed (Bartle and Abadi, 2010). Groundwater systems progressively expanded in thickness and area, to intercept and mobilise previously stable soil salt stores. The hydraulic conductivity and slope of the saturated layer /aquifer is generally low causing the water to move slowly downslope. The low relief means that when brackish or saline groundwater eventually intersects the surface, it can discharge over extensive areas, degrading soils and streams. By 2050, the forecast potential for damage to agricultural land, remnant vegetation and infrastructure is considerable, totalling about 11 million hectares of agricultural land, 2 million ha of remnant vegetation, 39,500 km of streams and lake perimeters, 3,600 km of railway, 55,400 km of roads and over 200 towns in WA, South Australia, Victoria and NSW (Bartle et al, 2007).

As a result, integration of perennial plants back into this agricultural system has been undertaken to halt the spread of these saline areas with the aim of preserving long-term sustainability. Because of the scale of the problem observed in the WA wheat belt, it was always recognised that this revegetation would need to be very extensive, so it would also need to sustain itself economically, to be a crop in its own right. Mallee eucalypts are one of the predominant groups of perennial species utilised (principally in WA) to address this salinity issue (Bartle and Abadi, 2010). This has provided farmers with an additional product stream (woody biomass feedstock) that provides the impetus behind this investigation.

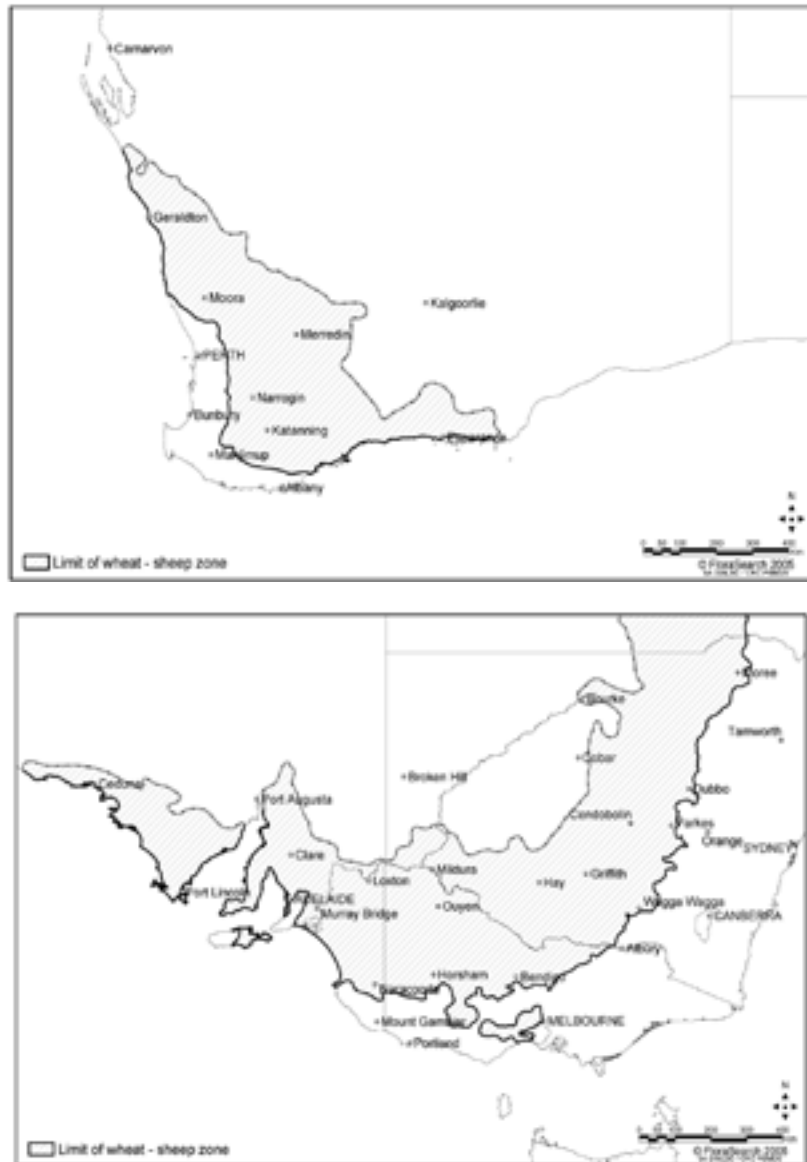

Figure 1.1 The cropping and pasture land in the 300-600 mm mean annual rainfall zones of WA (top) and south eastern Australia (bottom)

Sugar system

Sugar cane was introduced with the arrival of the First Fleet in 1788. However, early attempts to grow sugar cane around Sydney Cove, Port Macquarie and Norfolk Island were unsuccessful. It was not until the 1860s that a viable sugar cane plantation and raw sugar mill was established at Ormiston near Cleveland, Brisbane, by Captain Louis Hope.

By the 1880s, cane lands were being developed further along Queensland's tropical coast and along the northern coast of New South Wales (Figure 1.2). However, the high cost of wages for Australian workers made it difficult for the industry to compete successfully with overseas sugar producers such as Fiji, Indonesia and South Africa. To overcome this problem, cheap "contract" labour was brought in from the South Pacific islands (Kanakas). In the late 1880s regulations were introduced to control the recruitment of Kanakas and by 1908 many of the Kanakas had been returned to their homelands although some stayed in Australia. However, the need for labour on the cane fields continued and in the early 1900s a new type of canecutter entered the industry. These were young European migrants

who came to Australia to "make their fortune" on the cane fields. Italians in particular contributed to the growth of the Australian sugar industry with large numbers being brought to Australia as canecutters in the mid 1950's. The sugar industry boomed and dramatic changes were taking place within Queensland. In 1954, bulk handling of raw sugar was introduced into Australia replacing bagged sugar and mechanical cane harvesters gradually began to replace manual labour in the fields. By the late 1960s, more than 85 percent of Australian sugar crops were mechanically harvested. In 1979, Australia achieved 100 percent conversion to mechanical cane harvesting.

The Australian cane industry today produces 32-35 million tonnes of cane per year, which when processed, equates to around 4.5-5 million tonnes of sugar, the majority for export markets.



Figure 1.2 The cane growing regions on the NE seaboard of Australia
(source : www.canegrowers.com.au)

1.1.2 Crop Species

Mallee System

Mallees are multi-stemmed native eucalypt low tree or shrub species. They are deep rooted and sprout or coppice freely after the main trunk has been damaged by fire or removed for biomass. The range of mallee species planted in WA (and also in NSW and Victoria) are detailed in Table 1.1.

Table 1.1 Mallee species used for plantings in WA (source Oil Mallee Association)

Species	Proportion of total trees established (%)
<i>Eucalyptus loxophleba</i> subsp. <i>lissophloia</i>	39%
<i>Eucalyptus kochii</i> subsp. <i>plenissima</i>	23%
<i>Eucalyptus kochii</i> subsp. <i>borealis</i> *	18%
<i>Eucalyptus loxophleba</i> subsp. <i>gratae</i>	8%
<i>Eucalyptus polybractea</i>	8%
<i>Eucalyptus kochii</i> subsp. <i>kochii</i>	2%
<i>Eucalyptus myriadena</i>	1%
<i>Eucalyptus angustissima</i> subsp. <i>angustissima</i>	1%
Total	100%

* Formerly *Eucalyptus horistes*

Sugar system

The world's commercial crops of sugar cane originated with the so-called noble canes (*S. officinarum*) found in the New Guinea region. These were soft, sweet, and suited to commercial culture in tropical environments. In 1888 it was discovered that sugar cane could produce fertile seed; this began a new era in the production of hybrids. *S. spontaneum* and later *S. sinense* (both of which probably originated in the South-East Asia region) and also *S. robustum* (believed indigenous to New Guinea) were used in inter-specific crosses with *S. officinarum* to increase the vigour and disease resistance of the last mentioned. Today the world's sugar industries are dependent mainly on hybrid canes; many of them are made up of three species of *Saccharum*.

1.1.3 Locality

Mallee System

Mallees can be successfully cultivated on only a small proportion of the land in order to provide the benefit of being a sink for the water table. In the wheat belt this will usually be <10% of any farm or catchment, in the form of linear or contour belts called alley farming (see Figure 1.3). These mallee belts impose varying levels of moisture competition on adjacent annual crops and pastures, depending on site specific considerations such as soil, slope and adjacent crop type. This is however partially offset by the capture of surplus water from the annual crop area that might otherwise contribute to seasonal waterlogging and salinity.



Figure 1.3 Two row alley farming on the contour near Trayning WA.

Rainfall (considered in isolation) is not always a limiting factor in determining whether a site is suitable for mallees. Moisture availability, both surface and subsurface, which a mallee has access to over its lifespan to continue to survive and grow, is critical. As the mallee grows, its reliance upon surface moisture reduces as it accesses groundwater. In their natural environment, mallees occur in low to medium rainfall zones, generally 250 – 600mm.

Mallees can be planted on a range of soil types, ranging from sandy clays through clay loams to heavy clays. The soil type identified will assist in the selecting the species to be planted on the site. Mallees will tolerate saline soil conditions up to 100 mS/m. Higher salinity levels (up to 200 mS/m) will have an effect on biomass production and the final commercial yield of a mallee crop. It is possible, however, that when growing mallees for environmental purposes, adequate growth rates will be achieved and sustained at these higher salinity levels.

Sugar system

Commercial cultivation of sugar cane is largely confined to the tropics. Outside the tropics the growth of the crop is limited by frost incidence; thus the southern limit of cane growing in Australia is the Clarence River in northern New South Wales.

For good growth, sugar cane needs at least 1100 mm of rain (or irrigation) per year, warm sunny weather, freedom from frost and deep, well-drained soil. Fine, cool weather immediately before harvesting retards plant growth and increases the sugar content.

Sugar cane is a versatile crop and will grow satisfactorily on a wide range of soils. Good drainage is essential. Surface levelling and underground drainage to eliminate waterlogging are recommended practices; research has demonstrated economic yield increases from improved drainage and reduced water-tables in sugar- growing areas.

1.1.4 Growth Cycle

Mallee System

Mallees have an initial phase of growth which may be described as a sapling stage, leading to the first harvest. From then on the crop can be repeatedly harvested as it regenerates readily from the lignotuber, which is a modified underground stem. In old mallee stands in Victoria and NSW, mallees have been harvested repeatedly on short cycles (typically one to two years) for many decades. In the industry model promoted in WA, where harvest intervals will be much longer (up to ten years) there will be some mortality but as there has not been any sustained harvesting of mallees in this system, it is not known how long a stand of mallees will persist, or how effectively the survivors will compensate for losses (by utilising the resources previously used by dead individuals) over several decades. The issue of mortality is covered further in section 1.1.5 below.

The time between harvests varies mostly with available soil moisture and rainfall; growth on 19 widely dispersed trial sites in WA, measuring both unharvested mallee growth and growth of three and four year old coppice has recently been published by Peck et al (2011). Applying the estimation that harvesting efficiency demands at least 20 green tonnes of biomass per kilometre of row, the time to first harvest and between subsequent coppice harvests will range from four to ten years. Some poor sites may take longer and perhaps should be considered unsuitable for mallee cropping. Harvesting may also need to take into account the land use adjacent to the mallees at harvest, and it may be preferable to avoid harvesting the mallees at a time when high return annual crops in the adjacent alleys are in the latter half of their growing season.

The complexity of harvest scheduling makes coordinated regional harvest planning essential to give markets certainty of consistent supply. However the mallees will not deteriorate in quality if left another season or two, provided the largest individual plants do not grow beyond the capacity of the harvester.

Table 1.2 The changing harvest cycle length due to configuration and climatic conditions

Rainfall	1-row belt	2-row belt	4-row belt
300-400	5, 4, 4	8, 6, 6	12, 10, 10
400-500	4, 3, 3	6, 4, 4	8, 6, 6
500-600	3, 3, 3	5, 3, 3	7, 5, 5

Sugar system

The current sugar production system consists of the plant crop and three or more ratoons that are driven by the incidents of disease and weeds. The crops in the warmer growing regions (all of Qld) are harvested every year (weather permitting) with a greater proportion of standover crops predominating in the cooler areas of Northern NSW. A legume crop or other small crops may be grown in the fallow period between plough-out and replanting, or to break the monoculture.

1.1.5 Crop management

Mallee System

Seedlings and planting represent the most costly stage of establishing a mallee planting, often representing up to 40% of the total establishment cost, estimated at \$1650 / planted hectare (URS 2008). It is essential trees are properly planted to achieve high survival levels and ensure young seedlings become established quickly. The stocking (or planting density) depends on the species selected, the site characteristics and its carrying capacity and the proposed uses and desired land management objectives.

Seedlings can be planted using either a machine or by hand. Machine planters are towed behind a tractor and operate as a one pass system incorporating all aspects of the site establishment.

Weed control is the most crucial element to establishing any tree crop. The competition between weeds and young trees for valuable moisture and nutrients is very high. It is essential trees have minimal, but preferably no competition, to encourage rapid early growth and to maintain growth rates.

Harvesting is considered to be a single row operation so inter-row spacing must be at least two metres to facilitate vehicular traffic.

Sugar system

Commercial sugar cane is propagated vegetatively. Sections of the stalk (approximately 150-300 mm long), called setts and carrying at least one bud are planted in mechanically in rows with spacing between rows ranging from 1.4 to upwards of 2 m, sometimes in dual rows. After a few weeks new shoots grow from buds on the joints of the setts and break through the surface of the soil. Up to 12 stalks grow from each sett, forming what is known as the stool of sugarcane. The resulting cane stalk is typically 2 to 4 m in length and 25 to 50 mm in diameter depending on the cultivar and growth conditions.

Sugar-cane is normally harvested annually at ground level and the underground buds then shoot to a produce a ratoon crop. For Queensland, an average of three such rations is grown before the stubble is ploughed out and the land prepared for replanting, or a break crop. Under the more temperate New South Wales climate most crops grow for 2 years before harvest and generally only one or two ratoons are grown.

The crop, by virtue of the weight of green material produced per hectare, causes a heavy drain on plant nutrients. Factors influencing the amount of fertiliser applied include crop class (plant or ratoon), available moisture, previous fertiliser history and soil type. Responses from nitrogen, phosphorus and potassium fertilisers on plant crops are different from those of ratoon crops. Usually more phosphorus is applied to plant cane and more nitrogen and potassium to ratoon cane. Irrigated crops or crops grown in reliable rainfall areas can utilise more fertiliser than crops grown in drier areas.

A good legume crop ploughed-in prior to planting provides some nitrogen for the plant crop. Both plant and ratoon crops receive nitrogen in the planting mixture and as a subsequent further dressing.

Sugarcane needs strong sunlight, fertile soil and lots of water (at least 1.5 metres of rain each year or access to irrigation) to grow. A crop of cane takes about 9-16 months to grow in Queensland. In northern New South Wales (where it is cooler) it takes 18-24 months to grow. Typically, a cropping cycle comprises one plant crop and 3-4 ratoon (regrowth) crops.

During harvest, the cane harvester drives along each row and cuts the cane stalk off at the bottom of the plant. The long stalk is then cut into many shorter lengths called 'billets' (around 30 cm). Another

machine known as a cane haulout drives alongside the harvester, collecting all the billets. The cane haulout collects billets until its full, then drives across the paddock to the road or rail, where it unloads its contents either into a semi-truck (for road transport) or mill bins at local sidings on the nearest railway track (for train transport). Once sugarcane has been harvested, it must be transported to a sugar mill as soon as possible. The longer it takes, the more sugarcane juice stored in the stalks will evaporate - so it is important that it arrives within 16 hours of being cut, to minimise deterioration.

Australia's sugarcane is harvested during the drier months in tropical climates – between June and December each year - depending on the weather.

1.1.6 Farming systems (other crops, field layout, machinery)

Mallee System

The mallee coppice crops are typically grown in belt configurations, commonly in four rows per belt, but increasingly with two rows, with the inter-belt alleys varying, from 40 to 100 metres or more across. There is a two metre buffer zone either side of the outer rows of a belt, and a competition zone beyond that as shown in Figure 1.4. The width of the cropping zone is driven by the cereal production system (i.e. the seeder and spray boom widths).

An inter-row spacing of at least three metres is recommended and the intra-row spacing is typically two metres to maintain a reasonably consistent flow of material into the harvester, which equates to 1,430 mallees per hectare of land directly occupied by the belt. The density of planting has varied as the industry has developed, with some very high densities in early plantings, but current indications are that a wider inter-row spacing not only improves access for harvesting but will improve yield per kilometre of belt. The use of more than two rows is not efficient in most circumstances due to the strong edge effect that develops as competition within the belt increases with age (Peck et al 2011). The productive capacity of the strip of land occupied by the belt is captured by two rows, and adding more rows merely distributes the production of biomass across more mallees and increases competition between them.

Establishment is by seedlings and some indicative establishment and ongoing management costs are presented in Table 1.3 from the 2008 Mallee Industry Development Plan (URS, 2008). Costs are likely to be lower if operations are undertaken by the farmer, with total establishment costs typically being approximately \$1,000 per hectare, with the purchase of seedlings being about 60% of that cost.

Table 1.3 Establishment and management costs for contract operations (adapted from URS, 2008)

	Cost per planted hectare
Establishment, site preparation, weed control and planting	\$1,100
Seedlings at 1,430 per hectare	\$500
Second year management	\$200
Subsequent annual management	\$60

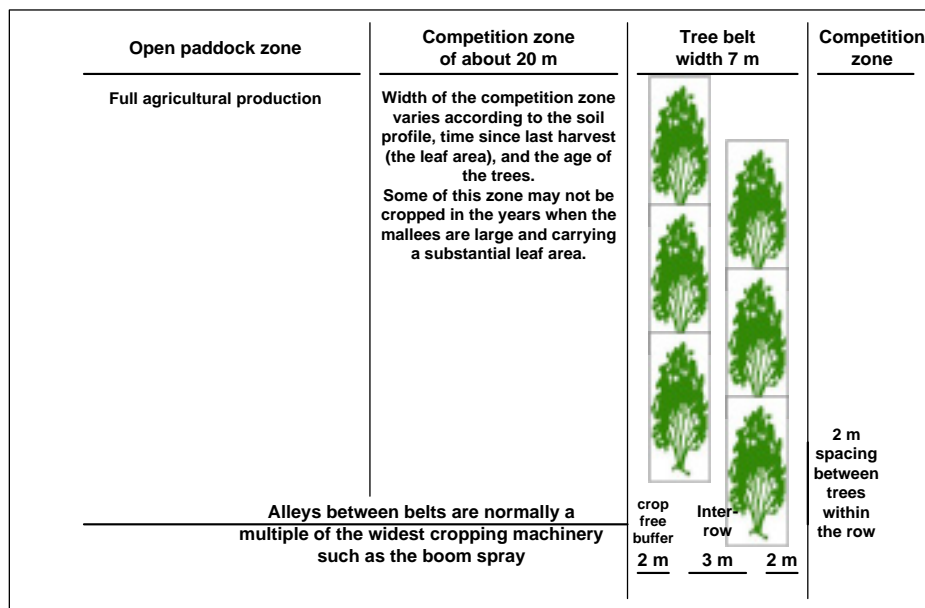

Figure 1.4 The mallee belt system integrated with agriculture

When trees are planted in alleys in a cereal production system, it should be noted that they need to be regularly harvested to reduce the moisture competition with the adjacent crop, however mature trees do provide a good wind break and important other collateral benefits such as resilient landscapes and environmental biodiversity.

As the economics of efficient harvesting and supply is reviewed, there is an increasing move towards block plantings to optimise the system and maximise the income, with opportunity to mix block planting close to processor with alley planting in remote areas as part of wheat/pasture production.

Spacing requirement for bulk planting and roles of differing soil and rainfall regimes (compared to alley planting) all need to be optimised, as does the role of density of trees on the makeup of biomass (the proportion of leaves decreases with denser/closer plantings). The impact of planting layout on harvester performance, along with planting on the contour verses in a straight line and associated use of GPS guidance, are other important considerations.

Sugar system

The Australian sugar industry had been based on a burnt cane harvesting system since the 1930's but with the advent of large scale mechanical harvesting in the 1970's and the demonstrated benefits of a green cane trash blanket during the 1980's the industry transformed to predominantly green cane harvesting. Further detail on these systems is provided in Section 2.1 of this report.

Green cane harvesting provides substantial improvements in profitability through labour and cost savings, reduced tillage and improvements in soil organic matter, nutrient retention, bio-diversity, soil water retention and reduced costs of weed and insect control (Garside et al, 1997).

Almost 80% of the industry now cuts green. There has also been significant move towards minimum tillage and controlled traffic to reduce compaction caused by traffic associated with harvester and haulout machinery. A major problem with compaction in the sugarcane cropping system has been due to mismatched row and wheel spacings. Traditionally the sugarcane crop has been grown on 1.5 m rows whereas harvesting and haulout equipment has a standard 1.85 m wheel spacing resulting in encroachment on cropped areas causing compaction (see Section 2.2.1).

A key part of the farming system has been growing rotation crops such as legumes which is harvested or left unharvested. Residue is then mulched into the soil or sugarcane planted into the residue. This cropping system provides better-balanced biology and control of root pathogens, helps biologically fix nitrogen, reduces the need for fertiliser nitrogen and improves soil organic matter and cane yield.

Sugar cane systems all rely on GPS guidance for precision planting and subsequent land management and harvesting. The planting machine leaves the field in a furrowed condition, the sett being in the bottom of the furrows covered by 50 to 100 mm of soil. Subsequent cultivation is designed to destroy young weeds and grass growth and gradually fill in the furrow as the cane stools develop so that by harvest time a flat surface or slight ridge along the length of the cane row facilitates harvesting. Block sizes are driven by field width and also equipment considerations such as boomspray and planting rigs, but also irrigation logistics

1.2 Crop Components and Uses

1.2.1 Crop Components

Mallee System

The conceptual biomass harvest and supply chain is based on principles described by Giles and Harris (2003) and the current development of a prototype harvester by the Future Farm Industries CRC and Biosystems Engineering is turning the concept into reality. The harvester is self-propelled, straddles a single row when operating and moves continuously along the row. All above ground biomass is collected and chipped by the harvester and delivered continuously into tractor drawn haulout bins and the haulouts transport the chipped biomass out of the paddock to a roadside landing. A short-term surge buffer at the landing, between the infield operations and the road transport stage, will not permit any sorting of the material, so the delivered product at the processing facility will be the green mixed whole-tree biomass.

The chipped biomass in its unsorted state is a mixture of wood chip, leaf, and residues of assorted fines, bark and small twigs. The mixed material in chipped form is liable to decompose significantly over a period of about a week. It is preferable to sort the leaf and residues from the wood chip if the biomass is to be stored for more than a few days because clean chip can be stockpiled relatively easily in its ex-harvester form, whereas the foliage and finer materials must be dried prior to long-term storage. Decomposition of finer material will degrade the product, fungal spores from the decomposing material represent an OSH issue, and spontaneous combustion of stacks is also a significant risk.

The proportions of wood, leaf and residues is about one third each but these values vary widely according to tree species and age at harvest. Biomass composition is more complex than for sugar cane as mallees may be harvested over a wide range of ages, or over a wide range of mallee sizes. Size (above ground biomass per mallee) is likely to be more important for harvest scheduling than chronological age. Harvest will be timed according to the yield per length of row so as to manage the cost of harvesting.

As mallees grow the proportions of their biomass in the form of wood, leaf, twig and bark varies (Peck et al, 2011). The biomass composition varies according to many factors other than mallee size, perhaps the most significant being the availability of soil moisture; with better access to moisture, mallees can sustain higher leaf areas. Mallees growing in dense blocks are typically observed to have small crowns at the top of the plant, whereas mallees in narrow belts with greater access to usable soil moisture will carry heavier crowns, sometimes extending almost to the ground.

However across all species observed in the work of Peck et al (2011), the trends are that with increasing age or size, the proportion of wood increases, the proportions of leaf and twig both decline, and bark varies relatively little. There are differences between species and within species there are also differences between saplings, or previously unharvested mallees, and regenerating coppice.

In saplings:

- Wood varies between 10% and 30 % of biomass for 10 kg mallees to about 45% for mallees weighing 100 kg. The range observed in the smaller mallees is partly according to species.
- Twig and leaf vary together and are very similar proportions of total biomass. In small mallees both fractions represent 30% to 40% of biomass, falling to 20% to 25% for large mallees.
- Bark typically comprises between 5% to 10% of biomass for all mallee sizes, though in *E. kochii* ssp *plenissima*, the proportion of bark rises to 15% in large mallees at the expense of leaf and twig proportions.

In regenerating coppice:

- Wood varies between about 15% in all species for small coppice to 25% to 40% in 100kg coppice, with different species having different proportions in these larger mallees.
- Leaf and twig again vary together, being about 40% each in small coppice, down to about 30% in large coppice.
- Bark is again a small proportion, being about 5% of biomass and a little higher in large *E. kochii* ssp *plenissima*.

The market requirements for biomass composition, the efficiency of harvesting, and the economics of biomass production all influence the composition of the biomass. At this stage, before market development has occurred, we can only define trends and directions of influence.

Wood is likely to have the highest value as a fuel because it has low ash content (Peck et al 2011; Wu et al, 2011). It is also the biomass component most likely to have other market potential, such as charcoal production. It will be easier to separate wood chip from the rest of the biomass than it will be to subdivide the rest of the biomass into leaf, twig and bark.

Leaf is likely to have next highest value as it contains the eucalyptus oil (2-3% of total fresh weight of leaf) and after distillation, the bulk of the material may represent a useful relatively low grade fuel source. This residue may contain undesirable levels of alkali metals and alkaline earth metals, and other problematic elements such as chlorine. Recent work has recorded reduced ash content after hydrodistillation (Wu et al, 2011) but steam distillation may produce different results.

Twig will have value as a relatively low grade fuel source but often with less ash than the leaf and bark (Peck et al, 2011).

Bark has relatively high ash but as it is a small proportion it will presumably have only a modest impact on the value of leaf/twig residue with which it will be mixed.

It would appear that harvesting bigger mallees will produce the most valuable biomass (highest wood proportion) and saplings (previously unharvested mallees) will produce a higher wood yield than coppice. There are modest differences between species, with *E. loxophleba* ssp *lissophloia* producing higher wood proportion biomass than *E. polybractea* and *E. kochii* ssp *plenissima*; however the yield of wood per kilometre of row or hectare per year may not be superior for *E. loxophleba* ssp *lissophloia* for all soil types or climatic conditions. *E. loxophleba* ssp *lissophloia* also produces a lower quality eucalyptus oil than the other two species.

E. loxophleba ssp *lissophloia* also appears to produce the greatest wood proportion in large 100 kg mallee coppice (about 45%) compared to *E. polybractea* (about 35%) and *E. kochii* ssp *plenissima* (about 25%). Experience to date with the harvester indicates that for a given weight, large coppice are

easier to harvest than large saplings. It may be that coppice rotations will be harvested on longer cycles than previously anticipated to improve harvester efficiency and to produce a better quality biomass product.

In general it appears that choosing the most productive species for the environment, to produce the most wood per kilometre of row or hectare, and growing larger mallees to allow higher harvester efficiency will remain the best approach. However there will be a limit (as yet undefined) to the size of mallee that may be harvested with an over-the-row chipper harvester. Extending the harvest interval has an economic penalty because of the effect of discounting on the value of future revenue.



Figure 1.5 Six year old *E. loxophleba* subsp. *Lissophloia*

(Note growth suppression in internal row, which occurs at most sites with belt configurations wider than 2 rows)

Sugar system

All cane produced in Australia is mechanically harvested. The chopper-harvester, removes the top, cuts the cane stalk at ground level and chops it into billets 200 to 300 mm long. Extraneous matter, mainly tops, leaves and trash, is extracted by a blast of air, the chopped cane loaded into a bin drawn alongside the harvester and the extraneous matter discharged into the field. In whole cane harvesting operations all material is transported to the mill. Chapter 2 provides a detailed review of harvesting systems.

The average yield and the sugar content of the cane has stayed reasonable stable over the last 15 years (approximately 80 t/Ha and 14% commercial cane sugar (CCS) respectively) although there have been some fluctuations in both parameters, primarily driven by climatic conditions. The components of this yield will vary with age of crop, region and variety. Table 2.4 provides a summary of typical cane composition, typically 90% clean cane, 4% tops, 5% trash and 1% dirt. Extraneous matter affects sugar quality and causes problems in the manufacture of raw sugar. This extraneous matter includes tops, trash and leaves, and roots and soil, included with the chopped cane. Extraneous matter will also impact bulk density. Extraneous matter levels of 6% are typically found in burnt cane rising to 12% in green cane and 25% in whole cane. Bulk density varies between 200t/m³ for whole-cane to 380t/m³ burnt cane (Table 2.3).

1.2.2 Product Characteristics

Mallee System

It is imperative that biomass feedstocks from short rotation woody crops have multiple uses so that higher value fractions will increase the value of biomass produced in the paddock. The importance of multiple uses for mallee biomass, particularly in relation to eucalyptus oil, has been discussed in more detail by Cooper et al. (2001).

The biomass must be comminuted in some way to achieve acceptable bulk handling characteristics and increase the bulk density of the biomass. As a bulk material, the biomass must flow as well as possible. This means minimising the proportion of long pieces such as twigs, sticks, and the long slivers that can be produced from larger wood sections. Traditional wood chipping is seen as the most suitable method of comminution as it produces a flowable material with an acceptable level of whole twigs and small sticks.

Mallees have the potential to yield a wide range of products in association with their environmental benefits (see Table 1.4). Section 4.4 of this document provides further detail.

Table 1.4 Potential uses of mallee.

Eucalyptus oil	For use in industrial solvents, fuel additives and specialised cleaning products. Presently, most widely used within the pharmaceutical industry.
Activated Carbon	Used primarily within the gold industry and for water purification.
Wood composites	Such products include Medium Density Fibreboard (MDF), cement wood products and particle board.
Biomass Fuel	Using mallee biomass as a renewable resource to produce electricity, fuel pellets, or thermal boiler fuel as a basic chipped, dried product.
Liquid fuel	Production of ethanol or pyrolysis bio-oil from mallee biomass for transport fuels.
Carbon sinks	Planting of mallees to absorb and store carbon based pollutants from the production of Greenhouse gas emissions.

In consideration of the specific markets that the biomass is to be used for, the fundamental market characteristics must be considered. If the wood chip is to be used to make charcoal products, larger chips may be desirable as the smallest dimension (typically the thickness) influences the quality of the end product. Consistency in chip size is also a factor so that the chips all pyrolyse over a similar time. If leaf oil is the target market, a comminution process that strikes an optimum balance between flowable bulk biomass and minimum leaf damage is preferred, as the leaf oil is volatile and increased leaf damage increases oil evaporation.

Apart from extractives such as oil, foliage will most likely become bioenergy feedstock which does not have very specific particle requirements. Many bioenergy processes (e.g. co-firing with coal, fuel pellet manufacture and pyrolysis for bio-oil) require fine grinding of the biomass prior to the conversion process. Wood chip for any industrial process needs to be sound and of consistent size. The comminution step on the harvester must maintain a focus upon wood chip quality.

Sugar system

In addition to raw sugar (the primary output), the mills produce useful by-products such as molasses and bagasse. Molasses is the dark syrup separated from the raw sugar crystals during the milling process. It is used as a raw material in distilleries where industrial alcohol (such as ethanol), rum and carbon dioxide are made. Molasses is also used in feed for animals such as cattle, and is sold to both the domestic and export markets. Section 4.1 of this document provides further detail.

Bagasse is the expended cane fibre which remains after the juice has been extracted. It provides nearly all of the fuel required for steam and electricity generation at the mills. In addition, some mills (e.g. Condong and Broadwater in NSW) have moved towards whole crop harvesting in an endeavor to generate a significant amount of electricity that is added back into the grid. This is an ongoing work.

Bagasse is also used as mulch (and potentially as a stockfeed) in areas where excess bagasse is produced. By-products ash and filter mud are used as a fertiliser on cane farms and gardens. Boiler ash is "scrubbed" from the mill stacks and filter mud is the residue left after the sugar has been clarified.

Ash and filter mud are used as soil conditioners on cane farms and gardens. Boiler ash is scrubbed from the mill stacks before the exhaust gases are released into the atmosphere. Filter mud is the residue left after the sugar cane juice has been clarified.

Molasses is the black syrup remaining after the sugar syrup has been boiled and passed through the centrifugal for the last time in the mill or refinery. About 50 percent of the molasses produced in Australia is exported and the remainder is used in stock feed and in distilleries where industrial alcohol (ethanol), rum and carbon dioxide are made.

1.3 Supply Areas

1.3.1 Supply areas

Mallee System

Since the early 1990s almost 13,000 ha of mallees have been established in WA but there is potential for expansion into other areas of the wheat/sheep zone in southern Australia (see Figure 1.1). The mallee in WA is the largest resource available for start-up industries and market development but it is relatively scattered and not properly quantified at present. The two most concentrated centres of activity are in the Central Wheatbelt (the Shires of Dalwallinu, Mount Marshall and Koorda) and the Upper Great Southern (Shires of Narrogin, Cuballing, Wickepin, Wagin and Kulin) (URS, 2008). Each of these regions could possibly supply 20,000 to 50,000 green tonnes per year on sustainable basis. This figure could be properly determined with a GIS-based inventory and site assessment.

The total land area in southern Australia that may be suitable for expansion of mallee and other short rotation woody crops (see Figure 1.1) is summarised in Table 1.5(a). There is potential for expansion of the model into central Queensland, using appropriate species for that environment. The estimates in the literature of potential woody biomass production from the land area in Table 1.5(b) vary widely, depending upon the assumptions of the proportion of land area that will be planted and the growth rates.

For this description of potential biomass production, we have followed the example of Peck et al (2011), where it is recognised that mallees need to be big enough for economical harvesting, in that there must be about 20 green tonnes or more of biomass per kilometre of row to achieve economical pour rates through the harvester. It is not the maximum mean annual increment that determines potential production, but the mean annual increment over the whole rotation from one harvest to the next. This can often be less than the maximum MAI, especially in the lowest rainfall zones where

annual growth rates are observed to decline part way through a rotation when rotations of seven or more years are required to achieve harvestable yields.

The proportion of land area that is planted to mallees or other crops is a very broad assumption, but the assumptions in Table 1.5(c) are that a small proportion of land will be utilised because farmers will opt to use mallee as a diversification of the farm enterprise, not as the principal farm enterprise.

Potential production is not adoption. Estimates of future biomass production made by the Future Farm Industries CRC, taking an industry development perspective from the biomass processor side, rather than starting from the area of land under agriculture, indicate that in the southern states, about 160,000 to 170,000 hectares of land may be under mallees, producing about 2.6 million green tonnes per year, by 2025 – 2030 (FFI CRC, 2010). The potential to produce significant quantities of biomass exists due to our large land base, but development of processing industries will strongly influence how quickly this potential is realised.

Table 1.5(a) Land area devoted to cropping and pasture in Southern Australia (Bartle et al, 2007)

State	Millions of hectares by rainfall zone			Totals
	(mm mean annual rainfall)			
	300-400	400-500	500-600	
New South Wales	4.2	7.3	5.3	16.8
South Australia	4.3	2.5	1.1	7.9
Victoria	2.9	2.1	2.2	7.2
Western Australia	10.9	3.8	1.9	16.6
Totals	22.3	15.7	10.5	48.5

Table 1.5(b) Mean annual increment to harvestable size¹ of mallees growing in two row belts for each rainfall zone (adapted from Peck et al 2011)²

	Rainfall zone (mm mean annual rainfall)		
	300-400	400-500	500-600
Age at harvest	7	5	4
MAI (green tonnes per hectare per year)	7	14	15

¹ Harvestable size is defined as when the crop yields about 20 green tonnes per kilometre of row, which allows an efficient pour rate of at least 60 gt/h to be achieved by the harvester.

² The data have been adjusted to allow for the differences in assumed belt widths; Peck et al (2011) assumed a 6 m width occupied by a 2 row belt, we have assumed a 7 m width, with a 3 m inter-row spacing to allow better access for harvesting.

Table 1.5(c) Potential annual biomass production for mallees growing in two row belts, by rainfall zone

	Rainfall zone (mm mean annual rainfall)			Total annual biomass production
	300-400	400-500	500-600	
<u>Assumed</u> proportion of farmland planted to woody crops	3% - 5%	4% - 6%	5% - 7%	
Potential annual biomass production (millions of green tonnes per year)	4.7 – 7.8	6.4 – 9.6	9.6 - 13.5	21 – 31 million green tonnes

Sugar system

Sugar cane is grown mostly within 80 km of the coast, along the plains and in river valleys of northern New South Wales and Queensland. The cane lands stretch about 2100 km in a discontinuous strip from Maclean, near Grafton, New South Wales, to Mossman, Queensland (Figure 1.2). The principal centres of production are in the neighbourhood of Cairns, Innisfail, Ingham, Ayr, Mackay and Bundaberg. Queensland accounts for about 95% of Australia's raw sugar production, and New South Wales around 5%.

Sugar cane production is limited to areas of high and evenly distributed rainfall or where irrigation is available. Rainfall ranges from 4000 to 4500 mm in the Innisfail area (Tully, Innisfail, Babinda), through 1750 mm at Cairns-Mossman and Ingham, 1500 mm at Mackay, 1100 mm at Bundaberg and 1000 mm at Ayr. All cane at Ayr is intensively irrigated. Some supplementary irrigation is also applied at Bundaberg and Mackay.

More than 4000 sugar growing farms operate along Australia's eastern seaboard. While the average size of a cane farm is 70 hectares, with an annual sugarcane production of 7000 tonnes, some are in excess of 1000 hectares. While there are still a number of smaller farms, average farm size is increasing each year, as the number of growers contracts and area farmed expands.

1.3.2 Nature of future expansion

Mallee system

Future expansion in WA will be commercially driven. The initial planting effort was strongly encouraged by environmental management objectives and associated public funding, but environmental drivers are now less influential than in the 1990s. Farmers with mallees are now awaiting the development of markets and the harvesting of the resource they have already established. This same pattern of strong initial farmer support followed by the adoption of a wait-and-see approach before critical mass is achieved may be repeated in other regions of the wheatbelt of southern Australia unless there is a coordinated whole-of-industry development process.

The pause in expansion of the WA mallee resource does not mean farmers are unaware of the environmental benefits, even though these benefits are difficult to quantify and include in conventional economic analyses. Farmers may adopt new enterprises for a range of reasons, not all of which are strictly economic. The drought tolerance of deep-rooted woody vegetation, the ability to utilise rainfall outside the winter cereal season and aesthetic values may all play a part.

A social survey by Baumber et al (2011) of prospective mallee growers in central NSW indicates that a significant proportion of farmers do not see crops like mallee as being directly competitive with annual cropping and grazing but more as a supplementary production system that may help to even out the fluctuations in farm income, even though the return per hectare may be lower than the long term average grain cropping returns.

Farms are also increasing in size and there is a tendency to focus on annual cropping on soils that respond best to expensive cropping inputs. This may leave other soil types available for mallee as a land use with relatively modest returns but low inputs after the initial establishment.

Sugar system

Expansion in the sugar industry will primarily take place through consolidation and increase in contract area in existing mill supply regions. Consolidation is possible thanks to advances in farming technology, economies of scale, a stable market and available capacity in milling facilities. Given the large investments in milling infrastructure there is a desire to maximise volumes processed and extend the length of harvest season. International ownership of milling and processing facilities may have an impact on industry growth as would future expansion into biofuel markets. It is unlikely that new mills will be developed, however expansion of existing mill processing facilities to increase efficiency and diversify product streams is likely. There are now 24 sugar mills down from a peak of 33 mills.

1.4 Resource management

1.4.1 Identification of existing and future supply areas

Mallee System

Existing resources in states other than WA are relatively small and they represent the initial trial plantings that are essential to starting a new cropping system and industry. In WA the resource establishment has progressed much further, primarily on the back of the environmental planting of the 1990s.

There is also a significant but unknown resource that has been planted by various companies for carbon sequestration. The ultimate fate of these stands is hard to determine – some apparently have harvesting options within the grower contracts but there is no public knowledge about the suitability of these sites for harvesting. For example, row spacing and the number of rows in belts are possibly unsuitable if rows are too close for harvesting access, or the belts are so wide that the internal rows stop growing before they achieve yields that are sufficient to support viable harvesting operations.

The existing mallee resource which comes under the overall interest and possibly future management of the Oil Mallee Association is understood to a degree. Work is currently under way collecting better quality spatial data to enable this information to be managed in a geographical information system.

Site assessment will also be required to determine suitability for harvesting:

- Are the sites big enough to justify harvesting, or are they in proximity to other sites so that collectively the cluster is large enough to harvest?
- What is the row configuration? Spacing may be too close to allow any harvesting; length and straightness are factors that influence harvest efficiency.
- Obstructions to the harvester (such as rocks) that may damage the saw and/or start fires.
- Access to the harvester and the haulouts will need to be sufficient recognising that the haulouts will probably be larger vehicles than the harvester itself.
- Growth; this is very site specific, with several influential factors such as the suitability of the species to the site.
- Depth of accessible soil profile or the presence of a permanent fresh water table within rooting depth could have a substantial impact on the trafficability of the site.
- Competition between mallees is a significant issue, with high density blocks and belts with more than two rows on shallow soils being principal concerns (Peck et al 2011; Bartle et al, 2011).

In future plantings should be surveyed by differential GPS at the time of planting which would expedite data management and allow harvesting to be guided by autosteer from the first harvest. The existing resource will need to either be surveyed prior to harvest or surveyed by the harvester using manual guidance for the first operation. Visibility on the harvester is limited as the machine is smaller than the crop plants, and harvester operation will be a complex task making autosteer an important capability for the medium to long term.

In relation to harvest planning and resource management, the GIS capability combined with existing scheduling software from the sugar industry will make an important contribution to harvest efficiency and transport logistics. GIS will also enable better planning for resource expansion. Establishing new sites in the vicinity of existing plantings will make subsequent operations more efficient and may also be a way of bringing currently stranded assets into a harvesting programme.

Resource location in relation to biomass processing facilities is a significant factor for reducing road transport costs. However given that the land resource is all privately owned by farmers who will continue to make most of their income from annual cropping, the ability of planners in the mallee industry to significantly influence resource location will be limited. The industry will have to select from the land that is offered. Industry planners will be able to demonstrate through GIS-based planning how alternative locations and layouts will impact upon farmer payments for harvest and haulage.¹ In this way the very significant cost of harvester to roadside haulage can be minimised to the farmers' benefit.

Sugar system

The sugar industry is a mature industry that has been operating and adapting over many years to optimise supply efficiency. Current supply areas have been mapped and detailed GIS records are available industry wide for planning harvest and planting operations. Milling companies consolidate

¹ Harvest and haulout, plus road transport, will be paid by the farmers, either directly if the operations are contracted by the farmers, or indirectly through the stumpage payment if the operations are contracted to the biomass purchaser. In forestry systems, stumpage payment is the residue left after all supply chain costs have been deducted.

mapping information on a supply area basis to assist in resource management and planning. In most cases field layouts have been rationalised and information is available on potential new land for expansion. Contraction in the industry has taken place especially where urban encroachment has increased land value or where alternative high value crops (eg horticulture) have provided diversification opportunities. This has in some cases resulted in rationalisation of the number of mills serving a supply area.

1.4.2 Determination of seasonal supply volumes

Mallee system

Most of the mallee biomass appears to be destined for use as an energy resource. Energy is a commodity required, at one extreme, continuously 365 days a year, through to about 2,000 hours a year, for example during the daylight operations of a rural business operating a small boiler for process heat. There will be no seasonal demand for the energy.

The benefit of biomass as a primary fuel source is that, with appropriate storage and handling systems, it is easy to stockpile. However the difference between efficient and appropriate on one hand and dysfunctional and unaffordable stockpiling on the other depends upon the details of handling a relatively complex product. Wood chip handling is significantly different from handling whole-tree biomass, because the whole-tree material contains long pieces from the top of the branches. Some form of screening and upgrading is essential, and it may even be justified to convert the biomass to fuel pellets, because the high cost of pellet manufacture may be more than recovered by efficiency in fuel handling and boiler management further along the supply chain.

To cover for times when field operations are interrupted, it will be essential to stockpile biomass at some point along the supply chain. Interruptions may occur due to seasonal factors including unstable soils in wet seasons, mallee regeneration problems when harvesting sites where soil moisture is exhausted and the mallees are under moisture stress, or vehicle movement bans during days of high fire risk. Before stockpiling, the minimum level of processing required will be:

- Screening to remove oversize particles that are inevitable when chipping, and especially when chipping whole trees. Overs should be re-chipped back onto the screen to avoid the accumulation of a waste material that is difficult to handle and has no value.
- Separation of the wood from the rest of the biomass, because wood chip and the mixture of leaf, bark and fines will dry out and store differently.

Clean wood chip can be stockpiled green. The leaf, bark and fines mixture will need to be dried before stockpiling, and this may be easier if the eucalyptus oil is distilled from the green mass

Sugar system

Seasonal supply volumes are determined using a combination of methods. Determining mill opening and closing date and the length of milling season (typically around 20 weeks) is critical to ensure optimum use of crushing and processing capacity and to target the optimal harvesting window, which captures peak sucrose and cane quality. Stockpiling of cane as a buffer is not possible owing to deterioration of quality and harvest to crush delays of less than 12 hours are required.

Long term historical data from cane supply and associated quality records are available on a field by field basis and are used to determine anticipated seasonal supply volumes. Sugarcane crop production modeling has also been used in the industry to forecast seasonal supply volumes based on prevailing and future weather scenarios. Satellite imagery is also used in some cases to assess infield crop variability, area under sugarcane and incremental proportion of the supply area harvested as the season progresses. This provides a sound basis for estimating remaining area to be harvested and volume of cane to be delivered.

Information on tonnes cane delivered from each block of land is available from records of bin weight at the weighbridge. Each delivery bin can be referenced by RFID tag to the field of harvest and each harvester can be tracked by GPS to monitor, on a daily basis, the area harvested and delivery area supplying each bin. These systems allow users to manage the production and harvest progress and interpret remaining harvest areas and remaining supply volumes for the season. Section 6.5 of this report provides further detail on these methods.

1.4.3 Regeneration issues

Mallee system

Mallee regeneration is considered reliable and some wild stands in Victoria and NSW have been harvested for over a century for eucalyptus oil. However there are some unknowns to be discovered and limitations that must be recognised, and it is only with extended operations will we gain a proper understanding of their significance:

- Frequent harvesting will deplete the reserves of the mallee and there has been anecdotal evidence of high mortality with young mallees harvested twice in quick succession.
- Wildy et al (2003) observed that starch reserves in mallee lignotubers fell rapidly and remained low for 12-18 months after harvesting, and the root biomass took up to 2.5 years to start increasing after harvesting the above ground biomass.
- Very high mortality was observed on specific sites in the work of Peck et al (2011) where the sites had shallow soil over a saline water table.
- There is the possibility that season of harvest may be important (for example autumn harvest may increase the risk of mortality), especially if harvest frequency is high (Peck et al, 2011).

Generally, with proper management, site selection and appropriate harvest scheduling, it is anticipated that mortality will be low. However part of this appropriate harvesting may involve suspending harvesting in dry autumn conditions in winter-dominant rainfall zones of southern Australia. Stockpiling is necessary for a number of reasons and the seasonal influence on regeneration adds some importance to that requirement.

Sugar System

Sugarcane is a robust crop, however crop regeneration will be affected by multiple factors including, harvesting practices, nutrient management, fertiliser management, irrigation practices as well as weed and disease control. The use of minimum tillage and green cane trash blanketing has helped improve soil structure and organic matter resulting in improved regeneration performance. In southern, wetter and cooler areas, or areas under furrow irrigation, burnt cane harvesting is generally practiced as cane regeneration after harvest is detrimentally affected by wet and cool soil conditions under a trash blanket.

In general between 2 and 4 crops can be grown economically from a sugarcane plant before replanting is required. The factors outlined above will influence the extent yield and profitability will be compromised by growing a further ratoon rather than replanting. Disease and stool damage during harvest in wet conditions have been shown to have a significant impact on poor ratoon performance. A detailed assessment of sugarcane harvesting and ratoon management can be found in Schroeder et al (2009).

1.4.4 Optimal harvesting windows

Mallee system

Regeneration from the lignotuber is typically vigorous, but current frequency and season of harvest work has not demonstrated a difference between spring and autumn harvests in WA (Peck et al, 2011). It is commonly assumed that spring harvests will be followed by more vigorous regeneration than autumn harvests as the strongest flush of growth occurs in early summer. However this inconclusive result may have been due to the variable nature of seasons, in that summer or autumn rain does occur, albeit unreliably, and autumn harvests sometimes occurred after such events.

In operations, harvest timing may be varied according to specific site conditions. Sites most sensitive to harvest mortality will be those with shallow soil due to impeding layers in the soil or shallow saline water tables. These sites would need to be harvested only in optimal seasonal conditions such as spring and early summer. Sites on deeper soils and a history of sustained growth from year to year will presumably indicate greater access to soil moisture and could be harvested at any time of the year. Other sites may be suitable for harvesting in autumn if there has been some late summer or early autumn rainfall.

Soil conditions and soil strength will also be a factor for the use of heavy machinery. Even with high-flotation undercarriages, machines will leave ruts at the wettest times of the year and the haulouts working at high speed and with high payloads may be the worst offenders. The harvesters will spend the majority of their time on the tree belts supported by the root mats around the mallees, but the haulouts will range widely and cross concave slopes and creek lines repeatedly as they follow fences to the nearest landing. Boggging is the worst case result for both farmers, who will be left to repair the damage, and the harvesting contractor who will lose significant time.

The annual cropping programme in the paddock may also be a factor. Trafficking by harvesters and haulouts will damage crops, and to a lesser extent, pastures. High value crops late in the season may require mallee harvesting to be excluded altogether until after harvest. Precision guidance of mallee machinery to restrict soil damage to defined tracks will help to minimise the impact on annual crops and cropping soils.

Sugar System

Mill operating periods are aligned around optimal harvesting windows for sugarcane. This is driven by three key factors. Firstly sugarcane quality (in terms of extractable commercial cane sugar) which increases from winter, peaks in September and then declines with onset of the hot wet summer season, when plant photosynthesis focusses on biomass growth at the expense of sugar quality. Second the available mill processing capacity relative to sugarcane volume from the supply area. Finally the risk of rainfall and wet infield conditions which will impact harvester and hauler access and infield damage to the crop and future ratoons. The optimal harvest window will vary across the industry but typically is from July to November. Variations within a mill area will occur based on cane variety, soil type and topographical position. A rateable delivery system, where all growers supply equal proportions across the season is in place to provide equitable access to optimal harvesting windows.

1.5 Discussion and Recommendations

1.5.1 Discussion

Sugarcane and mallee systems have many similarities as outlined in this chapter. They both represent high volume, relatively low value crops, which require considerable processing and value addition to meet the selected market. Both systems have significant harvest and transport requirements using specialised equipment. In both cases delivered cost is high relative to the market price.

Sugarcane industries have spent many years researching and refining their crop production systems and associated harvesting and transport arrangements. While sugarcane farming systems have evolved to meet a specific market (ie. sugar), the mallee woody crop industry has yet to define its market.

Innovation in sugarcane farming has been largely driven by growers of a monoculture crop aiming to meet a specific product requirement (high yield, fresh, clean cane of good quality). Mallee growers in Western Australia have had multiple objectives (land rehabilitation as well as production), in integrated wheat and mallee cropping systems and have only recently started to consider mallee markets and harvest and transport costs.

The comparative assessment provided in this chapter provides mallee and other biomass supply industries the opportunity to learn from the successes and mistakes made in the sugarcane supply chain and crop production systems. Of relevance is the sugar industries move over time to:

- Modify its farming systems (eg field layout, row spacing, harvest age, input management) to maximise crop production.
- Adapt harvesting and transport systems to minimise damage to the field and plant and improve the quality of the product delivered (e.g. through trash separation, billet length, bulk density management).
- Implement harvesting best management practices which address harvest and transport requirements as well as crop agronomic requirements.

The sugar industry has also placed considerable effort in understanding and managing the various components of the harvested crop (sugar, trash, dirt) and the impact on transport and sugar processor arrangements.

Expansion in the sugar industry has generally been driven at a local mill area scale in response to market forces. Future expansion in mallee production will be driven by the market for biomass. Farming systems and layouts will need to adapt to the economics of this supply arrangement.

Management of supply areas and volumes in the sugar industry has evolved into a sophisticated system supported by the milling company. The foundation of this system is accurate GIS information on supply area, daily cane deliveries to the mill (bin weight, cane quality and field source), GPS tracking of harvesting and transport units (supporting delivery scheduling) and integrated information systems allowing real time communication to all in the supply chain (processor, haulier, harvester and farmer) on delivery information and performance. These systems could be readily customised and provide powerful tools for the biomass industry to improve its performance.

The sugar industry has limited potential to stockpile (due to cane deterioration), short harvest to crush delays (less than 12 hours) and has a 20 week processing season, all of which have driven supply chain improvements. The mallee industry has less stringent constraints on storage and supply operations but has more challenging harvesting constraints owing to the nature of the plant.

Key considerations regarding sugar and mallee crop production systems and the impact on the supply chain are tabulated in Appendix 1 of this document.

1.5.2 Recommendations

The current mallee production system (especially in WA) has been driven by the need to maximise wheat returns with potential economic returns from mallee being of secondary importance. Economic modelling to date aimed to optimise wheat production systems based on widely spaced alleys of mallee to control soil moisture and salinity.

For a sustainable woody crop industry the farming system will need to be optimised. This may be for maximum mallee profitability, where mallee is the only crop, or maximum enterprise profitability for combined wheat and mallee farming systems. This will require assessment of optimum block planting arrangements for exclusive mallee systems, or intra and inter-row spacing for integrated mallee/wheat systems. In both cases the economic return from the mallee crop and associated harvesting costs needs to be included.

Considerable capital has already been expended on establishing > 13 000 Ha of mallee in Western Australia. Changing established mallee farming systems is unlikely, due to the capital invested in establishing the crop and given that wheat production remains the main economic driver. Many plantings have been in the ground for over a decade and will need to be harvested to reduce competition with existing cereal crops. This will require alternative harvesting systems (e.g. feller buncher), which is unlikely to be economical. Thereafter a more frequent harvesting schedule can commence using the chipper harvester. This will depend on a market that can afford to cover harvest and transport costs and required margins.

Appropriate layout of block plantings will need to be determined to maximise plant growth and minimise harvest and transport costs. It is likely that mallee biomass supply to a processor will comprise block plantings close to the processor, supplemented by existing feedstock from dispersed alley plantings integrated in wheat farming systems. Block cultivation may comprise closely spaced belts (10-30m) on marginal land close to the processor. Spacing will be determined by soil moisture competition and yield. Harvest and transport logistics should be considered in determining layouts. Harvesting efficiency will be improved when the concentration of biomass per metre of row is maximised and distance between rows is minimised.

Where mallee planting is not intended for biomass removal, consideration needs to be given to protocols for carbon credits. Existing guidelines indicate 2 row mallee planting is not eligible for carbon credits. Approval should be sought for existing 2 row mallee layouts to be eligible for carbon credits. Future plantings will need to take account of carbon accounting protocols.

High accuracy GPS autosteer systems are now becoming common place on the modern farm. As mallees are a permanent feature in the landscape, any issues with compaction due to transport will be a compounding problem. As the harvest and haul equipment will have considerable mass, confining the wheeltracks to the same location will limit compaction. The ease of planting in straight line versus on the contour should be considered. GPS guidance of both the planting and harvest equipment (harvester + haulout) could prove beneficial.

Current knowledge on the importance of mallee plant structure and the influence on harvesting ability and economics (age and size of tree, number and size of stems, species differences and opportunities for genetic improvements) are based on the current alley system. This needs to be investigated for the block planting scenario. Optimum harvest age will change with conditions and market requirement which influences harvester performance.

Mallee planting, even in their current form, provides vegetative biodiversity in a wheat monoculture. The collateral benefits of this biodiversity and the associated environmental dividend needs to be quantified.

2. Harvesting Systems

In considering an agricultural system as a whole, harvesting can be seen as the hinge, or as a ridge between the pre-harvest period, corresponding to production activity and the post-harvest period, extending from harvesting to consumption.

All harvesting systems have component parts and processes. Usually the aim is to produce a quality product for the market as cheaply as possible, but other factors may need to be considered.

In the case of harvesting biomass, the aims may include improving the productivity of equipment and resources and making the day to day operations easier, safer and more efficient.

Analysing the elements and processes of a system is the first step in achieving these aims.

Key Elements

There are 3 key elements that make up any biomass harvesting system – trees, people and equipment. No matter what the system, these elements all interact at harvest time. The way the biomass harvesting system functions is the result of the interaction of these elements at harvest time.

Each of these elements has specific characteristics that need to be taken into consideration when designing the whole biomass harvesting system. These are outlined in proceeding sections with comparison to the harvesting system of the Australian Sugarcane Industry.

A change to any element of the biomass harvesting system will also have an impact on the other elements of the production system.

2.1 Harvester Design

Sugar system

One of the greatest changes in Australian sugarcane growing has been the replacement of manual cane-cutters by mechanical harvesters. The initial changes to whole-stick mechanical harvesting, introduced slowly since the 1930s, by themselves had little effect on the farming system, other than faster and timely harvesting allowing subsequent field operations to follow more quickly. However, it is difficult to assign benefits to this. It is the widespread adoption of chopper harvesters that has changed the farming system radically.

The Australian Sugarcane Industry is based on ‘chopped’ or ‘billeted cane’ rather than wholestalk cane which is still a major component of overseas sugarcane industries.

Australia pioneered the development of mechanical sugarcane harvesting. The evolution of the sugarcane harvester in Australia has been a unique blend of the developments of farmer innovators, small manufacturers, and the research and development teams of larger corporations. The pioneering ‘chopped cane’ harvester was the Massey Ferguson 515, side mounted on a farm tractor. By 1975 around 98% of the crop was cut by ‘chopped cane’ harvesters. In 1979, Australia became the first sugar producing nation to convert entirely to mechanical sugarcane harvesting.

The Australian type ‘chopped cane’ sugarcane harvester, as shown in Figure 2., is a single row, over-the-row machine with a swinging elevator capable of delivering sugarcane to either side or to the rear of the harvester. The basic principles used in ‘chopped cane’ sugarcane harvesters have not changed significantly since they were first developed. The main changes are related to improved feeding and cleaning during green cane harvesting and increased capacity.

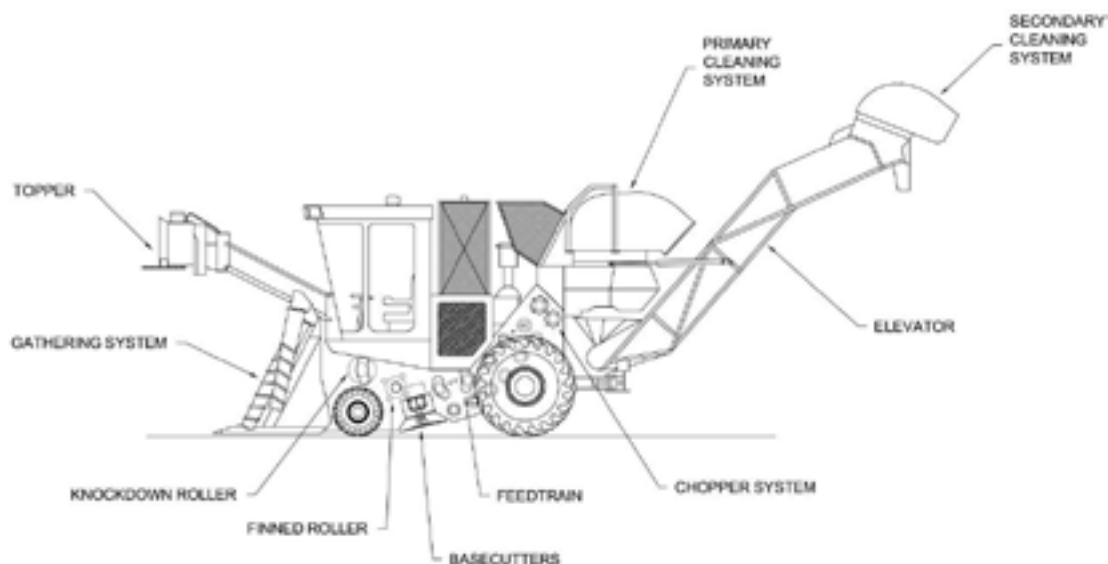

Figure 2.1 Layout of Australian standard ‘chopped cane’ sugarcane harvester

Sugarcane when harvested is a perishable product, and unlike many agricultural commodities (e.g. grains) has no value at the farm gate. Value is added through cane transport to the mill and its subsequent processing into raw sugar and other products, and through storage, marketing and shipping to the customer.

Mallee System

A harvesting system for this new crop industry is needed. Various options for harvesting and chipping mallees have previously been considered. These include:

Grapple harvesters are used extensively in Australian forestry operations. They are suited to medium-to-large trees with single straight stems. This system does not seem to have any application to multi-stemmed trees such as mallees where the cost of harvesting with conventional forestry equipment such as grapple harvesters appears prohibitive.

Feller bunchers offer the advantage over the grapple harvester of being able to handle smaller stems more effectively. They have clamps that grasp the stem and additional stems can be added to the bunch held by the clamps. When the clamps are full, the bunch is dumped. The bunches can be chipped at the stump or at the roadside. The greatest limitation to this method is the number of mallees that can be collected into each bunch, because the cost of harvesting and the collecting of the bunches depends upon bunch size.

Modified forage harvesters are used to harvest willow (in the deciduous phase) in Europe. The stems are fairly small and typically branchless and are pushed forwards as they are cut, collected underneath the harvester and chipped. The concept seems applicable to mallees, except that the mallee stems have too many branches to lie flat when the stem is cut and pushed over. Also, the close planting of mallees means the crown of the tree would fall against the next tree, further reducing the ability to lie flat.

Debarking may be important for some products, such as engineering strand lumbar (ESL). For other products such as energy or medium density fibreboard (MDF), debarking may not be as important. If debarking is required this will provide some significant challenges as the high bark/wood fibre ratio associated with small stems may result in the loss of a significant amount of saleable wood fibre during the debarking process.

Chipping is an important step in the overall delivery process, as it converts the mallee into the product received and used by the customer and increases bulk density, which acts to reduce transport costs. Chipping can be conducted infield as an integrated operation with harvesting, or at road side.

However, the nature of the mallee crop (very small, non-uniform and clumped stems, very low tonnages per paddock hectare) precludes the direct adoption of existing forestry systems, although there are proven machine components that might well provide a basis for the development of mallee specific systems (McCormack et al. 2009).

The need for a mallee harvester was identified by the WA Oil Mallee Association which led to the development of an original prototype in the late 1990s and early 2000s. The prototype harvester was developed by Dumbleyung Engineering. Initially a second hand sugarcane harvester was purchased by growers, but this failed to handle the mallee plants properly and components from this machine were used in the work done by Dumbleyung Engineering. This work showed that a commercial harvester would need to follow a single-row process that cuts the trees close to the ground, handles the trees standing upright, and chips them in a continuous flow.

In 2008, Biosystems Engineering was appointed by the Future Farm Industries CRC (FFI CRC) to design and manufacture a prototype mallee harvester.

The design approach is based on engineering principles and the premise that mallee can be harvested in a manner different from traditional forestry methods. That is, mallee is considered a large forage crop that lays between thin-stemmed crops such as sugarcane or coppice willow and conventional forest plantation trees.

Typically, current European harvester systems are based upon modified forage harvesters from agricultural machinery manufacturers. Unfortunately both the generally light weight construction of the machines and the general feeding /chopping arrangements preclude their use in the larger, tougher mallee.

Therefore, a new design was needed. A prototype was developed and incorporated the lessons learnt from the previous prototype. Its layout is based on an implement attachment (harvester head) for a utility tractor (Claas Xerion Saddle Trac).



Figure 2.2 Biosystems Engineering prototype woody crop harvester

2.1.1 Machine Definition

The purpose of any harvester needs to be outlined and what it needs to do must be clearly defined. The purpose will guide the development of design concepts and criteria incorporated into the design of the machine and ultimately leading to identified opportunities to improve design and performance.

Sugar system

The 'chopped cane' harvester is a machine that combines the task of harvesting and cleaning sugarcane crops. The 'chopped cane' harvester performs the basic functions of gathering and topping cane, severing stalks at ground level, feeding cane through a chopper system where it is cut into billets and delivering chopped cane directly into infield transporters. Depending on the cane harvesting requirements the machine may perform the additional functions of removing as much dirt, leaf and trash as possible from the cane supply (Ridge and Norris, 2000).

If a single product, sugar, is the supply-chain objective, only the cane (stalk) is of interest. In this system model, bagasse (the fibre remaining after crushing) is burned to generate power for the sugar mill, while leaves and tops of the plant are disposed of at least cost. However, the deteriorating international competitiveness of the industry in recent years has accelerated the search for additional products with potential to add value, i.e. to supplement the revenue stream.

Sugarcane can be harvested burnt, green or the whole crop. The requirements for each are quite different.

2.1.2 Burnt Cane Harvesting

Until the 1940's, most of the Australian sugarcane crop was hand cut green, with residual trash being burnt on the ground. Burning prior to harvest was allowed in some mill areas to control Weil's disease (Leptospirosis). The shortage of labour, together with the increased output of manual cutters in burnt cane, led to burning becoming standard practice after World War II.

Burnt cane harvesting involves burning the sugarcane before it is harvested. This removes leaves, weeds, and other matter, which can impede the harvesting and milling operations.

Pre-harvest burning persisted as the standard practice until the early 1980s when some growers began to experiment with mechanical green cane harvesting and associated trash blanketing. In the Burdekin region and New South Wales the crop is predominantly burnt prior to harvest. The percentage of burnt cane harvested in the Burdekin region was 94.3% of 8,225,415 tonnes and New South Wales 92% of 2,174,886 tonnes in 2007 respectively. This is substantially higher than the industry average in 2007.

2.1.3 Green Cane Harvesting

Green cane harvesting and associated trash blanketing involves harvesting the sugarcane green and separating the dry and green leaf and tops from the cane. The aim is to minimise the amount of trash harvested with the cane and allow the separated material to fall to the ground to act as a protective trash blanket.

Machine design elements have to be changed to meet the requirements for harvesting green cane when compared to burnt cane. The two most important points are that the volumetric capacity of the machine must increase and the feed efficiency must increase so that choking or glut feeding is minimised.

The use of this trash blanket as an organic mulch considerably reduces the level of soil erosion and preserves soil nutrition for crop growth. It also helps to prevent weed germination, reducing the need for herbicides. The agronomic benefits of trash blanketing, combined with greater harvesting flexibility in wet weather, prompted the development of new technology.

However, districts with high yielding one-year or two-year crops such as the Burdekin and northern New South Wales have largely avoided green cane harvesting because of harvesting difficulties and agronomic constraints. Green cane harvesting has expanded gradually since the 1980's, reaching 70.5% of the total crop harvested (34,125,022 tonne/cane) in 2007. The percentage of green cane

harvested in the Burdekin region (5.7% of 8,225,415 tonnes) and NSW (8% 2,174,886 tonnes) is substantially lower the industry average.

2.1.4 Whole-of-Crop Harvesting

Diversification from 'traditional' sugar production within the industry has focused on production of renewable energy from ethanol or electricity co-generation (Keating et al. (2002); Sutherland (2002)). Undertaking these ventures entails new challenges for the traditional organisation of the sugarcane supply chain.

Green cane harvesting leaves large amounts of trash (sugarcane dry and green leaves, and tops) for energy purposes. A significant increase in recoverable energy is achievable by incorporating a proportion of the trash in the cane supply, and separation of that trash at the mill prior to milling.

The dry and green leaves and tops represent about one-third of the total mass for commercial sugar cane. Dry leaf trash has about double the net heat energy of bagasse and about three times that of green leaves and tops. Hence, the dry leaf component is a significant energy resource and can represent a significant energy capture.

Typically, the two strategies used for whole-of-crop harvesting are green cane harvest with all material (cane and trash) transported to the mill and conventional green cane harvest with post harvest collection (baling). Typically, the additional fuel sourced from either of these two strategies is used to fuel co-generation plants. Green cane harvest with all material (cane and trash) transported to the mill is the system with the closest synergies with the Mallee biomass harvesting system.

Whole-of-crop harvesting represents a paradigm shift to the traditional burnt cane or green cane harvesting supply chain and challenges the traditional logistical operation of the supply chain. The principal of whole-of-crop harvesting is to maximise the production of co-products such as electricity and ethanol.

In light crops, harvesting the whole crop gives higher machine productivity when compared with green cane harvesting. However, in large crops, machine productivity is similar to green cane harvesting due to limitations in volumetric capacity and feeding efficiency.

The challenge for whole-of-crop harvesting is in the logistical problems of handling increased volumes of material in harvesting and transport sectors.

This manifests itself through the harvester's inability to cut large crops (quantity versus quality imperative) and the additional volume (a lower bulk density) of the harvested material reducing the mass of material carried by infield and subsequent rail or road transport to the mill. Whole-of-crop harvesting is the centrepiece of the New South Wales sugar industry's diversification into electricity cogeneration.

Whole-of-crop harvesting represents a major shift in technology requirements for harvesting and transport when compared to burnt or green sugarcane harvesting.

Mallee system

The purpose of the mallee harvester is to harvest short rotation woody crops. The prototype mallee harvester performs the basic functions of gathering, severing stems at ground level, feeding all the woody (trunks, stems, branches etc) and leafy biomass (foliage, leaves etc), through a chipper system and delivering the chipped product into infield transport. There is no debarking or separation of leafy biomass from woody biomass during the process.

The chipping process is an important step in the overall delivery process, as it converts the mallee into the product received and increases bulk density, which acts to reduce transport costs.

The prototype mallee harvester has been developed around the characteristics of the mallee feedstock and the form of the tree. The issue to be considered in a system context is whether the product derived from whole tree harvesting is directly suitable for the supply chain objective or whether post processing of the material is required. The minimum level of post processing required is screening to remove the small proportion of the biomass that is oversize to improve the handling properties of the mass. For storage and stockpiling, the leaf, twigs and bark will need to be separated from the chip. The chip can be stored relatively easily in green form if it is clean, but the other fractions need to be dried before storage of more than a few days (see section 1.2.2). Integrated processing may be undertaken with each biomass fraction (leaf, bark, woodchip, and twig) allowing each to be allocated to their highest value product option.



Figure 2.3 Ex-harvester mallee biomass (left) and after screening (right).

The biomass in the left photo was produced by a drum chipper and the particles are relatively consistent in size. The biomass in the right photo was produced by a disc chipper, which tends to let more twigs pass through the chipper in long lengths. However drum chipper product still requires screening.

The current prototype mallee harvester can harvest single stems up to 15 cm diameter, and with multiple stemmed coppice mallees, it appears to be able to process heavier mallees because the smaller separate stems are easier to handle than large single stems. Where mallees have grown beyond this specification, particularly in the older WA mallee crops, alternative systems (e.g. feller/buncher or hand falling, and separate chipping operations) will be required to bring these stands under control.

2.1.5 Discussion

Whole-of-crop harvesting with all material (cane and trash) transported to the mill is the sugar system with the closest synergies with mallee harvesting operation. The challenge for sugarcane whole-of-crop harvesting is in the logistical problems of handling increased volumes of material in harvesting and transport sectors. Sugarcane harvester design elements have to be changed to meet the requirements for harvesting whole-of-crop when compared to green and burnt cane. The sugarcane whole-of-crop harvesting supply chain needs a clear supply chain objective of crystal sugar plus energy, energy only or sugar only.

Similarly the mallee supply chain objective will need to be clearly defined in terms of the product mix. The markets and products from mallee will be probably be multiple, as discussed in section 1.2.2 and Chapter 4. However it is unlikely that any separation of biomass into its fractions (wood chip, leaf, residues) will occur on the harvester as the fractions do not appear to be as readily separated as cane can be separated from trash. However for stockpiling and marketing purposes, separating wood

chip from the rest of the biomass appears likely to be the minimum requirement and market development will help inform where post-harvest upgrading should take place.

2.2 Design Considerations

Sugar system

During the last decade the harvesting sector has faced an unprecedented cost-price squeeze from rising capital, parts and fuel costs and labour availability. This has been compounded by a run of poor seasons which has impacted on harvester productivity.

The harvesting sector is responding to these issues through a number of alternative design considerations to the standard Australian machine. These include modifications to suit a number of row spacings and wide-swath harvesting.

Sugarcane harvesting is undertaken over a relatively long period (June to December), across a large geographic area (sub-tropics, dry-tropics, wet-tropics, varied soil types) along a narrow coastal strip with rainfall averages above 1000 mm per year. Hence, it is inevitable that harvesting will be conducted during or after periods of wet-weather. To cater for this, the sugarcane harvester is available in tracked configuration.

2.2.1 Row Spacing

In conventional sugarcane farming systems, sugarcane is often grown on rows 1.5 m apart however there is significant variance, with large proportions of the crop in India, China and the traditional production areas in Brazil being on 1.0 m row spacing. The Case IH Austoft 7000 and 7700 cane harvesters have a wheel centre of 1860 mm and a track centre of 1880 mm respectively. Case IH 7000/7700 machines built prior to 2003 have a throat width of 900 mm. Machines built after 2003 have a throat width of 1080 mm. The Cameco (2500 series) and John Deere (3500 series) both have a wheel and track centre of 1880 mm. Cameco 2500 series have a throat width of 900 mm whilst, John Deere 3500 series machines have a throat width of 1000 mm. Therefore, current machinery is too much of an agronomic compromise for the current 1.5 m system (Figure 2.4).

A number of controlled traffic row spacings have been adopted throughout the Australian industry. There are a number of slight variations to these but the most common include 1.85 m wheel spacing with single row and dual row, 2 m wheel spacing with dual rows at 800 mm centres, 2.4 m wheel spacing with dual rows at 1200 mm and a 3 m wheel spacing with dual rows at 1.5 m spacing.

Figure 2.5 illustrates the 1.85 m wheel spacing configuration with dual rows. This spacing utilises current equipment and only requires minor modifications to the machines. Dual rows allow about a 23% increase in throughput at the same ground speed, however from an agronomic perspective the dual row at 500 mm is undesirable.

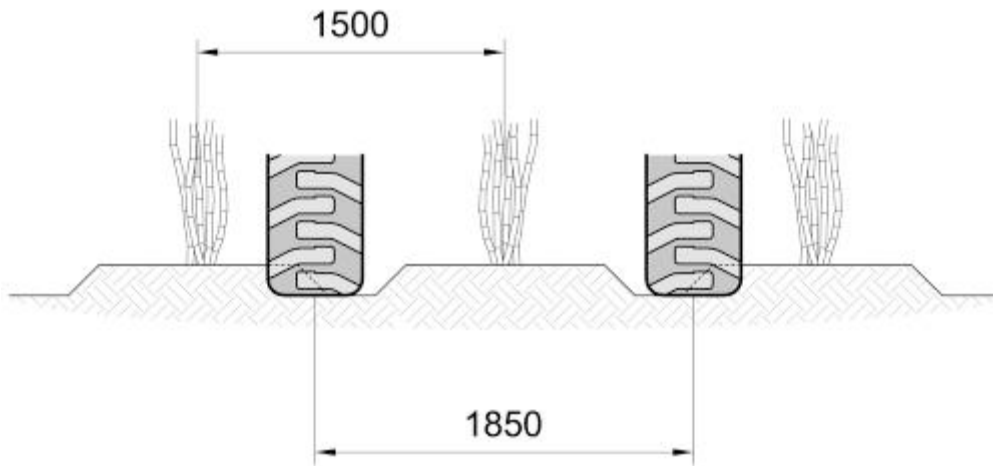

Figure 2.4 Wheel spacing 1.5 m row spacing – 1.85 m wheel spacing

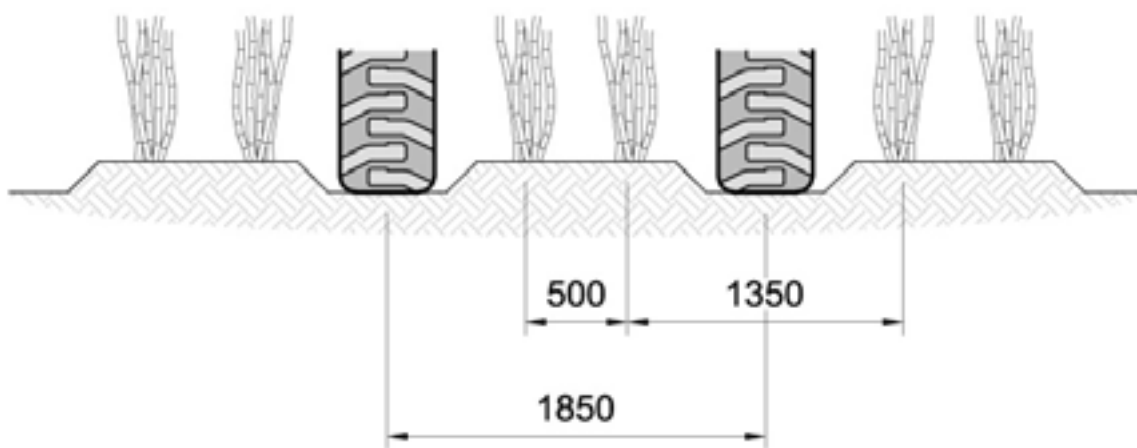

Figure 2.5 Wheel spacing: 1.85 m wheel spacing - dual row

The industry is moving towards a controlled traffic system and uniform row-spacing to increase production, reduce costs and remain competitive. However, the industry does not have a standardised row-spacing configuration as has happened in the cotton, vegetable and other industries both in Australia and overseas.

Mallee System

In the moisture limiting wheatbelt environment, row spacing is not a critical agronomic factor, in that a single row can exploit the moisture resources of the soil volume under a strip of land several metres wide. There is no agronomic advantage in spacing rows less than 3 metres apart, and current indications are that the most efficient row spacing may be much wider than 3 metres in a two row belt (Peck et al, 2011). Unfortunately some of the existing resource is planted on less than 2 metre row spacings and it is anticipated that these will not be harvestable unless some rows are removed.

A row spacing of 3 metres or more will accommodate harvesters and haulouts 2.5 - 3 metres wide over the outside of the tyres or tracks. Wider machinery wheel spacing would be undesirable as it

would require specialised floats for machinery transport and possibly escorts and subject to daylight hours only for road transport.

A plant spacing within the row of 2 metres offers a reasonable compromise between minimising the cost of establishing the crop (seedling costs and other costs are primarily determined by the length of row) and maintaining a consistent flow of material into the harvester. Larger spacings would make the feed to the chipper less consistent, even though mallee production per kilometre of row may not be affected by the larger intra-row spacing.

Because of the need to space rows widely and the flexibility available in intra-row spacing, there is no anticipation of needing to harvest two rows simultaneously. If higher plant density per kilometre of harvester travel is found to be desirable, it would be preferable to reduce the intra-row spacing in a single row, as this would improve the consistency of biomass flow into the harvester with a more continuous hedge-like structure in the crop and improve tree form from the harvesting perspective.

Multiple row (four rows and wider) belts and blocks are quite common at present, partly in anticipation of the rules that will define a carbon sequestration forest. When the mallees are harvested and the biomass is a commercial renewable energy resource, the definitions of carbon forests will become relatively less important as the carbon “credit” value will be reflected in the renewable energy market value of the biomass. The problems that arise with multiple rows are that:

- Inner rows are generally suppressed by competition within the mallee belt or block.
- When a crop’s outer rows are ready to harvest, the inner rows will still be too small for efficient harvesting as there is a limit to harvesting speed.
- In wide belts and blocks, inner rows may never reach harvestable yield in an economically realistic time (less than about ten years).
- The effect of inner row suppression becomes more apparent as the crop ages (Peck et al, 2011).
- The comparatively unproductive inner rows consume resources and reduce the growth of the outer rows, which increases the interval between harvests and the frequency of returns to the farmer.

Wide Swath

One of the few options available to the industry to reduce or maintain harvesting costs is to implement a system that can increase the delivery rate of cane – more cane delivered is more income for a relatively constant cost. In recent years, harvesters have reached the limit of increasing delivery rates, due to the capacity of the machines to harvest more cane, farm layout and transport constraints.

It is clear that if a harvester is able to cut a wider swath in each pass, it will increase the delivery rate of cane significantly and, therefore, contain the cost of harvesting. There are, however, some significant constraints to the adoption of wide-swath harvesting.

There are some significant constraints to the adoption of wide-swath harvesting. These include the lack of a factory-built production model 2-row machine, row-spacing configuration and associated issues, component specifications and set up, transport from field to factory, farming systems to suit wide-swath harvesting and industry acceptance, especially acceptance from growers.

John Deere are currently not manufacturing a double-row harvester for Australian row configurations (1.5 m, 1.8 m) because of the cost of manufacture. The factory production line produces one single-row harvester every 24 hours. Disruption to this product line when manufacturing a two-row harvester, which has a low market demand, increases the cost of production. However, this situation could change if there was sufficient demand for the product.

In Australia, there are a number of machine component configuration issues because there is no standard row width across the industry.

There is currently limited data on the interaction of wide-swath harvesting on the cane transport system and the effect that it has on the entire value chain. The mismatch of harvester output and the mill transport ability causes inefficiencies in the current system. The introduction of wide-swath, high-delivery-rate harvesting may impact negatively on existing mill transport infrastructure.

Mallee System

As discussed in the previous section, in mallee there appears to be little prospect of harvesting with a wide front as rows need to be relatively widely spaced in the water-limiting environment.

2.2.2 Machine size and configuration

The machine size and design concept affects various parts of the production and harvesting system. This includes;

- Establishment and layout of fields, to leave optimal access for manoeuvring of machinery.
- Space between the rows and turning circle space at the headlands for turning to enable the machine to return down the adjacent path to that just traversed.
- Harvesting patterns, for example travelling up one row then back down the next or working inwards from around the perimeter.
- Capital cost investment, which is usually high and therefore requires high annual hours of use to reduce the fixed machine costs per tonne or per hectare harvested.
- Operational costs
- Infield transport

2.2.2.1 Configuration

Sugar System

The configuration of the sugarcane harvester has evolved over the past 40 years from a harvester attachment side-mounted on a tractor to today's rigid, self-propelled, single row, over-the-row machine with a swinging elevator capable of delivering sugarcane to either side or to the rear of the harvester.

There are only three manufacturers of commercial 'chopped' sugarcane harvesters. These are John Deere, CNH and Santal. Until 2004, CNH had a manufacturing facility in Australia. Today all machines are manufactured in either the US (John Deere - Rest of the world machines) or Brazil (John Deere Brazil machines and CNH) and imported. Santal provides machines for Brazil only.

Mallee System

In order to fast-track the development of the prototype, existing suitable platform vehicles to power and drive the harvester were reviewed. Vehicles ranged from front-end loaders to forage harvesters and utility tractors. This approach also maximised the investment time and money for the development of a harvester head arrangement.

Based on this study, a Claas Xerion utility tractor was chosen as the platform vehicle. No modifications are required to this tractor. The harvester head is a single row, over-the-row arrangement which attaches to the rear of the tractor via three-point linkage.

Manoeuvrability and associated soil compaction issues will need to be considered in the selection of the propulsion system (tracked or wheeled configuration) of the platform vehicle. It is probable that the next prototype will be an articulated machine, with the weight of the head carried on its own axle, and the cab and power pack carried on the second driven axle. A relatively long articulated machine is anticipated because:

- The mallees cannot be fed horizontally or inverted like cane under the cab, they are handled in a vertical orientation from the saw to the chipper. The compact design of the cane harvester cannot be emulated with mallee harvesting.
- If tracked, the machine must be as mobile as possible, so rubber tracks will be required. Rubber tracks have restricted load capacity and two pairs will be required to carry the weight of the harvester.

2.2.2.2 Weight

Sugar System

The Australian ‘chopped cane’ sugarcane harvester is around 15 tonne to 20 tonne depending on make and model. For example the weight of a John Deere 3510 series harvester is 19 tonne for a tracked machine and 15.4 tonne for a wheeled machine.

In areas of high labour costs (e.g. Australia), very high machine output is critical to reduce costs and so a heavy machine is inevitable.

The weight of the machine and footprint area of tyres or tracks has a significant impact on soil compaction. To address this issue, the Australian industry is adopting various controlled traffic row spacings.

Mallee System

The net weight of the Claas Xerion is about 13 tonne depending on specification. However, it can handle up to 23 tonne (max. 50 km/hr) and 36 tonne (up to 10 km/hr) of extra ballast for infield operation. The weight of the mallee harvester attachment head is about 5 tonne.

The Xerion is an effective vehicle for the prototype harvester, but the next and subsequent prototypes will probably be purpose-built. It does appear that these machines will be of a similar weight to cane harvesters, but possibly heavier. The perpetual labour shortages in the wheatbelt and strong competition for labour from the mining sector suggest that plant operators will need to be well paid and heavy, high throughput machinery will be essential.

Flotation will become a significant issue for harvesters and haulouts as a bioenergy crop will need to provide as close to year-round supply as possible. For much of the year, soil conditions will be favourable, but the predominantly winter wet season commonly causes perched water tables and unstable clay subsoils. Soil conditions along the tree belts may be improved by the mallee root mat, but harvester and haulout access to the belts may necessitate crossing water-logged areas and creeks. The presence of low sharp mallee stumps may make high flotation tyres impractical, and steel tracks will reduce the essential mobility required for a dispersed resource. Consideration is being given to the use of rubber tracked machinery.

Damage to farm cropping soils in the vicinity of the mallee belts is also a consideration with the integration of mallees into the wheat paddocks. Controlled traffic will be essential for harvesters and haulouts, both for the actual harvesting and for transport of machines and biomass around the paddocks.

2.2.2.3 Engine Size

Sugar System

The John Deere 3500 series harvester have an engine power output of 337 Hp (251 kW) at 2100 rpm (JD8061H 8.1L) with an option to increase power to 375 Hp. The Case IH 7000 series machines have an engine power output of 355 Hp (261 kW).

The high power availability and hence high fuel usage demand high productivity. This translates into high machine pour rates. In addition, high parasitic losses (e.g. cooling losses, component no load power consumption) reduce overall machine efficiency. Improved machine component-crop interaction (e.g. improved feeding) and minimising weight can reduce the need for high power requirements.

Mallee system

Energy inputs for chipping are high due to the high wood density (750 to 850 dry kg/m³). The Claas Xerion has an engine power output of 357 Hp at 1800 rpm (six-cylinder CAT C-9 8.8L). As the chipping system requires high and constant speeds, the harvester attachment is driven by the rear PTO and requires almost all the rated PTO power of 303 Hp at 1800 rpm.

The performance of the prototype mallee harvester is limited by available power. Increased power will be required to provide economically viable pour rates, possibly in the vicinity of 500 kW, with most of that power required by the chipper.

2.2.2.4 In field transport

Mallee system

Mallees are a dispersed resource, with harvest yields typically of about 1 -2 green tonnes per paddock hectare (though yields will be about 60 green tonnes per belt hectare). This low harvest yield means infield transport will be over relatively long distances, so haulout capacity will need to be large and speeds will need to be as high as possible.

In addition, it appears unlikely that the biomass can be tipped from bin to bin, as is common in cane, because the tipping action will reduce the bulk density of the loads, and trucks will be limited by volume rather than weight. Considering the long road haul distances, this loss of bulk density is also unacceptable.

Due to this combination of factors, it is probable that haulouts will need to be at least 25 tonne capacity and about 70 cubic metres in volume, so that loads can be transferred from vehicle to vehicle undisturbed within the containers that are filled by the harvester. Large haulouts could become another driver for high pour rates from the harvester, as these large capital-intensive machines will demand a high flow to dilute their costs. High harvester pour rates necessitate heavier mallee crops, and increasingly push the harvester itself towards higher power and increasingly heavy robust design.

2.2.3 Discussion

The sugarcane industry does not have a uniform row spacing and standardised row-spacing configuration. Furthermore current sugarcane harvesting equipment has a detrimental agronomic impact on current 1.5 m row spacing systems. The industry is thus moving towards a controlled traffic system which will also control the impact of harvesting equipment on soil compaction.

Sugarcane and the current prototype mallee harvesters have similar mass and engine power as indicated in table 2.1 below. However future mallee harvesters will need about twice as much power and if tracked, they will need two pairs of tracks, which will add to the weight of undercarriage

components. The pressure to increase harvester pour rate will also necessitate a more robust machine, adding further weight.

Similar “systems-thinking” and integrated harvester/soil/crop solutions will be required for the mallee harvester and infield machinery configurations. High harvester output is critical to reduce costs per tonne of biomass while minimising impact on the mallee plant coppice and adjacent production areas.

Table 2.1 Harvester Comparison Table

Parameter	Sugarcane Harvester*	Current prototype Mallee Harvester	Future prototype mallee harvester
Row Configuration	Single row, over-the-row	Single row, over-the-row	Single row, over-the-row
Mass	19 t/15.4 t Tracked/Wheeled	18 t Wheeled	>20 t articulated tracked
Engine Power	251/337 kW/Hp	266/357 kW/Hp	>500 kW

*John Deere 3500 series

2.3 Machine Performance

An important step in the design process is to define the machine dependent parameters which characterise the machine performance envelope. It is against these parameters that the product can be validated to ensure that it meets specifications and that it fulfils its intended purpose.

The key machine design parameters which exert a significant influence on the productivity, quality and sustainability of the harvesting system comprise: the quality of the cut, pour rate, bulk density, product quality and fuel consumption.

2.3.1 Quality of Cut

Quality of the cutting is an extremely important factor influencing post-harvest quality and regeneration of the shoots produced from the cut stumps of the previous crop.

Sugar System

The first year's crop is called plant cane and is harvested a year or more after planting. New roots and shoots are regenerated each year from nodal bands on the plant cane stool and in succeeding years, these are harvested as ratoon crops.

Sugarcane stalk is a naturally occurring cellular material with engineering properties that vary throughout its cross-section. There are two main components of interest in the stalk cross-section, the outer rind and the near saturated fibro-porous core. The rind possesses hard and brittle engineering properties, whilst the centre is less fibrous. Fibres run longitudinally along the stalk and converge in nodal regions where the stalk is more brittle and densely packed with fibres.

The basecutters sever the cane stalk at or below ground level and assist in feeding the stalk, butt-first, into the feed train. The basecutting process interacts with the soil, the stool and the harvested stalk. The level of damage to the stool associated with the cutting process is an important performance criteria as this impacts on yield of the ratoon crop.

Much research has been undertaken on the relationships between various basecutter parameters and the severity of damage and failure modes of stalks during the basecutting process. Henkel et al. (1979), Ridge and Dick (1988), Garson (1992), Ridge and Linedale (1997), Kroes and Harris (1994), Kroes (1997), DaCuhna Mello and Harris (2000), Crook et al. (1999) and Davis and Norris (2001) have identified cultural, operational and design features as affecting soil levels in the cane supply and basecutter interaction with the crop in an attempt to quantify the level of damage and juice loss occurring in the base cutting process.

On the majority of industry-standard harvesters, the basecutters rotate at a fixed rotational speed. The forward speed at which modern harvesters are able to harvest current crop sizes have increased concurrently with the increase in available engine power. A typical 100 tonne/ha standing crop would be harvested at about 9 km/hr.

For a given ground speed, an overly high basecutter rpm will result in stool being cut by the blades multiple times. When the basecutter rotational speed is too slow for the forward speed, then a tearing cut results and stalks are torn off by the disc before a blade reaches the stalk. This causes severe damage to the stool.

Kroes and Harris (1994) found that a major cause of damage to the cane is contact between the basecutter disk and the stalk prior to the completion of the cut. Cane damage due to disk contact is attributed to excessive harvester ground speeds or feed rates.

The billeting system (chopper box) is required to chop a cane stalk and trash mat, up to 250 mm thick into lengths generally between 150 mm and 250 mm.

The rotary pinch-chop concept for the billeting of cane is the system in use in all production chopper harvesters. Rotary-pinch chopping systems consist of two machined contra-rotating drums with hardened steel replaceable blades (three or four blades per drum equi-spaced around the circumference) mounted parallel to the axis of the drums so as to pinch and sever material passing between the drums.

Even though a considerable amount of time have been undertaken on redesigning the chopper system, the primary focus of the designs has been on maintenance and reliability, with little emphasis on increasing the quality of the cut.

Norris et al. (1999) quantified that losses up to 9% can occur in the billeting process and that machine design and operation can significantly impact on the magnitude of these losses.

The most appropriate way to quantify billeting losses is in percentage loss per cut per metre (% loss/cut/metre). That is, a 330 mm billet has 3 cuts per metre, whereas a 100 mm billet has 10 cuts per metre.

The percentage loss per cut per metre (%/cut/m) will range from:

- a minimum of 0.6% for new blades, pour rate < 120 tonne/hr and billet length > 2 nodes, to;
- greater than 1.5 % for high pour rates, worn blades and shorter billet lengths.

Mallee system

The quality of cut may be less important in trees cultivated for biomass where the supply chain objective is a material suitable for burning when compared to other cultivated agricultural crops.

Nevertheless, the quality of cut may impact on the coppice or regrowth that grows from dormant buds under the bark of the cut stumps.

The mallee harvester principle is to use a heavy disc saw to cut the base of the mallee stems and in many instances this will also skim the top off the lignotuber from which the stems sprout (Figure 2.6). Sawing is a process that involves many small cuts rather than a single blow by a knife as in the case of a canecane base cutter.

The quality of the cut by the saw is a factor for the regeneration of the crop, as a clean cut without shattering the stump will reduce the opportunity for disease, and in young mallees a clean cut will minimise the risk of uprooting the lignotuber. The mallees are also relatively strong, and at some point the forces of saw impact may also become a matter of harvester durability, especially after several harvests when the lignotuber and root system have become quite large.



Figure 2.6 The top of a mallee lignotuber removed by the harvester's saw (above) and the condition of the site with cleanly cut stumps after passage of the harvester (right)

It is anticipated that harvest speed will be restricted to less than about 4 km/hr to control the size of each saw-tooth's cut, maintain an acceptable level of impact force, and to allow the harvester to be directed onto the mallee stump without excessive lateral forces on the harvester's head or the mallees.

Processing the harvested mallees through the chipper is a complex process of passing very sharp knives, working against a fixed anvil, through strong wood at specific angles to the fibres of the wood. The process of chip formation involves both cutting of the fibres, and equally importantly, the splitting of chips behind the knife which allows the knife to continue its passage through the wood. Knife sharpness is critical and when knives lose their edge, even before they appear blunt to the naked eye, there will be a significant increase in the specific energy of chipping and reduced the capacity of the chipper to feed itself. Forestry chippers typically have a knife change about once a shift. The angle of grind on the knives is also a critical issue, so knives are normally removed and reground with specialised workshop machinery. The angle of knife impact upon the wood also needs to be within a narrow range to ensure chip quality is maintained and specific energy is minimised.

While bioenergy feedstock is a less demanding product than pulp wood chip in terms of quality of chip, many of the chip quality issues arising from chipper design and maintenance also impact directly upon chipper efficiency, and operating the chipper accounts for a significant proportion of the diesel used throughout the biomass supply chain (Wu et al, 2008).

The quality of cut by the chipper also impacts upon bulk density. At the extreme in terms of poor cutting, shredding of whole trees is commonly observed to produce a very low density product with a

high proportion of long pieces, which also makes material handling more difficult. Within chippers, disc chippers do not process shrubby material and small whole trees as effectively as drum chippers because of the way in which the knives approach the biomass (whereas disc chipping is the preferred method in log chipping). Chipper knife-to-anvil clearance is another variable that affects both chip quality and material handling properties.

2.3.2 Pour Rate

Pour rate is an important performance measure in any harvesting system.

Sugar System

For sugarcane harvesting there are four different pour rate definitions commonly used. These include:

Instantaneous pour rate: Instantaneous pour rate is defined as how fast cane flows through the machine and is measured in tonnes per hour. Instantaneous pour rate is taken as the product of crop size and harvester forward speed, equating to the average instantaneous processing rate of the harvester. Instantaneous pour rate is difficult to measure and only used in research trials. The maximum instantaneous pour rate of a cane harvester is around 400 tonne/hr.

Elevator pour rate: Elevator pour rate is the tonnes per hour delivered off the end of the elevator while the machine is continuously harvesting. The elevator pour rate in the Australian sugar industry is around 100 to 150 tonne/hr in green cane.

Delivery rate: Delivery rate is the tonnes delivered to the mill delivery point per harvesting hour. A clear distinction is made between elevator pour rate and delivery rate. Elevator pour rate is the instantaneous rate at which cane is leaving the elevator while the harvester is continuously cutting and is not the average delivery rate of the machine. For example, a harvester travelling at 7 km/hr in a 100 tonne/ha crop has an elevator pour rate of 105 tonne per harvesting hour. After turning, waiting and other delay time is accounted for, this operation might deliver cane to the receival point at 60 tonne per harvesting hour. This is the difference between elevator pour rate and delivery rate. The typical delivery rate in the Australian sugar industry is around 60-80 tonne/hr in green cane.

Field efficiency: Field efficiency is the time spent harvesting divided by the total time spent on harvest activities. In the example above, with 105 tonne/hr elevator pour rate and a 60 tonne/hr delivery rate, field efficiency would be 57%

Engine hour pour rate: Engine hour pour rate is defined as the tonnes processed per harvester engine operating hour and is not to be confused with instantaneous, elevator or delivery pour rate. This method of measurement does not account for servicing and repair time and other harvest activities occurring when the harvester is not operating. It is an often used comparison as engine hours are easily measured.

A very high degree of variability can be expected in the field. Identical harvesters can have dramatically different harvesting rates under identical field conditions, depending on the operators priorities, time pressures etc. Figure 2.7 illustrates the delivery rate of a sugarcane harvester for various crop sizes. Even with the same operator and machine, harvesting rate is not solely dependent on crop size, as a 100 tonne/ha badly lodged cane can have a dramatically lower maximum harvesting rate than a 170 tonne/ha crop of standing cane. The differences in productivity between green and burnt cane are well documented.

Burnt crops are accepted as the easiest crops to harvest. Even older machines are able to achieve ground speeds equating to high pour rates, providing the cane is not excessively lodged.

Up to crop sizes of 80 tonne/ha there is usually little difference in the expected pour rates for modern harvesters between burnt and unburnt crops because pour rate is limited by maximum ground speed. As crop size increases, the difference in productivity between the two harvesting modes increases.

Initially, the reduction in productivity is because of restrictions on cleaning system performance (product quality issues). Visibility, difficulty in assessing position on the row and basecutter height control issues also impact on the speed at which the operator is comfortable. As the crop size continues to increase, maintaining effective feed becomes the major issue, resulting in stool damage and increased levels of damaged billets in the cane supply.

Australian data indicates that typical daily productivity in an unburnt crop of 180-190 tonne/ha is 40% of that in burnt cane and about 85% in 130 tonne/ha crops (Davis et al. 2000).

For whole-of-crop harvesting because there is no, or limited, cleaning being undertaken on the machine, the delivery rate becomes limited primarily by machine volumetric capacity. The evenness of feed (which dramatically impacts on cleaning system performance) becomes much less significant as crop size increases.

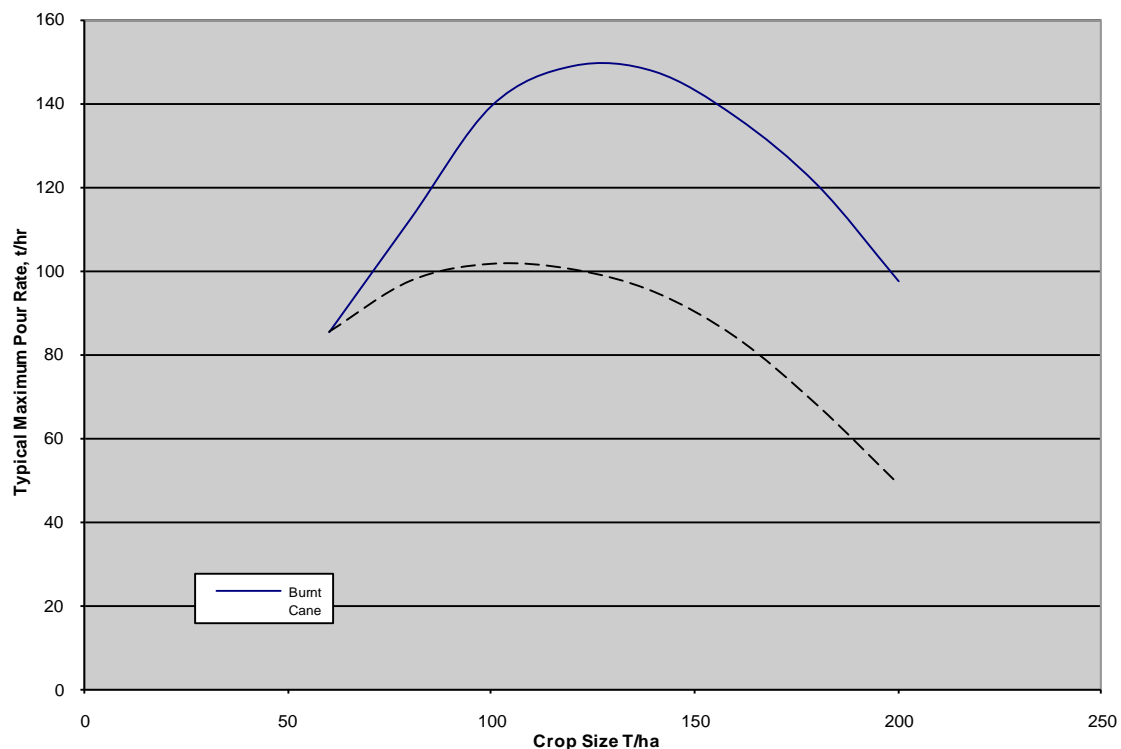

Figure 2.7 Effect of crop size on maximum harvester (tracked machines) delivery rate in burnt and green cane

In small crops, delivery rate is typically limited by maximum forward speed, however as crop size increases, a range of other factors control the typical maximum delivery rates.

Mallee System

Pour rate is a key performance indicator in the development of a mallee chipper harvester. System analysis (McCormack et al. 2009) indicates that the most efficient instantaneous pour rate for reliably harvesting mallee should exceed 50 green tonnes /hr.

The FFI CRC project, with the current harvester, has a target instantaneous pour rate of more than 20 green tonnes/hr. The target beyond the current project is between 60 to 80 green tonnes /hr with a

subsequent prototype harvester. The prototype harvester in trials to date has achieved a maximum continuous pour rate of 35 green tonnes/hr in a mallee crop yielding about 12 green tonnes/km of row (about 35 green tonnes/ha). Performance in heavier crops demonstrated a similar decline to that illustrated in Figure 2.7 due primarily to the heavier trees overloading the chipper (due to lack of power) and reducing the continuous performance of the harvester.

In principle, higher pour rates would result in lower per tonne costs but with the restriction of a relatively low harvester speed, at some point the mallees will need to be so big that the over-the-row chipper harvesting method may become impractical. At this stage it is not possible to identify the limit of performance.

2.3.3 Product bulk density

The bulk density of the product produced is an important performance consideration for efficient transport.

Sugar System

The most critical crop factors affecting bulk density of the cane-trash mixture are stalk density, leaf and trash to cane ratios and leaf and trash characteristics.

The ratio of trash and leaf to cane is generally accepted to be affected by variety, growing conditions and final crop yield. A given variety can display significantly different characteristics, depending on the environment in which it is grown.

In an assessment of the transport logistics, the breakdown of the characteristics of the total biomass is of critical importance, i.e. extraneous matter (EM) levels alone are of limited value unless the components of the EM are known. Extraneous matter is defined as any material other than clean billets that occurs within the homogenous mixture of harvested biomass that is processed at the mill.

Available data on the composition of residues, with respect to fresh moisture content, are summarised in Table 2.2.

Table 2.2 Cane supply composition (wet and dry matter basis)

Component	% by weight		% by moisture		% DM of total EM	
	NSWSMC	NSWSMC	NSWSMC	NSWSMC	NSWSMC	NSWSMC
	1999	2000	1999	2000	1999	2000
Cane	80.2	71.5	-	-	-	-
Tops	3.6	-	78.6	84.6	7.7	10.6
Green Leaf	10.1	28.5	66.9	67.9	33.4	36.2
Dry Leaf	6.1	-	3.5	17.0	58.9	53.2

This data indicates that, although green leaf is the greatest component by mass of EM, dry leaf is a significantly greater source of dry-matter.

New South Wales Sugar Milling Cooperative (NSWSMC) modelling and actual data indicates that bulk densities of 0.250 tonne/m³ or greater are required for a sustainable harvest and transport system for whole-of-crop harvesting (Beattie et al. 2006).

Figure 2.8 shows the bulk densities achieved in a number of different trials conducted by NSWSMC with whole-cane and unshredded trash. In a number of the trials, one variable was altered to assess its impact on bulk density of the product. These data show that the average bulk density of whole-of-crop harvesting is about 0.20 tonne/m³. Of concern is the significant number of bulk densities near or below 0.20 tonne/m³.

Table 2.3 shows the typical bulk density for various cane supply.

The major issue is the low bulk density of the cane/trash product leaving the harvester. Addressing this by increasing the bulk density of the mixed product reduces the number of infield haulout bins, removes the necessity to have additional people and machinery at the cane pad for bin levelling and reduces road transport costs to the mill.

For NSWSMC, increasing bulk density through a reduction in billet length is not that simple. A balance needs to be found between short billet lengths and sugar losses and deterioration and compare this to other alternatives like chopping of the trash to improve packing in the infield and road transport bins.

For sugarcane, a low bulk density has transport cost implications, due to true cartage charges being on a 'per bin' basis rather than a 'per tonne' basis.

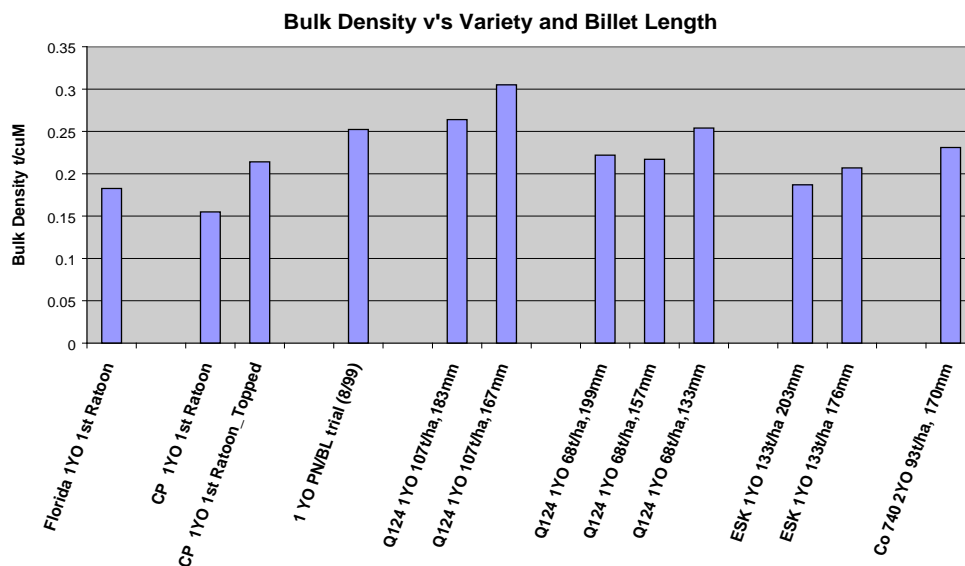

Figure 2.8 Bulk densities of whole-cane

Table 2.3 Bulk density of cane supply

Product	EM	Bulk Density
	%	t/m ³
Burnt Cane	6	380
Green Cane	12	340
Whole-Cane	25	200
Shredded Trash and cane	25	240

Mallee System

As a bulk material, the biomass must flow as well as possible. This means minimising the proportion of long pieces such as twigs, sticks, and the long slivers that can be produced from larger wood sections (Mattsson and Kofman, 2002). Wood chipping is seen as the most suitable method of comminution as it produces a flowable material with an acceptable level of whole twigs and small sticks (Giles and Harris, 2003).

There is limited data on the bulk density of product from the mallee harvester as it has undergone limited infield trials. However, densities of about 400kg/m³ have been measured in 10 tonne body trucks after transport. However, it is likely that this product was compacted during transport.

Mallee biomass loaded into conventional chip trucks has seen full mass loads achieved when loaded by a chipper (see Figure 2.9) which indicates load densities of over 350 kg/m³.



Figure 2.9 Loading a chip truck with mallee biomass using a roadside chipper

Bulk density will be a key consideration in the efficiency of infield and road transport. Therefore, if the load was sufficiently fluffed up by tipping, then transport efficiency will be affected.

Due to the small proportion of particles that are long, and the flat shapes of the chip and leaf particles, it is probable that tipping from bin to bin will agitate the material and reduce the bulk density. It is

known that tipping sugarcane billets from bin to bin in side-tipping sugarcane haulouts reduces the bulk density of the product after transfer.

The effect of product composition on bulk density is not known. It is hypothesised that leaf may increase the bulk density in an undisturbed sample because they are quite dense and could potentially fill the voids between the wood chips. The fact that chip trucks achieve similar mass loads whether loaded with clean chip or whole tree biomass suggests that the foliage and residues have little impact on bulk density within the ranges of biomass composition observed during trials, such as the one illustrated in Figure 2.9.

Wood chippers are also known to achieve some packing when the particles are thrown out of a chute rather than allowed to tumble off the end of an elevator. Therefore, one strategy to avoid reducing bulk density may be to fill bins and then handle and transport the bins from the harvester to the destination without tipping to avoid agitating the product.

The bulk density of product in large capacity infield transport, after transfer onto road transport or at the final destination point has not been determined. Data on material bulk density should be collected when the harvester commences full scale infield trials.

2.3.4 Product quality

For agricultural commodities with no post-harvest processing, a clean wholesome product is of primary importance in marketing. Losses in quality are thus evidenced by a decrease in the market value of the product.

For agricultural produce which are subject to post-harvest processing, the aim is to maintain or enhance the quality of the products and make it readily marketable. Higher product quality after harvest will lead to lower processing costs, better quality processed products and thereby maximising the value of the product.

Sugar System

Sugarcane is a perishable commodity and must be processed into sugar quickly after it is harvested otherwise its commercial value deteriorates. Australian sugarcane mills organise their railway scheduling to ensure that most harvested cane is crushed within 12-16 hours of harvesting, with only a small proportion crushed 16-24 hours after harvesting. All cane is crushed within 24 hours of harvesting unless there is a temporary transport problem (Dawson, 2004).

Cane supply quality (high extraneous matter) and post-harvest sucrose losses are linked with low sugar recovery and several problems during sugar processing.

Post-harvest sucrose losses can be attributed to bio-deterioration which is associated with the inordinate delays between harvest to milling and aggravated by many intrinsic and extrinsic factors causing enormous depreciation in cane tonnage as well as sugar recovery. Besides harvest-to-mill delays, other factors such as ambient temperature, humidity, cane variety, period of storage, activities of invertases and maturity status are responsible for a decline in sugar recovery. The activity of invertases and proliferation of acid, ethanol and polysaccharides (dextran) producing microbes play a crucial role in the loss of recoverable sugars in cane and milled juice. In addition to loss in sugar recovery, its adverse affects has been noticed in the sugar manufacturing process and sucrose quality.

If a single product, sugar, is the supply-chain objective, only the millable cane is of interest and not extraneous matter. Millable cane is the sound stalk below the growing point of the plant. This includes suckers but excludes dead and rotten cane. Extraneous matter is anything that is not millable cane. Extraneous matter includes trash, tops, roots and soil. If other additional products are the supply-chain objective (e.g. electricity, ethanol), then both millable cane and EM components (trash) are of interest.

The components of an extraneous matter analysis are defined as:

Clean cane: pieces (termed ‘billets’) of cane without any adhering trash.

Trash: leaf material, dry or green.

Tops: the growing point of the cane plant; generally begins from the last node of the plant.

Suckers: a somewhat subjective measure. Suckers are immature cane plants, and generally occur within a mature sugarcane crop as next year’s crop begins to grow. In their advanced stage, suckers are characterised by their whitish colour and large diameter; when immature, suckers resemble tops.

Stool: any piece of harvested cane that has roots and dirt as the majority of its weight; the lower subterranean section of the cane plant.

Foreign material: material that is not of interest in the analysis of harvested components. Examples are a basecutter blade, wheel nut or plant material of non-cane origin.

Dirt: loose material left over after all other components of the analysis have been removed.

There has been considerable debate about the cost of extraneous matter to the Australian sugar industry in recent years. Opinions are split as to whether it is worthwhile expending effort to reduce extraneous matter; whether extraneous matter should be reduced at the harvesting stage, separated at the factory, or processed with the cane; and whether benefits can be realised from the collection or processing of extraneous matter.

Reduced extraneous matter levels result in higher bin weight, higher ccs, higher crushing rate, lower final bagasse moisture content and higher mixed juice purity. These factors minimise transport and milling costs and ensure the economic viability of the harvester sector.

Cane quality is extremely difficult to measure. It is hard to get a sample of cane that is representative of the larger lot of cane. Manually sorting and analysing samples of cane is time consuming and expensive.

NIR is a system that offers continuous real-time assessment of cane quality. The instrument takes an infra-red fingerprint of the cane as it flows into the mill. NIR accurately calculates fibre content of each individual rake of cane. Other cane quality measurements may be derived from NIR, such as extraneous matter, ash, pol and brix. Table 2.4 illustrates typical EM levels in the cane supply per biomass weight. The most variable component of EM is trash. The percentage of trash in the cane supply is dependent of crop conditions (e.g. lodged), weather (e.g. wet v dry) and harvester operational setting (e.g. fan speed). Trash levels can vary up to 20% of the total biomass weight.

Table 2.4 EM levels in cane supply

Cane Supply	Percent	Percent	Percent
Component	Biomass Weight	Biomass Weight	Biomass Weight
	SRDC (2006)	SRDC (2004)	Whiteing (2001)
Clean Cane	90.4	87	89.4
Tops	4	5.0	5.0
Trash	5	6.5	4.8
Dirt	0.6	1.5	0.8

Mallee System

Product specifications for woody biomass are most likely less when compared to other agricultural commodities. Lower chip specifications are acceptable for energy or oil utilisation. However, chipping of whole trees introduces other considerations, particularly the production of long particles such as sections of small branches, which add significantly to the difficulty of handling the bulk biomass (McCormack et al. 2009).

The chipped biomass in its unsorted state is a mixture of wood chip, leaf, and residues of assorted fines, bark and small twigs (see section 1.2.1 for more detail). The proportions of wood, leaf and residues is about one third each, but these values vary widely according to tree species and age at harvest. Younger, smaller trees have high proportions of leaf and less wood, and the proportion of wood increases with age (Peck et al, 2011). The leaf proportion also declines with increasing competition between mallees as the leaf area is regulated by the availability of soil moisture, so mallees grown in blocks rather than belts can be expected to have higher proportions of wood. However higher proportions of any one component does not equate to higher yields – the most important factor remains to maximise productivity because in most instances this will increase the per hectare yield of all constituents of the biomass.

It is expected that mineral content other than traces of dust will be minimal as the trees don't touch the ground with chipper harvesting and the saw works at least 50 mm above ground level. The harvesting head of the current prototype is attached on the tractor's three point linkage and supported by wheels to maintain its position above the ground, and future harvesters will also be designed to avoid contact of the ground by the saw.

The size and shape of the chips will also impact on the bulk density of the material. The size and shape of the chips is known to vary with the chipper's linear feed rate as this determines the length of fibre in each chip, and chip length and thickness are positively correlated.

The product is not perishable over periods of a few days but the impact of this product composition on spoilage should be investigated. It is known from the forest industries that clean chip, properly stacked, can be stored for extended periods, but the leaf and other fine materials, either alone or mixed with the chip, will cause stack heating, decomposition, and potentially result in fire. Fine materials will need to be dried prior to storage for more than about a week.

2.3.5 Fuel consumption

Sugar System

Typically, harvester fuel usage is expressed as fuel used, divided by the total tonnes cut over an extended period. A potentially more useful approach is to calculate fuel efficiency as the harvester operates. However, simple calculations of estimated operating fuel consumption versus pour rate result in very low fuel usage figures per tonne harvested, which the industry would consider nonsensically low. The discrepancy is primarily because of the percentage of time the engine is operating but the harvester is not actually processing cane, e.g. when turning at ends of rows, waiting for haulouts with the engine operating etc.

The engine size of harvesters has increased from about 240 Hp (176 kW) in the early 1990's up to 375 Hp (275 kW) in today's models.

The high power availability and hence high fuel usage demand high productivity. This translates into high machine pour rates. In addition, high parasitic losses (e.g. cooling losses, component no load power consumption) reduce overall machine efficiency. Improved machine component-crop interaction (e.g. improved feeding) and minimising weight can reduce the need for high power requirements.

The field efficiency or the time sugarcane harvesters are actually processing cane is about 50% of the engine operating hours. Further data on field efficiency is can be found in Section 2.4.3

When turning at ends of rows or for short waits for haulouts, operators typically maintain the engine at full power setting, and throttle back for extended periods when waiting for bins etc. Clearly, factors such as row length, haulout waiting time and a range of external factors dramatically impact on fuel consumption/tonne harvested.

Instantaneous fuel consumption allows realistic estimates of *relative* fuel consumption as key factors such as harvesting mode (burnt, green, shredding and whole-crop) crop size and pour rates change.

Willcox et al. (2004) measured the average harvester fuel usage under green cane and burnt cane conditions in the Maryborough, Mackay and Ingham regions in Queensland over a two year period. They measured total fuel used per day and divided it by the total tonnes cut for the day.

Table 2.5 shows the effect of crop yield on harvester fuel usage for green and burnt cane conditions. Harvesting crops green consume about 40% more fuel per tonne than harvesting burnt cane due to material processing and cleaning.

Whole-of-crop harvesting fuel consumption estimates are about 15-20% higher than required for burnt cane. The increased power to the choppers and basecutters is compensated for by the reduced power for the extractors (Norris et al. 2000).

NSWSMC has measured fuel usage of 0.89 L/tonne to 1.19 L/tonne in NSW two-year-old crops (*M Inderbitzin pers com 2010*).

Table 2.5 Effect of yield on harvester fuel use (Willcox 2004)

Crop Size T/Ha	Fuel use	Fuel Use
	Green Cane	Burnt Cane
	L/T	L/T
60	0.97	0.71
80	0.92	0.66
100	0.84	0.61
120	0.77	0.56
140	0.69	0.51

Mallee System

The fuel consumption of the mallee harvester under normal harvesting conditions is not as yet known.

2.3.6 Discussion

The quality of cut is very important in sugarcane harvesting. It is similarly important in the context of harvesting mallee to avoid stump damage by the saw and maintain chipper performance. The bulk density of the product produced is an important performance consideration for efficient transport. The bulk density of sugarcane can range from 380kg/m³ for burnt cane to as low as 200kg/m³ for whole-of-crop. The bulk density of chipped mallee is about 350kg/m³ to 400kg/m³. This should be verified across a range of operating and crop conditions in future harvester performance evaluations.

Cane supply quality (high extraneous matter) and post-harvest sucrose losses are intrinsically linked with low sugar recovery during sugar processing. The elevator pour rate in the Australian sugar industry is around 100-150 tonne/hr in green cane. This reduces to about 60-80 tonne/hr delivered. The prototype mallee harvester has achieved a continuous pour rate of around 35 green tonne/hr under trial conditions.

The fuel consumption of the mallee harvester should be measured to provide further data on harvesting performance and costs. A harvester capable of a pour rate above 60 green tonnes/hr is likely to have about 500 kW of installed power, so fuel efficiency is expected to be much less than for cane because the specific energy of chipping is relatively high. Chipper efficiency will be the topic of future research.

Table 2.6 Harvester performance comparison

Parameter	Sugarcane Harvester	Prototype Mallee Harvester
Pour Rate	100 green t/hr*	35 green t/hr
Product Bulk Density	250kg/m ³	400 kg/m ³
Fuel Consumption	0.9-0.1.2 L per whole-crop tonne	Unknown

*Elevator pour rate

2.4 Harvester Performance Monitoring

To ensure harvesting machines are suited to their operating conditions and crop characteristics they are working in, and are achieving optimum productivity their performance must be evaluated. Performance is a measure of some output or behaviour and is the first step to improving productivity. The information that is collected can help match appropriate machinery to site conditions and determine if machines are performing optimally.

2.4.1 Loss Processes

Sugar System

The process of harvesting sugarcane to produce a product low in or free of extraneous matter (EM) has always been accompanied by the loss of millable cane. This loss increased considerably with the change from whole-stalk to 'chopped cane' harvesting and has been exacerbated with the move into green-cane harvesting with the increased demand for removal of EM (Brotherton 2002).

There has always been an industry awareness of the cane loss problem, but the magnitude of losses has been hidden to a large extent by the invisible nature of the loss. That is, desiccated billets through the extractor fan are difficult to identify and cane and sugar loss is difficult to measure. Industry has demanded increased machine throughput, and this has, to some extent, overridden the effectiveness of measures to minimise cane loss in harvesting.

Harvesting losses occur throughout the harvesting process, from feeding and gathering through to chopping, cleaning and transferring to infield haulouts.

Whilst losses have generally been presented as cane loss, the loss of Pol (a sucrose approximation) and loss of CCS (recoverable commercial sugar) have become more relevant indicators in recent years as these are the intended products of the current industry. These parameters also respond to stalk degradation and deterioration that are omitted in cane loss.

Brotherton (2002) considered that an accurate, absolute magnitude of loss is necessary for economic evaluation of harvesting losses. The Australian sugar industry has invested significant resources in the assessment and measurement of losses during cane harvesting.

Table 2.7 shows the typical losses from various components of the harvester during harvesting.

Table 2.7 Typical cane losses during harvesting (SRDC, 2004)

Process	Losses	Losses
	Range, %	Average, %
Gathering	1-2	1.0
Basecutter	1-3	2.0
Feedtrain/Chopper	2-6	4.5
Extractor	3.5-15	9.0
Total	7.5-26	16.5

Mallee System

There is no quantitative data on losses during harvesting as the prototype harvester has not undergone commercial testing. The main loss processes would include gathering, chipping and spillage during transfer to the infield transport. As there is no separation of the product on the harvester, there are no losses from this process like in sugarcane harvesting.

Losses during gathering may include branches, twigs etc expelled during felling and feeding. The aim is to have minimal gathering losses as whole branches, limbs etc would need to be cleaned up to avoid contamination of neighbouring crops. This clean-up would add significantly to the cost of harvesting if it was a measurable quantity. There may also be losses of chip thrown out of the chipper mechanism.

It is likely that the losses as a percentage of harvested material will be insignificant, as shown in Figure 2.6 in section 2.3.1.

2.4.2 Real-time monitoring systems

Sugar System

The manufacturers approach to performance monitoring of sugarcane harvesters during harvesting has been to provide only the condition analysis of the mechanical components such as the engine and hydraulic circuitry. For example, engine hours, engine speed, oil temperature and hydraulic oil level, temperature and component pressures (chopper, basecutter, feed train) are available. The only condition reported on performance with respect to machine-crop interaction is basecutter height and primary extractor fan speed.

Measuring field and other variables affecting machine performance is necessary to encourage more efficient harvesting, reducing costs and increase industry profitability through reducing field losses of cane and juice during mechanical harvesting.

Hildebrand (2002) viewed recovery of any substantial loss of sugar in the field during harvest as being the most obvious and potentially the least costly economic gain available. Therefore, a major opportunity for the sugar industry is to significantly increase industry profitability without increased capital investment. This can be achieved by reducing field losses of cane and juice during mechanical harvesting. Adopting Harvesting Best Practice (HBP) with attention to extractor fan speed, pour rate, feed train and chopper speed synchronisation, basecutter height control and row profile, row length and cane presentation has two main outcomes. It increases the amount of cane delivered to mills and reduces the potential for environmental impacts associated with sugar juice entering waterways causing de-oxygenation (SRDC 2004).

Agnew (2002) reported that better and timelier feedback is vital to overcome the flawed harvester-payment system and enable negotiation of the best possible job at an acceptable price for individual blocks.

Various technologies have been researched and developed to provide machine performance feedback or automate machine operations to favour higher harvesting efficiency and higher sugar recovery. These include automatic basecutter height control, synchronising component speed with ground speed, cane loss monitoring, ground speed and pour rate monitoring, harvester efficiency and cane yield monitoring. The aim of these technologies is to optimise on-the-go, the interaction between machine components and the crop. This will transfer as much of the sugar standing in the field to the mill, whilst minimising extraneous matter (EM) and dirt in the cane supply.

Recent developments in harvester monitoring and performance have seen the mounting on harvesters of various system configurations, which incorporate sensors to allow the status of the machine to be

determined. These systems typically monitor elevator on/off and engine on/off and incorporate GPS to allow tracking and harvester 'state' to be defined.

Mallee System

The Claas Xerion has an onboard tractor management system that not only controls implements but can monitor all tractor functions. The on board management system monitors the following:

- Full machine monitoring
- Area meter
- Hour meter
- Total fuel consumption
- Fuel consumption per field
- Fuel consumption per job
- Job processing
- Engine monitoring

Hence, there is existing capability for measuring and monitoring a range of field and other variables affecting machine performance. In the current prototype, Biosystems Engineering has installed data logging capability and transducers to monitor oil pressures, rotational speeds and some oil flows to various components in the harvester head. The feed rate from the saw to the chipper is linked via programmable logic control to ground speed and chipper feed speed is linked to the speed of the chipper drum. It may be feasible in future harvesters to regulate ground speed according to the load on the chipper. Future harvesters and perhaps the haulouts, will be auto steered, to follow tree lines mapped at the time of crop establishment, or mapped by the harvester on first harvest. Continuous mass flow measurement should be possible at a point where the chipped biomass passes at high speed around a curve in the discharge chute, and this capability will assist with infield logistics and lead to yield mapping and improved growth monitoring and modelling.

2.4.3 Field Efficiency

Field efficiency of harvesting equipment can be calculated as the percentage of total operating time that the machine is actually harvesting.

Sugar System

In the case of sugarcane harvesting, the target output is the steady-state operating speed and is primarily determined by crop conditions. The percentage of available time the harvester is achieving its target output is primarily determined by time lost:

- turning at end of rows
- waiting for haulouts to take the harvested crop from the harvester
- waiting for mill delivery of empty bins
- servicing and repairs
- moving between fields
- "cutting in" to new fields where harvesting rate is slow because the harvester tows a reversing haulout directly behind it into the field
- choking of material in the harvester

Time lost turning obviously relates to both the time taken for the harvester and haulout to turn at the end of the row and achieve correct positioning to allow the harvesting process to re-commence. It is therefore effected by:

- maneuverability of the harvester and haulouts
- available space for this maneuvering (headland width)
- length of row and crop size, therefore affecting the number of turns which must be executed in daily allocated cutting.

Row length is outside the control of the harvesting contractor. Short rows decrease the efficiency of a harvesting operation significantly because turn time is fixed. That is, less time is spent cutting cane for each turn when row length is reduced.

Time lost waiting for haulouts relates to haulout capacity, speed of travel to the unloading node, unloading time and return time to near the harvester. This is therefore effected by:

- haulout speed, loaded and unloaded on both field headlands and formed roads
- distance to the delivery point
- unloading time at the delivery point

Field efficiencies are an important measurement in the analysis of harvest cost and harvest transport systems.

The Australian cane industry has developed methodologies for measuring field efficiency. These include electronic systems using on-board electronic measuring equipment, data loggers and GPS systems. The typical field efficiencies for various crop sizes are shown in Table 2.8. These data are aggregated from the Maryborough, Mackay and Burdekin regions.

Benchmarking of Australian harvesting operations has been by undertaken by Sandell and Agnew (2002) and Willcox (2004). Table 2.8 shows the percentage of time actually spent cutting cane from the total daily operation from two seasons in the Maryborough, Mackay and Burdekin regions. This shows that on average a little over 50% of the time the machine is actually cutting.

Table 2.8 Field efficiency for various crop sizes (Willcox, 2004)

Crop Size	Crop Size	Field Efficiency
t/ha	t/km row*	%
60	10.8	53
80	14.4	52
100	18.0	52
120	21.6	52
140	25.2	51

*Assume 1.8m row width

Table 2.9 shows the average breakdown of operations across a 14-hour harvesting day from eight harvesters in the Mackay region. These data show that on turning at the end of rows and waiting for the mill to supply bins can consume nearly as much time as actual cutting time.

Table 2.9 Field efficiency for Australian harvesting (Sandell and Agnew, 2002)

Operation	Time (Hours:minutes)	% of Time
Cutting	6:15	45
Turning	2:50	20
Waiting for bins	2:42	20
Rest	0:59	7
Other Downtime	0:52	6
Servicing	0:22	3

Mallee System

The dispersed nature of the crop will have a significant impact on field efficiency. The yields per km of row will be about 20 to 40 green tonnes. However, because the mallees are in narrow dispersed belts, the yield per paddock hectare will be less than 5 green tonne per hectare, and typically around 1 green tonne per hectare. Therefore, the haul distance will vary from hundreds of metres to several kilometres, which will make the logistics of harvesting and infield transport critical to minimising the time lost by both harvesters and haulouts.

Modelling as part of this project has illustrated that because the rows of mallees are typically long, and the harvester's speed will be low, the 20% of time spent turning in sugar cane will be reduced to about 5% (see Section 7.3). With close coordination between the harvester and the haulouts to minimise waiting for bins, it appears possible that harvester utilisation in the vicinity of 70% - 80% may be achievable.

It is a challenging objective to achieve such high levels of utilisation in the mallee crop configuration, with the dispersed crop and capital intensive harvesters and haulouts. One option under consideration is to use infield transport for short hauls (up to about 2 km) to short-term landings in the corner of the paddock, and maintain the ratio of two haulouts per harvester. This will ensure that all three machines are as fully utilised as possible, with the emphasis upon maintaining harvester utilisation.

The paddock corner landings will in many cases not be accessible by conventional road transport prime movers, and it is proposed to establish road transport landings widely spaced across a district, perhaps at 10 - 20 km intervals. These road transport landings will be used for several days to weeks at a time while the surrounding farms are harvested. Transport between the paddock landings and the road transport landings will be by the addition of a third transport step, using a fast tractor or an 8x8 prime mover as a shunt truck to move one or two trailers at a time between the two types of landing.

In terms of logistics, coordination between harvester and the two infield haulouts will be in the order of minutes, maintained by relatively short haul distances. Coordination between the haulouts and the shunt will be in the order of hours, because the paddock landings provide a short term surge buffer. Coordination between the shunt truck and the road trucks will be in the order of days, with stockpiling at the road transport landings governed by the perishability of the biomass and the number of bins available.

There is no quantitative data on field efficiency as the prototype harvester has not undergone commercial testing and it is anticipated that another more powerful prototype will be required to conduct full scale commercial trials.

2.4.4 Discussion

Significant losses arise from mechanical harvesting of sugarcane. The majority of these losses are in billeting and separation of trash from billets. Recent developments in sugarcane harvester monitoring and performance have seen installation on harvesters of various sensors to allow the status of the machine to be determined. This has indicated that the percentage of time the sugarcane harvester is actually cutting cane is only around 50% of the total harvesting ‘shift’. Information on losses and field efficiencies from mallee harvesting is limited and will need consideration. Real time monitoring of the current prototype harvester will allow optimisation of performance.

Table 2.10 Harvester performance monitoring comparison

Parameter	Sugarcane Harvester	Mallee Harvester
Losses	7.5-26%	Unknown but indications are low
Real Time Monitoring	Increasing	Partial capability for prototyping; PLC and autosteer in commercial machines
Field Efficiency	50-55%	Unknown; >70% may be feasible

2.5 Harvest and Transport Integration

Harvest and transport sectors are often complex systems from a tactical and strategic planning perspective. Improved integration of harvest and transport can maximise efficiencies and profitability across these sectors, leading to reduced costs of production. In order to improve the system the key drivers and links must be developed.

2.5.1 Time of Harvest

Sugar system

Existing harvesting arrangements are based on interpretations of the commercial cane sugar (CCS) curve. The effect of harvest time on sugarcane productivity is a complex one. The Australian sugar milling region is spread across several varying geographic and climate zones. Across these regions and within regional districts varietal differences in cane yield and CCS vary throughout a harvest season. Typically, across the Industry, the harvest window tends to start in mid-June and finish by mid-November, with a season length of approximately 20-24 weeks. However, in NSW the season runs to mid-December often due to prolonged periods of wet-weather.

The increasing risk of rainfall-related harvest interruptions is a primary reason why industry is reluctant to have crushing seasons closer to the end of the calendar year. The extent to which rain stops harvesting depends not only on the amount of rain in any given period, but also on soil type, aspect, slope, temperature and the moisture content of the soil before the rain event. Rainfall is not uniform over a mill region and, therefore, harvesting interruptions to individual farms are also unpredictable.

The time of year when a crop is harvested affects yield by imposing both crop age and seasonal factors on the crop. The yield of the following ratoon crop is affected by the seasonal conditions into which the new crop grows.

McDonald, Wood and Muchow (1999) showed the importance of time of harvest and crop age on crop productivity and profitability. To fully understand the physiological effects of crop age and time of rationing on productivity, the effects of climate (temperature and radiation) on a well-managed crop (where no other factors limit growth) must be separated from other factors which limit growth.

Lawes et al. (2004) analyses suggested that exploitation of regional spatial variation would improve productivity. Sugarcane growers have a lot of issues to consider simultaneously when planning harvest times for individual blocks on farms including variety, crop class, crop age, CCS, cane yield, soil type and micro-climates. Each blocks location within the farm also comes into the time of harvest decision due to factors such as flood risk and attractiveness to pests.

Regional management differences such as varieties, irrigation, group rotations and mill throughput means that harvest planning processes also vary across regions, therefore an industry-wide method is not appropriate.

Therefore, the sugar industry has developed harvest planning tools to better manage: variety selection, crop age and crop class management, harvester migration and trafficability in wet weather, risk management of harvest, and to plan for better accommodation of climate forecasting indicators.

However, these systems have not been adopted by the industry as the most profitable option for the industry is also the one with the least equity at the farm and harvester group level.

Mallee System

Mallees are grown as permanent crops. It is expected that mallees will be harvested repeatedly on about three to seven year rotations, with the length of rotation determined by the harvest yield. The season of harvest combined with the soil profile (availability of soil moisture) will need to be managed so that mallees liable to be under severe moisture stress on shallow soils are only harvested in optimal conditions of spring and early summer. This is discussed in greater detail in section 1.4.3 and 1.4.4.

2.5.2 Harvest monitoring

Sugar System

Knowing how much cane remains to be harvested during a crushing season has always been an important task undertaken by mill field staff. The pre-season crop estimates form the basis of many facets of raw sugar manufacturing from marketing and logistics, planning mill start dates, cane transport arrangements, harvest groups base daily loadings and harvesting schedules. Changes in farm estimates during the season often occur and will therefore affect many of those facets identified above.

Traditionally, mills used a proportional re-estimating program to determine the amount of change in farm estimates. In its simplest form, this is the calculation of a ratio comparing the actual yield for an area of harvested cane against the original estimate for that same area and applying the calculated ratio to the remaining crop estimates for each farm.

The sugar industry has been using GPS as a management tool to keep records of the location of various vehicles for a number of years. The first commercial GPS vehicle tracking system developed in Australia was the GEOSTAT locomotive tracking system developed by Tully Sugar Limited and GS Corporation in 1993 (Fuelling and Wright 1997).

Developments in harvest management systems have seen the mounting of GPS on harvesters to monitor where harvesters have worked. Various harvester monitoring systems are currently in use with the main components comprising data logger, GPS and modem.

Mackay Sugar developed a harvester monitoring system during the 2005 and 2006 seasons. MTDData tracking and data logging units form the basis for the harvester performance and tracking system. A GPS tracking device records the position of the harvester and stores it in a data logger awaiting transfer to a central web site. The MTDData units include elevator on/off and engine on/off digital inputs to allow the status of the machine to be determined.

Crossley and Dines (2004) undertook trials to integrate harvester tracking with a mill-based spatial harvest recording system during the 2002 and 2003 seasons in the NSW mills. The hardware was a dedicated system assembled by Transcom, and consisted of a data logger, GPS and a CDMA modem. The data recorded by these units consisted of a series of positions of the harvester, and machine status at those times.

Harvesters monitoring data was stored on the harvester for the day and uploaded to a central server each night. A customised GIS software application called CHOMP (Centralised Harvest Operations Management Program) was used to interpret the areas cut and maintain the paddock harvest status from a map interface (Beattie and Crossley 2006). Figure 2.10 illustrates GPS harvester tracking in a NSW harvested field.



Figure 2.10 GPS harvester tracks in a harvested field, coloured by speed (Beattie and Crossley 2006)

An integrated harvester performance and monitoring management system offers the sugar industry significant improvements over existing harvest and transport operations. Technologies have already been implemented in a number of mill areas such as Mackay Sugar and NSW Sugar Milling Co-operative to enhance operations and add value to harvest and transport management.

Mallee System

A future mallee system will require all available technological capacity to achieve the essential levels of efficiency required with a dispersed low value resource. The experience of sugar will play an

important role in this, with the principal area of concern being the logistics in the field over short time periods.

While the critical cut to crush factor of sugar cane will not exist and while it is possible to add storage into the transport at a marginal capital cost through more bins, management of road transport must be fully integrated into the harvest system. Ideally infield haulouts, filled directly from the harvester, take either bins or trailers to the nearest trafficable road and leave them there, pick up an empty container and return to the field. Road transport would take these bins to the factory and return them in a timely fashion. Given the dispersed layout of mallee paddocks where haulout distances will vary from metres to kilometres it is anticipated that a shunt truck arrangement will be required to transfer bins from the paddock landing or field edge to a road transport landing. .

Coordinating the harvester, its accompanying haulouts and the associated shunt truck will be the most important area for an integrated performance and monitoring system, with the objective being to maintain high levels of harvester and haulout utilisation.

After the shunt transport operation from the paddock landing to the road transport landing, timing will be less critical. The ex-harvester biomass is relatively stable in stockpiles for periods of a few days, and the critical cut-to-crush factor of sugar cane will not exist. There must also be a substantial stockpile of weeks duration at some point between the road transport and the market(s) for the biomass. Therefore rather than having to place an equal emphasis upon harvest, haulout and road/rail transport as in sugar, in mallee the long-haul road transport operation will be relatively easy to manage and most of the focus will be on the infield operations.

2.5.3 Capacity Planning

Sugar System

Sugar industry schedules are difficult to arrange as there are many interdependent factors to consider. Separate ownership within the industry's harvesting and cane transport, growing and milling has also meant poor integration and inefficient practices at these interfaces. A change in one part of the system will affect other parts of the sugar supply chain causing many logistical challenges.

However, several mill regions within the Australian sugar industry are exploring opportunities to reduce costs within their harvesting and transport system. Typical issues include reducing the number harvesting groups, harvesting over a longer time window in a day, rationalising/upgrading transport infrastructure, implementing harvest best practice, removing some of the inefficient practices in cane transport such as the double handling of rail bins and achieving a better co-ordination between harvesting and transport activities. Within the cane harvesting and transport sectors, many existing inefficiencies are a result of excessive numbers of harvesting machines owned by harvester contractors and growers, and the fact that most harvesters operate within a short time window each day.

Prestwidge et al. (2006) investigated the opportunities for adding cane loading pads for road transport to reduce haulout distance and consequently the costs of harvesting across three mills regions in NSW. They adapted two existing modelling tools to the NSW sugar region, namely the Siding Optimisation Model (Higgins and Laredo 2006) and the Harvest Haul Model (Sandell and Prestwidge 2004). The Siding Optimisation Model, originally used for locating sidings on a cane railway system, was adapted to the road transport system in NSW and was named the Pad Optimisation Model. They suggested harvesting cost savings of \$786 000 over 5 years (across the three mills) could be realised from investing in additional loading pads at optimal locations. The outcome of this study was the expansion of existing pads and the construction of new pads to reduce haul distance. This is an essential component of the whole-of-crop harvesting system adopted by NSW Sugar Milling Co-op (NSWSMC). Further discussion on supply chain management tools and capacity planning is given in Chapter 6 of the report.

Mallee System

A high level of coordination between harvesters, infield haulouts, shunt trucks (where required) and road trucks will be required for an efficient harvest and transport system. The logistics will depend on the harvester delivery capacity and harvester delivery capacity will be defined by the logistics.

The location of loading points to provide optimal haul distances will require careful consideration. The paddock landings (pads in sugar cane) will be used for periods of a few hours every few years to handle modest tonnages of biomass, which precludes the cost of significant site preparation. Therefore vehicles using these points will need to be paddock-capable. Road transport landings will be used for larger tonnages and better site preparation will be required to accommodate all weather access for road train trucks. It is hoped that the flexibility introduced by the use of a shunt transport stage will permit these road transport landings to be located opportunistically, such as at disused railway sidings, where costs of access and site preparation can be minimised.

The structure of harvester “groups” can be optimised in mallee with appropriate coordinated industry development. If the number of harvesters and the composition of each harvesting unit is optimised from the outset, the new industry can avoid many of the inefficiencies that have evolved in sugar, such as the large number of harvesters supplying each mill, with some harvesters operating for short periods each day. Industry development planning, informed by the wide range of experience in the sugar industry, will be one of the significant results of this project.

2.5.4 Harvest to process delays

Sugar System

Sugarcane is a perishable commodity and must be processed into sugar quickly after it is harvested otherwise its commercial value deteriorates.

Most of the sugar mills operate under continuous crushing arrangements, 24 hours a day, seven days a week, during the crushing season. Continuous crushing proves a better utilisation of transport and milling capital.

Cane deteriorates after burning or harvesting. Rapid deterioration of cane is caused by a bacterium that enters the cane pieces at the instant of cutting and produces a sugar polymer, dextran. Dextran is formed by the action of bacteria on sucrose.

The deterioration of chopped cane is accompanied by a rapid increase in dextran. When processed, deteriorated cane causes process liquids to increase in viscosity, with a decrease in factory capacity. Increases in dextran in chopped cane are accompanied by slower clarification and mud filtration. Sugar losses in processing due to dextran are indicated by the correlation of the dextran content of process liquids and final molasses purity. Inhibition of crystallisation of sucrose by dextran results in the formation of needle ‘long post’ (sucrose crystals elongated on the C axis) crystal rather than the more desirable “cube” shaped crystals.

This reduces the efficiency with which sucrose may be extracted in the mill and in the refinery. Removal of dextran in the mill is possible but is costly and hard to implement.

Deterioration is more rapid in chopped cane than wholestalk with quality losses evident in 24 hours, or even 14 hours. In burnt cane dextran begins to form in half the time taken in green cane, and the increase is more rapid. Dextran is reduced by minimising cut-to-crush and burn-to-crush delays.

Short and/or damaged billets, poor crop presentation and pests and diseases all increase dextran. Dextran formation is more rapid in hot and/or humid conditions.

Hence, Australian sugar mills organise their transport scheduling to ensure that most harvested cane is crushed within 12-16 hours of harvesting, with only a small proportion crushed 16-24 hours after harvesting. All cane is crushed within 24 hours of harvesting unless there is a temporary transport problem (Dawson, 2004).

Mallee System

The mixed material in chipped form is liable to decompose significantly over a period of a week. It is preferable to sort the leaf and residues from the wood chip if wood chip is to be stored for any period (Giles and Harris, 2003).

The need for and role of material stockpiles will need to be evaluated in terms of the supply chain management and impact on product quality. Stockpiles are a risk management strategy and can ensure continuous feedstock supply in case of interruptions (e.g. inclement weather, fire, flood, soft soils, or mechanical breakdown).

Spoilage may be significant for wood chip/leaf mixtures within a week and spontaneous combustion may be the main factor for large stockpiles. Before combustion happens, the fungal activity will make the product an OHS issue and bind the material into a mass making future handling difficult.

Eucalyptus wood chip is relatively stable and commonly stored in open stacks for periods of several weeks without significant loss of quality (e.g. wood chip export and paper mills). Chip is generally the highest value product.

A chip cleaning stage to separate foliage/leaf and clean chip could be considered as part of the process. This would allow stable storage of the chip, whilst the foliage and fine material can be processed as quickly as possible.

The quantity of material to be stored in the stockpile is still to be determined. However the ability to stockpile ex-harvester biomass for a few days, and sorted and dried biomass for longer periods, will introduce significant flexibility into future mallee operations.

2.5.5 Discussion

An integrated harvesting management system will need to be developed to provide efficient harvest and transport operations. In particular the location of loading points to provide optimal haul distances will require careful consideration. Generally, woodchip is the highest value product and strategies for separation of wood chip from the other biomass components will be considered. Drawing on the experience of the sugar industry will be fundamental to the development an efficient harvesting and transport system in mallee.

2.6 Harvesting Costs and Payment Structures

2.6.1 Payment Structures

Optimal harvest structures and policies that increase whole-of industry profitability through the establishment of meaningful pricing structures that reflect quality of work and output, and that improve efficiency and market satisfaction are a key element of any industry.

Sugar System

The current harvester payment system, where harvest operators are paid at an agreed rate for each tonne of delivered cane product (i.e. including extraneous matter and soil) that they harvest, has been in place for many years. While it is easy to monitor and understand, dollars per tonne sends a very clear market signal to the harvester that tonnes per hour equals profit per hour and quality is a minor

focus. It raises a fundamental question regarding the market signals that are sent to each participant in the cane supply chain (i.e. farmers, harvesters and millers).

This dollars per delivered tonne system encourages harvester operators to cut at high pour rates because they receive greater income by cutting the maximum possible tonnage per hour, at the same costs per hour, thus making more profit. However, harvesting at high pour rates, increases the levels of extraneous matter (EM) and soil in cane, and these in turn decrease CCS and increase mill costs. High harvester fan speeds are used in an attempt to control EM levels, but with marginal success and, importantly, with high cane losses.

While this dollars per tonne payment system encourages maximum efficiency in terms of maintaining a high delivery rate, it ignores the cost of cane loss because the cost of lost cane to the harvesting contractor, who receives a smaller fraction of the total value, is insignificant compared to the increased money made from high machine throughput. Thus, the behaviour that is encouraged by the current payment system is the antithesis of harvesting best practice, which is based on the premise that low fan speeds and low pour rates produce cane in the bin of better quality with minimal cane loss.

Per tonne payment systems also do not encourage improvements in farm layout (especially since growers are more likely to change operator for pricing reasons rather than job-quality issues), another factor that is closely involved in the overall efficiency of harvesting. Harvesting costs are very sensitive to farm layout factors such as row length and haul distance.

The Boston Consulting Group (2004), lists a set of key criteria for the design of an ideal payment system, as follows:

- Integration of the growing and processing requirements that reward cooperation.
- Accurate market signals reliably reflecting the quality of cane supplied.
- Effective utilisation of capital at all steps.
- Production of a range of products of different values.
- Practical, robust and simple financial drivers suitable for long term use.
- Consistent price messages all going in the same direction.
- Changes in price that benefit all parties by a similar amount, with sharing of market risk enhancing cooperation.
- Ensuring that no party has excess power over the others.
- Minimising of adversarial relations between parties.
- Ensuring that season length has a minimal impact on all stakeholders.
- Maximising the economic return to the whole industry through optimum yield of sugar and other products sold.

The best way for the whole supply chain to maximise its net revenues from the three inter-linked business groups is to create strong direct commercial links between the three, using whole-of-chain incentives based on available sugar in the field and the payment for sugar and other products at the market. If these net incentives were in place, operational decisions made by farmers, harvesters and millers would be likely to be focused on a common goal of maximising returns. This goal should become part of an agreed harvest plan that maximises net incentives and therefore maximises net revenues across the whole supply chain. The allocation of shared returns must be equitable to millers, farmers and harvesters and reflect the costs incurred and risks taken by each party in contributing to the whole-of-chain result.

An analysis of alternative harvest payment systems is summarised in Table 2.11. It should be noted that several of the options do not offer sufficient commercial incentives to the parties to improve sugar recovery but focus instead on mechanisms to allocate current revenue rather than on first increasing the amount of revenue available across the supply chain.

Table 2.11 Alternative harvest payment systems options, consequences and incentives (SRDC, 2004 and Jones, 2004)

Payment System	Advantages and Disadvantages (advantages in bold) HBP = Harvest Best Practice	Consequences	Feasibility and Attractiveness
1. Dollars per tonne of cane (Current System)	<ul style="list-style-type: none"> • Widely known system • Easy to administer as relates to tonnage along supply chain —Not open to abuse • Inbuilt HBP disincentive-rewards high speed harvesting • Heavy cross subsidisation of poor productivity • No incentive for extra work or harvest quality • Does not encourage improvements in farm layout • Discounts the importance of the key parameter viz capturing the total tonnage of available sugar 	<ul style="list-style-type: none"> • Harvester will not perform a quality harvest as there are no incentives • Farmer will lose sugar in the field and may suffer stool/field damage • Miller will receive higher EM and incur higher costs 	<ul style="list-style-type: none"> • Currently feasible but results in significant losses along supply chain. Does not create net incentives to maximise economic sugar • Limited attractiveness
2. Dollars per hour	<ul style="list-style-type: none"> • Enables full HBP economic incentives to capture “economically viable” sugar to flow to harvester and grower • Allows automatic accounting for variable yield • Enables full economic incentives to flow to growers from better farm design • Encourages improved crop presentation • Promotes closer pre-harvest planning between harvester & grower • Penalises growers distant from receival pads/ sidings, especially in wet weather • Requires detailed accurate time recording by machine operators and authorisation by farmers • Opportunity for human error in recording of time • Opportunity for unscrupulous charging of time by harvest operators 	<ul style="list-style-type: none"> • Harvester has power to agree specific commercial incentives with farmer and miller • Farmer faces greater risk of poor admin and time keeping, but will capture added revenues if arrangements are on clear contractual terms • Miller will receive increased volume of clean cane with positive impact on net revenue. 	<ul style="list-style-type: none"> • Currently feasible and commercially attractive • Requires enhanced pre-harvest planning and contractual arrangements between the parties to agree how time will be managed and risks and returns allocated
3. Base Price + Fuel (\$/t fuel supplied by grower)	<ul style="list-style-type: none"> • Easy to manage for both fuel and tonnage • Partially accounts for farm layout variations • Introduces flexible fuel pricing options • Enables partial economic incentives to flow • Some cross subsidisation of poor productivity • Partial disincentive for extra work or harvest quality • Limited incentive for improvements in farm layout 	<ul style="list-style-type: none"> • Harvester will focus on cost management rather than quality. • Farmer assumes more cost risk without guarantee that harvester will capture maximum sugar. • The Miller’s cane supply and quality will not be improved 	<ul style="list-style-type: none"> • Currently feasible • Focus will be on cost competitiveness; not incentives to maximise sugar • Limited attractiveness
4. Quoted Price Using BSES Model	<ul style="list-style-type: none"> • Provides verifiable economic quotations • Significant effort required to understand & use the model the first time • Needs annual review, possibly between harvest rounds to recognise changes in yield estimates 	<ul style="list-style-type: none"> • Uncertain, subject to components of model 	<ul style="list-style-type: none"> • Uncertain, subject to components of model
5. Dollars per hectare	<ul style="list-style-type: none"> • Easy to administer based on agreed field areas • Makes harvester budgeting easier — revenues are known • Farmer’s costs are known • Inbuilt disincentive-rewards high speed 	<ul style="list-style-type: none"> • Harvester will focus on cost management • Farmer will lose sugar in the field • Miller’s cane supply and quality will not be 	<ul style="list-style-type: none"> • Currently feasible • Focus will be on cost competitiveness; not incentives to maximise sugar

Payment System	Advantages and Disadvantages (advantages in bold) HBP = Harvest Best Practice	Consequences	Feasibility and Attractiveness
	<ul style="list-style-type: none"> harvesting • Enables cross subsidisation of poor productivity • Limited incentive for extra work or harvest quality • Limited incentive to improve farm layout 	improved	<ul style="list-style-type: none"> • Limited attractiveness
6. Floor price	<ul style="list-style-type: none"> • Enables some flexibility as rate reverts to an hourly base if tonnage /ha is low • Uses the BSES Rate Calculator Model as a starting point • A bet each way — implications are likely to be too complex and risky for farmers and harvesters • Requires prompt and accurate tonnage and area feedback and monitoring to work effectively 	<ul style="list-style-type: none"> • Harvester will focus on cost management • Farmer will lose sugar in the field • Miller's cane supply and quality will not be enhanced 	<ul style="list-style-type: none"> • Currently feasible • Focus will be on cost competitiveness; not incentives to maximise sugar • Limited attractiveness
7. Dollars per tonne of sugar	<ul style="list-style-type: none"> • Directly links maximum whole chain revenue to harvester incentives for harvest quality • Difficult to manage as sugar varies across mill area. Geographic harvest options required. • Farmers fear loss of harvest equity from geographic harvesting • Technology constraints — difficult to accurately measure and monitor sugar at the harvester • Complicated by delay in delivery to the mill and loss of quality — 24 hour transport scheduling 	<ul style="list-style-type: none"> • Would deliver optimum net incentives to all parties but only where payment system was reset to better allocate benefits 	<ul style="list-style-type: none"> • Feasible, subject to payment system realignment • Most attractive option
8. Pay Direct Economic Incentive for Adoption of HBP (\$0.5/t +share of net revenue gains)	<ul style="list-style-type: none"> • Establishes a clear pre-agreed attractive economic reward for harvest performance based on specified field practices and maximum sugar recovery • Amenable to current cane payment arrangements • Allows flexibility to parties to agree locally in mill area • Needs to be negotiated by parties on a mill area basis — including sharing of net gains to farmers, and millers • Does not fix all the inadequacies of the current payment system 	<ul style="list-style-type: none"> • Will result in immediate positive change in practice, quality of harvest, and economic flow on to growers and millers • May result in additional harvest tonnage and extension of season length 	<ul style="list-style-type: none"> • Currently feasible and commercially attractive • Focus will shift from cane pricing to revenue maximizing.

The most common alternative payments systems in use throughout the industry as identified by Willcox et al. (2005) are listed below. One of the key findings of this work was that it only requires a weak economic price signal to facilitate change.

Base Rate plus Fuel (BR+F). This method is widely used at Mackay, Burdekin and Maryborough. There, the base rate varies between \$5.50 and \$5.80 per tonne depending whether burnt or green. The fuel is paid for by the grower but delivered to the contractor's tank. The system is easy to monitor and 'police', because it is a simple system. It is fair, because the grower pays for fuel actually used on their farm. It does reduce the level of cross subsidisation, but still puts the cost of bad blocks back onto the harvester. BR+F still sends the market signal for high pour rates to maintain viability, but not as much as \$/tonne.

b) Base Rate plus Fuel at higher rate. This method uses a base rate but the fuel is priced higher (e.g. \$2/L) to allow for labour. The system is used by some groups in New South Wales. The amount of fuel used is measured and the grower invoiced at set price. The reasoning behind this system is that paying for fuel alone does not compensate for machinery and labour costs.

c) Hourly Rate. This method pays on engine hours similar to the hire of most earthmoving equipment and is negotiated between grower and contractor. Rates used for pilot group examples were \$350-420/hour, depending on the number and size of haulouts. For acceptance, monitoring equipment is needed for growers to know that the machine was working as contracted, e.g. fan speed, forward speed, GPS tracking. Hourly Rate sends the best market signals, as it creates the greatest variation in price per tonne and reflects true cost, as most variable costs are accumulated on an hourly basis. This encourages best-practice farming, as the more efficient a farm is to harvest and the better the crop size and yield, the lower the cost per tonne to harvest. By providing a stable income to the operator, it allows the grower to prescribe the mode of harvester operation for each block. If a grower does not understand the financial benefits of HBP, this could lead to unwise decision-making focused on minimum time and, hence, minimum cost at the expense of high cane loss, low cane quality and poor ratoons. To operate efficiently, hourly rate needs to be linked to a cane quality measurement system at the mill to provide targets for cane quality. In addition, there is no incentive for the harvester to reduce cane loss, so settings of the harvester, such as extractor fan speed and forward speed, need to be monitored.

d) Sliding-Scale Base Rate plus Fuel. This method uses a sliding scale based on crop yield to calculate a base rate, e.g. \$6.30 for 35-45 tonne/ha to \$5.70 for 95-105 tonne/ha. Fuel is purchased by the grower. This appears a simple system with good market signals. It is transparent and easy to apply. The base rate covers cane loss issues and true fuel costs are covered. The sliding scale covers some of the labour and machinery costs associated with crop size. It reflects true cost a little better, but is still a tonnage rate, which encourages maximising pour rate and delivery rate.

Mallee System

The harvesting payment structure is yet to be determined. An important influence upon this will be the business structure(s) that is set up by the new industry, and where the point of sale occurs along the supply chain. One commonly assumed model is that farmers merely grow the mallees and all supply chain operations and costs are managed by the biomass purchaser's agent, but this is likely to see very low returns to the farmers and limited adoption of mallee as a crop. The current mallee resource is not adequate to support a significant processor industry, so expansion of the resource is a precondition of the existence of a substantial industry. Farmers are yet to be engaged by the prospect of a new industry at the scale required for large industrial conversion processes to be established, and they need tangible commercial incentives to participate.

There would be advantages to vertically integrating the supply chain and for the point of sale to be as far along the supply chain as possible to minimise the problems of the farmer-harvester-mill conflicts of interest observed in the sugar industry.

2.6.2 Cost of Harvesting

The typical price of harvesting cane in the cane industry varies. The price varies depending on the payment structure (e.g. flat rate, base rate + fuel), the harvesting contract structure (e.g. Co-operative, contractor, miller) and the crop condition (e.g. burnt, green).

Harvesting costs may be apportioned in various ways, per tonne of cane, per hectare, or per hour. Traditionally, costs are quoted in dollars per tonne of cane harvested. However, in reality, harvesting costs are largely incurred by the hour:

- Machinery depreciates by the hour
- Harvesters and haul tractors have a useful life of 10 000 hours

- Wages are an hourly rate (or equivalent value)
- Fuel is consumed at a fixed hourly rate
- Repairs and maintenance costs are incurred by the hour.

The typical price for various mill regions is shown in Table 2.12 and is inclusive of harvester and haulouts. However, throughout the industry there are allowances such as overtime (\$0.93/tonne) and haulage (cost dependent on distance from siding) up to \$0.40/tonne which are paid by the mill to the harvesting contractors or direct to the grower depending on harvesting payment arrangements.

Table 2.12 Cost of sugarcane harvesting

Crop Condition	NSW		Bundaberg	Ingham	Burdekin
	Flat Rate	Base Rate + Fuel	Flat Rate	Flat Rate	Flat Rate
	\$/t	\$/t	\$/t	\$/t	\$/t
	Co-operative	Co-operative	Contractor		Contractor
Burnt	5.50		5.80	-	7.10-7.40
Green	5.80-6.00**	4.00 + 1.00/L	6.80	6.80	-

*Co-operative structure and 2-yr-old cane

**Co-operative structure

The cost of harvesting (charged to the grower) has not increased much over the past 10 years. Data from SRDC (2004) shows that in 2002/2003 the cost of harvesting was about \$6.80/tonne as shown in Table 2.13. Current costs are in the order of \$10 per tonne, slightly less for NSW.

Table 2.13 Typical costs of sugarcane harvesting (SRDC, 2004)

Cost	\$/t Green Cane
Depreciation	1.24
Wages	1.51
Fuel and oil	0.72
Repairs and maintenance	2.10
Capital ownership	0.76
Overheads	0.45
Total	6.78

Harvesting contractors can influence the size of the group. However, there is a substantial argument to show that the harvesting contractor has less control of group size than might be thought. The

contractor does not have formal, written agreements and may lose substantial portions of the contract at any time. Grower decisions to accept, reject or change a contractor are often made on perceptions or traditional relationships, rather than on performance criteria. Competition between groups leads to under-cutting of harvesting price. Available cane may be geographically isolated from the remainder of the group, making it less economical to accept.

The effect of the size of the harvesting group on the cost of harvesting is shown in Figure 2.11.

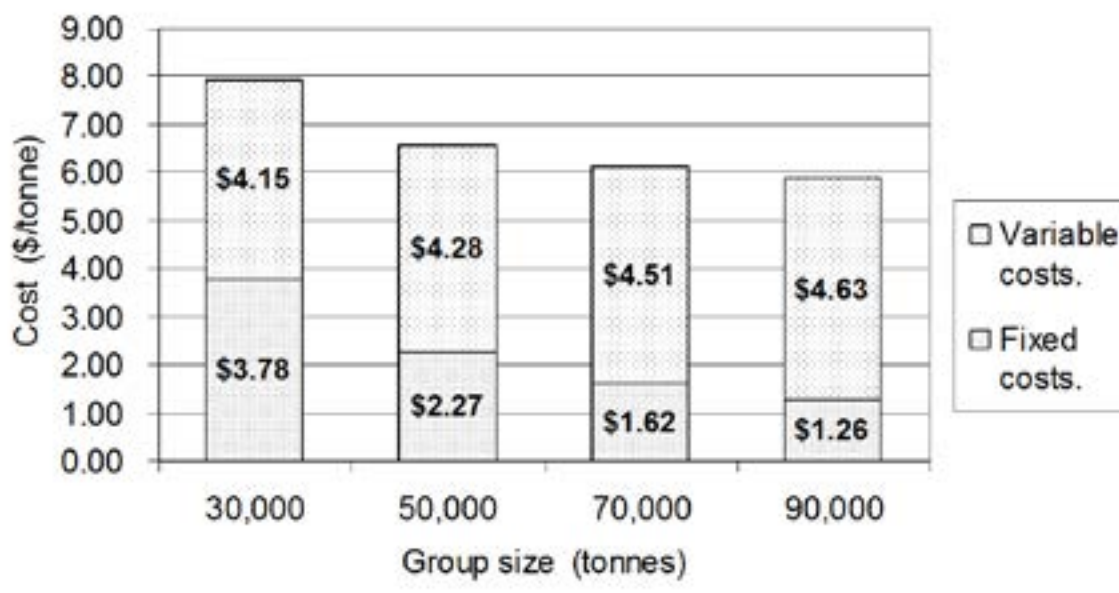

Figure 2.11 Effect of group size on harvesting costs (Sandell and Agnew, 2002)

The harvesting contractor has no influence on crop yield, although this has a significant impact on the cost of harvesting as shown in Figure 2.12.

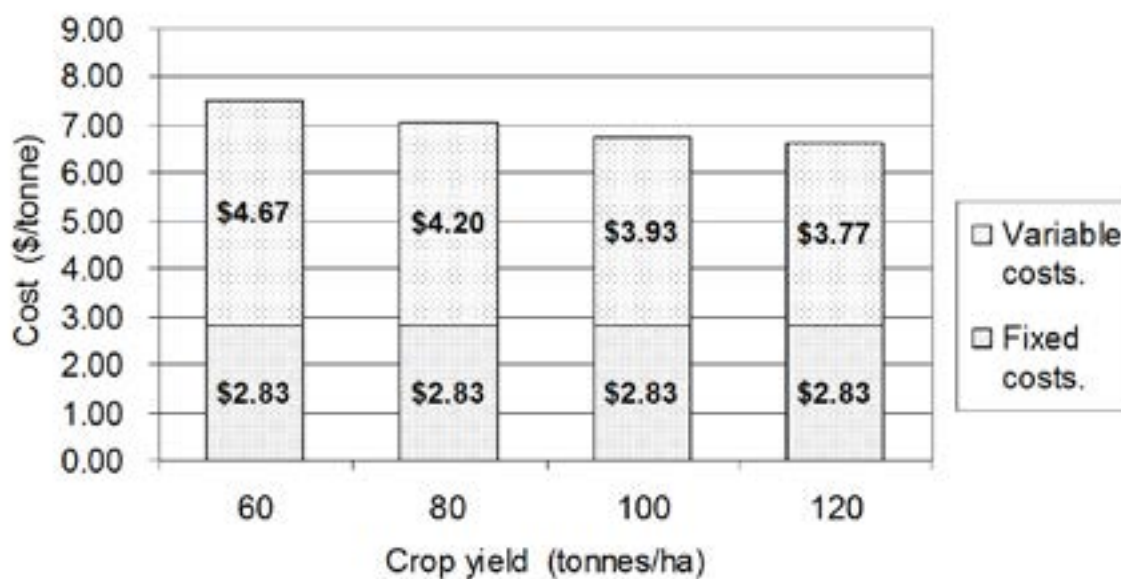

Figure 2.12 Effect of crop yield on harvesting costs (Sandell and Agnew, 2002)

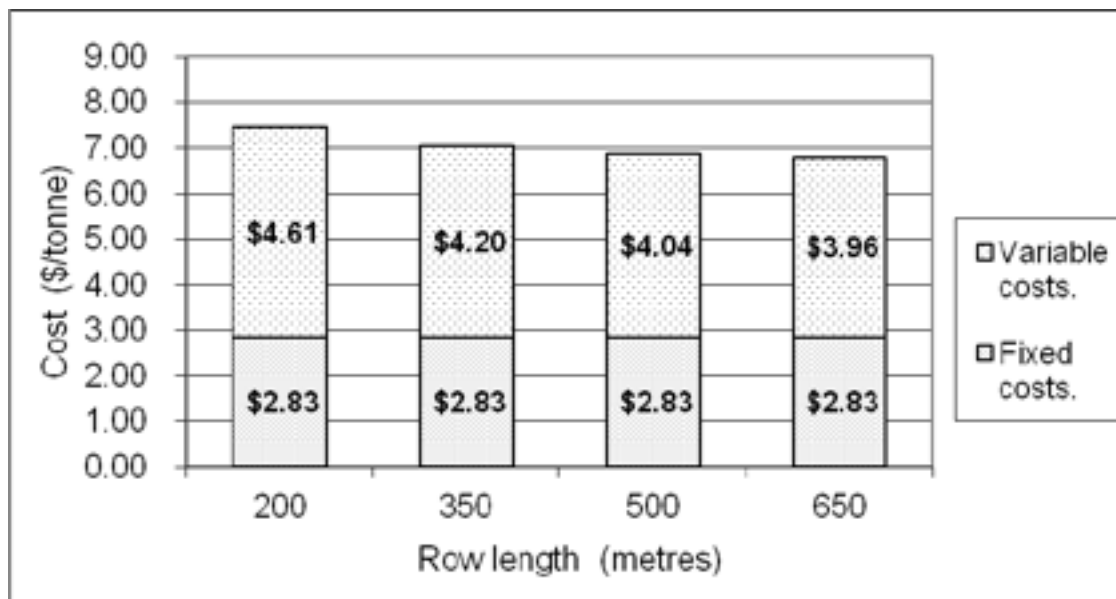

Figure 2.13 Effect of row length on cost of harvesting

Mallee system

Chapter 7 presents the results of modelling a hypothetical mallee supply chain using the Harvest Haul Model (Sandell and Prestwidge 2004) adapted to mallee for this project. Three scenarios were modelled, reflecting various levels of capital investment and technological sophistication.

As mallee has not been harvested commercially in the way described in this report (that is a over-the-row harvester supply chain analogous to cane systems), the results of this modelling are not accurate in the absolute sense, but they do provide valuable insights into the sensitivity of costs to various factors, and it is also possible to make an important comparison with sugar industry costs.

Figure 2.14 and Table 2.14 describe the influence of annual tonnage per harvester (comparable to the cane industry group size) and harvester pour rate upon cost per tonne for biomass delivered to the field edge (that is, to the paddock landings).

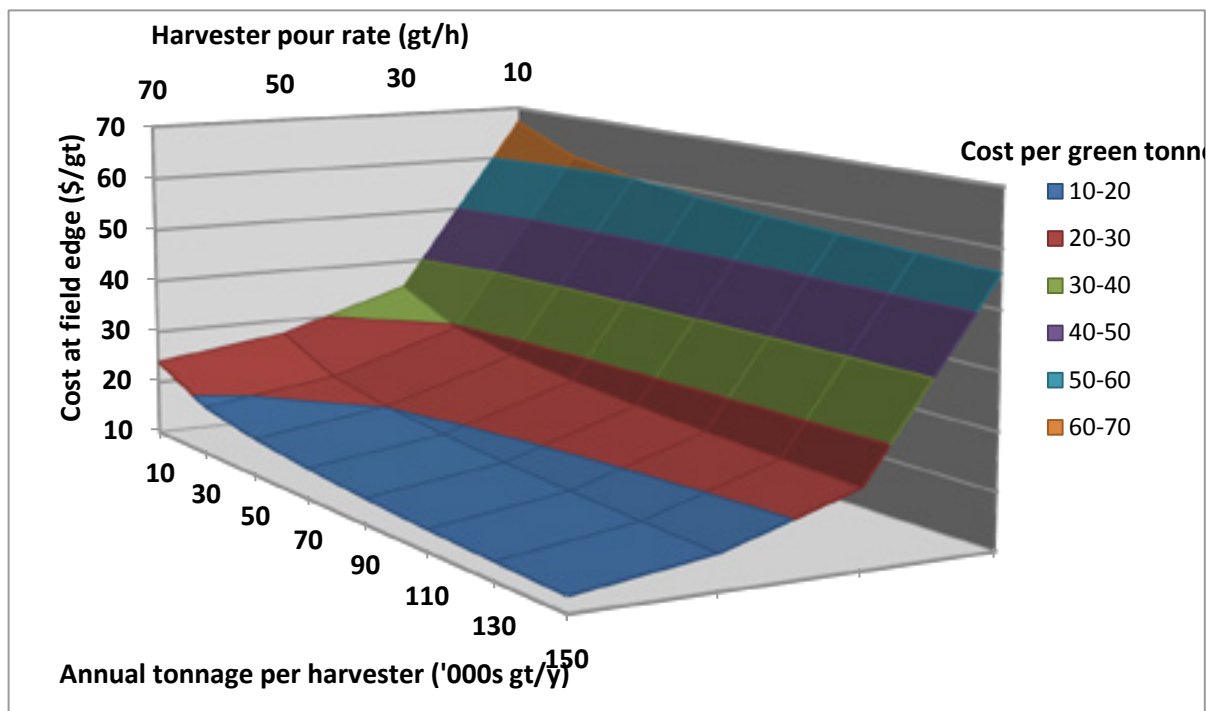

Figure 2.14 The effect of harvester pour rate and annual tonnage per harvester upon cost of biomass harvested and delivered to field edge

Table 2.14 Estimated costs of mallee harvesting, excluding profit and tax

Estimated cost per green tonne ¹			
Annual tonnage per harvester (green tonnes)	Pour rate		
	30	50	70
30,000	30	22	19
50,000	28	20	17
70,000	26	19	15
110,000	25	17	14
150,000	24	16	13

¹ These estimates were based upon a total capex of \$2.5 million for a harvester, two haulouts, and enough bins to handle the daily biomass production. The resource density was low, assumed to be two row belts at 225 metre spacings. No shunt truck costs have been included, and if logistics demand this additional transport step, another \$3 (at >70,000 gt/y) to \$4 (for low annual tonnages) per green tonne would apply to these costs. Road transport costs are in addition to these costs,

Low annual tonnages and low pour rates cause costs to rise significantly, and when the industry is mature and harvesters work two shifts a day at higher pour rates, costs may fall as low as \$13 per green tonne at the paddock landing. Estimates of a shunt truck as the intermediate form of transport have not been modelled as part of this project but indications are that this operation would add \$3 to \$4 per green tonne for biomass loaded onto road transport trailers at a roadside landing about ten kilometres from the harvester.

Proven systems robust enough to harvest mallee at full scale have not yet been demonstrated commercially, hence the actual cost of harvesting is unknown. However, the theoretical costs are still well above that of sugarcane harvesting per tonne.

The importance of harvest/transport costs on overall supply chain economics should not be underestimated.

2.6.3 Discussion

At equivalent pour rates, the cost of sugarcane harvesting is less than half that of the estimated cost of mallee harvesting. Actual costs of mallee harvesting are unknown. While yields per km of row are similar to that of sugarcane, a mallee harvester's speed while cutting will be about half that of cane harvester. The installed power of a commercial mallee harvester will also need to be perhaps twice that required for cane harvesting due to the energy intensive nature of wood chipping, and mallees are a much more dispersed crop on a whole paddock hectare basis, which will add to infield transport costs.

2.7 System Improvements

Sugar System

Over the past 30 years, the research and development activities within the harvesting arena of the Australian sugar industry can be grouped into three distinct periods.

During the 1980's, research and development was centred on performance evaluation of machines in green cane harvesting with Ridge and Dick (1988), Stewart and McComiskie (1988) and Shaw and Brotherton (1992) investigating throughput, EM and cane losses during cleaning. Ridge and Dick (1988) also investigated dirt rejection by harvesters.

During the 1990's, research commenced on the fundamental interactions between the crop and machine components with Pearce (1994), Kroes and Harris (1994), Kroes and Harris (1995), Kroes (1997), Schembri and Garson (1996), Norris et al. (1998), Norris et al. (2000), Hockings et al. (2000) and Zillman and Harris (2001) investigating gathering, knockdown, feeding, basecutting, billeting and primary cleaning systems. Research into improving feeding ability and performance in large green crops continued into the 2000's with Davis and Norris (2002a), Davis and Norris (2002b), Davis and Norris (2003), Davis and Schembri (2004) and Whiteing and Kingston (2008).

Throughout this period ongoing cane quality (EM/Dirt) issues and cane losses were evaluated by Linedale and Ridge (1996), Fuelling (1999) and Schembri et al. (2000). Whiteing et al. (2001, 2002) undertook fundamental investigations into the effect of fan speed and pour rate on cane loss and EM.

In recent times the industry has been striving to improve the efficiency and productivity of its sugarcane harvesting and transport practices. Over the past few years the research focus has been on harvest system modelling (e.g. Higgins and Langham (2001), Antony et al. (2003), Higgins and Davies (2004), Sandell and Prestwidge (2004)), harvesting best practice (e.g. Sandell and Agnew (2002), Willcox et al. (2004), Muscat and Agnew (2004)), sugar losses (e.g. Davis and Norris (2001), Sichter et al. (2005)), harvest and transport integration (e.g. Crossley and Dines (2004), Markley et al. (2006)) and harvester automation (e.g. Esquivell et al. (2007)).

The most significant program aimed at increasing sugar industry profitability has been through a whole of system approach to harvesting. Whiteing et al. (2001, 2002) and Agnew (2002) developed what is known throughout the industry as Harvesting Best Practice (HBP). The ultimate aim of HBP is to maximise profit to all parties, contribute to the sustainability of the sugar industry and to improve sugar quality. HBP is a set of guidelines which examine harvester set-up and operational settings, field conditions, farm layout, farm practice and their effect on harvester performance, cane quality, sugar quality and industry profitability.

The key machine set-up and operational guidelines are focused on cane loss, cane cleaning and finding a balance between these two issues.

HBP recommendations have been presented to the industry for a number of years and the economic benefits have been well documented and rigorously defended. However, despite the significant economic benefits, adoption of HBP has been slow. This has been due to industry skepticism about sugar loss levels and pressure to minimise extraneous matter and transport costs. The invisible nature of the sugar loss makes it difficult to convince some industry stakeholders of the importance of HBP.

In addition, it is also hard to encourage the adoption of HBP especially when it has long been recognised that the current one-price, dollar-per-tonne payment method for harvesting does not have built-in incentives to adopt best practice or supply quality cane. Better feedback is vital to overcome the flawed harvester-payment system and enable negotiation of the best possible job at an acceptable price for individual blocks.

As the primary revenue received is for sugar sold, the primary focus for HBP is maximising the size of the revenue 'cake' and only then can more appropriate and more equitable ways of 'dividing up the cake' be developed.

In the past, many component-research activities were aimed at increasing harvesting efficiency in the Australian sugar industry. Many of these have been engineering approaches to improved harvester design, including improved basecutters: (Schembri, 2000; Schembri et al. 2000; da Mello and Harris, 2001) and overall harvester design (Norris et al. 1998). Other approaches were targeted towards best practice, for example the impacts of fan speed and pour rates (Agnew and Sandell 2002). Alternative pricing schemes for harvesting have been studied (Chapman and Grevis-James, 1998) to better quantify harvesting cost for the grower and to encourage incentives to lower the cost of harvesting. While these approaches can add value to the harvesting sector, the improvements are not sufficiently evaluated across the supply chain to consider the overall net benefits.

Mallee System

Initial studies on the mallee industry concluded that a harvesting methodology remains the largest gap in the industry supply and processing chain. Hence, research and development has concentrated on developing a harvesting system based on a chipper harvester.

Whilst most studies have focused on a systems perspective, the lack of a proven harvesting system robust enough to harvest mallee commercially has constrained the availability of quantitative data.

The key to system improvement will be to know what product is the supply chain objective, and develop a better understanding of the likely impacts of crop and machine performance factors on overall system economics based on quantitative data. At this early stage it is possible to consider where the biomass supply chain should terminate; at the field edge, or as energy output from a biomass-fuelled boiler, or somewhere in between.

The lack of data is a serious constraint on mallee industry planning, but there is the opportunity to learn from the sugar industry experience, to increase the amount of revenue generated from the overall supply chain, and to distribute that revenue appropriately across the supply chain. The most appropriate supply chain structure and careful management of incentives and rewards will enable the most rapid systems improvements in the future.

2.8 Discussion

Sugarcane harvesting and transport has many similarities with mallee harvesting. Whole-of-crop sugarcane harvesting with all material (cane and trash) transported to the sugar mill is the system with the closest synergies with the mallee harvesting system.

As the mallee industry is still in its infancy, many lessons can be learnt from the mature sugar industry. It will be important for the mallee industry to consider whole-of-system performance to ensure components of the supply chain work efficiently as an integrated system. The availability of a prototype harvester provides an opportunity to evaluate machine performance and assess critical parameters across the supply chain.

The prototype mallee harvester performs the basic functions of gathering, severing stems at ground level, feeding all the woody (trunks, stems, branches etc) and leafy biomass (foliage, leaves etc), through a chipper system and delivering the chipped product into infield transport. There is no debarking or separation of leafy biomass from woody biomass during the process.

The prototype mallee harvester incorporates a platform vehicle to power and propel the machine and an attached harvester head arrangement. The harvester head is a single row, over-the-row arrangement. The prototype mallee harvester is aimed at stems up to 15cm diameter. Alternative systems (e.g. feller/buncher) will be required as age of tree and size increases.

The current platform vehicle is a Claas Xerion utility tractor. The current prototype mallee harvester is limited by available power. Hence, future prototypes may not utilise the Claas Xerion as the platform vehicle. Manoeuvrability and associated soil compaction issues will need to be considered in the selection of the propulsion system (tracked or wheeled configuration) of the platform vehicle.

The prototype harvester in trials to date has achieved a maximum continuous pour rate of 35 tonne/hr. The maximum pour rate achieved in trials was 38 tonne/hr for a short period. A continuous machine pour rate in the order of 60 tonne/hr is required for a viable harvesting system.

Bulk density is a very important performance parameter for an efficient harvesting and transport system. Bulk density changes with tipping and transport, and the associated impact on product handling has not been determined. Similarly, the effect of product composition on bulk density is not known definitively, but experience to date demonstrates that whole mallee biomass and clean pulp wood chip have similar bulk densities, so the influence of biomass composition appears to be minor. However the quality of the chipping process – the quality of cut – could potentially have a significant impact upon material handling properties, and possibly some influence upon bulk density.

There are significant losses from mechanical harvesting of sugarcane, with the majority of losses occurring in billeting and separation of trash from billets. There is no quantitative data on losses during mallee harvesting as the prototype harvester has not undergone commercial testing but preliminary observations are that it should be low. The main loss processes would include gathering, chipping and spillage during transfer to the infield transport. As there is no separation of the product on the harvester, there are no losses from this process like in sugarcane harvesting.

Transport efficiencies may be possible by leaving residue materials such as bark and twigs behind in the paddock, but if there is a high enough value for residues, for example as a bioenergy feedstock, then transporting the mixed biomass will be acceptable. In addition, separation on the harvester has a low chance of success and will result in a more complex machine design and product losses in field. A better strategy may be to utilise semi-mobile equipment to undertake product separation at nodes close to the biomass source and then transport different products to different markets.

Sugarcane harvester field efficiencies are typically 30% to 50%, whereas for mallee, modelling indicates field efficiencies could be 70-80%. This is the consequence of long row lengths and slow harvesting speed, resulting in a reduced number of times the harvester needs to turn per hour of operation and per tonne harvested.

The dispersed nature of the mallee crop will have a significant impact upon field efficiency, with yields per paddock hectare of less than five tonnes per hectare, and typically around one green tonne per hectare. Infield haul distances will be relatively long and vary widely over short periods, which will make the logistics of harvesting and hauling complex. To simplify this part of the process, the introduction of a

shunt truck between the haulouts and the road transport is under consideration, as it should allow the harvester and its associated haulouts to work closely together and introduce important flexibility into the farm operations.

Harvest timing is restricted to the winter and spring seasons in Australian sugar cane, whereas mallees could, with some qualifications, be harvested all year. This changes the scale of operations significantly, in that a one million tonne per season sugar mill processes at the rate of about two million tonnes a year. In comparison, a large bioenergy conversion factory might require about 100,000 to 200,000 green tonnes of biomass over a whole year. While mallee road transport logistics will consequently be relatively simple, the dispersed mallee crop and long infield transport distances will make on-farm logistics relatively complex and expensive. Extensive use of sugar cane logistics and harvester monitoring systems will help the new mallee industry.

The mallee industry will also benefit from the comparatively stable nature of the ex-harvester product. Green biomass can be stored for periods of a few days, and after upgrading and drying the finer components of the biomass, storage of weeks should be feasible. This is a significant point of difference with sugar cane which has cut-to-crush intervals of only hours, which makes the logistics of a mill's supply chain complex.

Payment systems and business structures vary in sugar cane and provide a range of models from which a new mallee industry will be able to choose. The new industry has the opportunity to set itself up so that responsibilities and rewards are properly aligned and the value added along the supply chain can be appropriately shared amongst the participants – to increase the size of the cake for the benefit of all.

At equivalent pour rates, the cost of sugarcane harvesting is less than half that of the estimated cost of mallee harvesting. The actual cost of mallee harvesting is unknown but modelling a hypothetical system using the Harvest Haul Model (Sandell and Prestwidge 2004) for this project demonstrates the importance of pour rate and tonnes per harvester per year in reducing per tonne costs. The high power requirement for mallee chipping and the low speed at which harvesters can travel while cutting trees will limit the capacity of the new industry to reduce per-tonne costs.

Key considerations regarding sugar and mallee harvesting systems and the impact on the supply chain are tabulated in Appendix 1 of the document.

2.9 Recommendations

Increasing harvester performance will be critical to reduce harvesting costs. Key information that should be collected when the harvester commences full scale infield trials in order to inform decisions on improved harvesting systems includes data on material bulk density and whole-of-system performance. Information on losses which will include leaves, branches and twigs expelled during felling and feeding should be evaluated and quantified.

Consideration will need to be given to appropriate tipping and pouring options. Harvester and chipper design could be impacted in terms of chip size and the trade-off between chipping costs (chip size) and transport costs (packing and bulk density).

Consideration will need to be given to ways to improve pour rates and efficiencies. This could inform changes to the mallee row arrangement to better suit commercial harvester and transport constraints. Harvester operation and production appears optimised if mallees are close together (<2m spacing) in 3m spaced rows.

Further work on supply chain analysis and logistics is recommended to ensure that the scale of the supply chain components is appropriate and work efficiently as an integrated system. The mallee industry can draw on the experiences and lessons from the Sugar industry in respect to capacity planning, scheduling and harvesting payment structures.

3. Transport and Storage Systems

Transport chains are a key link in an agricultural commodity system supply chain and an efficient transport system is critically important for efficient agricultural commodity marketing. Transport can no longer be considered as a separate service that is required only as a response to supply and demand conditions. It has to be built into the entire supply chain system, from harvest to processing. This is best brought about by an efficient, high volume, transport system where the transporting unit costs are low. The proportion of transport charges to final market price will vary with the efficiency of the transport sector.

The presence of an efficient agricultural commodity transport system is sustained by:

Functional integration. Its purpose is to link the elements of the supply chain in a cohesive system. Functional integration relies on the freight management strategy (e.g. just-in-time, warehousing, transshipment), the transportation mode (e.g. road) and transportation equipment.

Geographical integration. Resource consumption may be reliant on supply sources that are distant. The need to overcome space is fundamental to an economic and sustainable system. The transport system developed must integrate geographically separated regions.

Logistics performance. Logistics have a major impact on economic activity. Logistics performance relies on route optimisation, coordinated transport and integrated logistics methods.

All transport systems have component parts and processes. The way the transport system functions is the result of the interaction of these elements at harvest time. The components and processes of a biomass transport system are outlined in proceeding sections with comparison to the transport system of the Australian sugarcane industry.

A change to any element of the transport system will also have an impact on the other elements of the production system.

3.1 System Overview

Sugar System

Harvested sugarcane is delivered to the mill via infield transport and road and/or rail transport. Transport from the siding to the factory by road and/or rail transport (including the cost of their railway infrastructure) is 30-40% of the total milling cost (ASMC, 2008).

A number of mills (three in Queensland, three in New South Wales) do not have railway systems and rely on road transport for cane deliveries. Some mills with rail systems rely on road transport for the delivery of a proportion of their cane. However it is recognised that rail transport is the most economical transport method where tonnages are sufficient. However, they require large capital for set-up and have high maintenance costs.

Queensland's cane railways (tramlines) annually transports harvested cane over about 4,000 km of mostly 2 foot (610 mm) gauge privately (mill) owned track. Rolling stock consists largely of cane bins which are box-like containers on wheels, often constructed from tubular steel with wire mesh sides. These vary in capacity from 4 tonnes to 14 tonnes. Four-wheel bins range up to 10 tonne capacity, while bogie designs are used for larger types. There are over 50,000 cane bins in use across the industry, to transport the chopped cane during the crushing season. The furthest run from a pick-up point to a mill is 119 km and the average distance hauled ranges up to 35 km. Trains can run at 40 km/h and can be up to 2,000 tonnes in weight and one kilometre in length.

For the purposes of this study, no further consideration of the rail system will be undertaken.

Mallee System

An economic analysis by Olsen et al. (2004) concluded that the low rainfall (300-600 mm) wheatbelt environment will only support low levels of woody biomass production per square kilometre over the landscape as a whole. Further, typical paddock sizes vary from 100 ha to 1,000 ha. The amount of biomass will be modest in the short and medium term, however in the long term, the removal of up to about 10,000 green tonnes of material from a medium sized farm covered with 10% mallee may be achievable (Giles and Harris, 2003).

There is general agreement that to meet its challenging operating cost target, the mallee supply chain should be continuous so that there is no temporary storage (other than very short term surge buffers in bins) involving an unload/reload step from harvester to the processing plant (Bartle and Abadi, 2010). Hence, the chipped mallee will be delivered to the processing facility via infield transport and road transport.

Materials handling must be very efficient to fit within the economic constraints of the whole production and processing system.

3.2 Infield Equipment

Infield transport, sometimes called on-farm haulage or forwarding, refers to the transfer of biomass from the harvester to a delivery point for loading on to transport to the processing facility. It is an important part of the supply chain and has been shown to be one of the major components in the delivered cost.

Sugar System

Billeted sugarcane is directly loaded from the harvester into following infield transport equipment in the field. The infield transport follows the harvester whilst filling, then swaps with an empty transport to allow the harvester to continue work. The purpose of the infield transport equipment is to transport material from the harvester to the receival point for the long distance transportation system. This is usually a rail siding or road transport pad. At the receival point the sugarcane is transferred to the railway or road transport bins. As such the infield equipment only travels relatively short distances (<3 km) round trip, mostly on farm paddock headlands or internal farm roads (non-gravel and/or gravel). Almost all infield equipment at some point during the harvest season will access the sealed road network. Under these circumstances these vehicles require conditional registration. The infield transport equipment is commonly referred to as 'haulouts' throughout the industry.

Transport of sugarcane from the field to the rail siding or road transport pad is a cost paid by the grower.

Mallee System

The mallee system will be an analogue of the cane system, with the use of haulouts to chase the harvester and transport the chipped biomass to the field edge. Because of the relatively large paddock sizes in the wheatbelt, and the low productivity per paddock hectare, the ability to construct the equivalent of a cane road transport pad(s) in every paddock will be limited, as the pads will be used infrequently and for modest amounts of material. For the same reasons, the use of on-farm storage will need to be minimised as the cost of reclaiming the biomass from stacks on the ground would be significant if another machine, such as a wheeled loader, was to be introduced into the supply chain.

The introduction of a two-stage field transport system is under consideration. The high cost of owning and operating haulouts makes them only suitable for short distance transport in the paddocks. At the same time, the potential problems of bringing road trains into the paddocks without properly formed and stabilised pads and secure access off all weather roads will make it difficult to consistently and reliably directly link the road and infield systems without significant expense. A third stage of

transport, which has some infield capability and a high road speed, could be used to link the haulouts with the road system. The road transport receipt points or landings could be spaced over 10 km apart, which would increase the tonnage passing over each landing each year and so make road transport landing preparation more affordable. Landings could also be located opportunistically, on suitable soil types or even use existing sites like abandoned railway sidings, making site stabilisation and paving unnecessary or only a modest cost.

3.2.1 Configuration

Sugar System

Billeted sugarcane infield haulout equipment has evolved from single 3 tonne roll-on/roll-off rail bins carried on trailers drawn by standard farm tractors to dedicated self-propelled units often carrying in excess of 14 tonnes of cane. The current range of sugarcane haulout vehicles is the result of many evolutionary changes, some of which were not appropriate for the industry.

Harvesting of sugarcane in Queensland and in Northern NSW has, in the past, posed many problems in wet fields. Following heavy rain, mobility and manoeuvrability have been restricted and deep rutting has resulted. Full-track (e.g. steel and rubber) equipment and high flotation tipper bins (tracked or tyres) and tipper-elevator bins have been developed by manufacturers to improve operating efficiency.

Rubber-tracked vehicles have lower maximum haul distances (2-4 km) than wheeled vehicles (5 km or greater). The rubber tracked infield vehicles still have some limitations as trailer track life of less than one season has been reported. This is mainly due to high number of turns required. However, rubber track designs are continually improving. For NSW harvesting conditions, a set of rubber tracks have a life expectancy of approximately three seasons for two haulouts operating on a 750 m averaged haul distance (12 500 km track life for both haulout and tractor).

There are various combinations of infield haulout equipment in use throughout the sugar industry. These include drawn (e.g. tractor, Cat Challenger, JBS Fastrack) and self-propelled. A feature of the Australian sugarcane industry has been the extensive-use of self propelled haulouts. Similarly, there are various combinations of containment and unloading mechanisms. These include roll on/roll off railway bins, mesh sided bins with side tipping capability (side tippers) to bins with end lift and cross elevator unload (elevating tipper bins).

Average speeds for the rubber tracked machines are about 25 km/hr unloaded and 20 km/hr when loaded. Tractor drawn vehicles have operating speeds of about 40 km/hr unloaded and 30 km/hr when loaded. There are self-propelled vehicles which can travel at speeds in excess of these speeds (up to 60 km/hr unloaded).

Maximum allowable loading for public road usage of rubber tracks in NSW have not been determined. To date, compliance requirements of cane bins equipped with rubber tracked vehicles in NSW has been restricted to issues of dimensions, brakes and lights. As RTA NSW regulations do not allow concessional axle loadings for wheeled sugarcane haulouts fitted with high flotation, low pressure tyres, it is realistic to assume that a maximum allowable pavement load for rubber tracks of significantly less than the 28 tonnes allowed in Queensland.

Various examples of the combinations of infield haulout equipment in use throughout the sugarcane industry are outlined.

The truck mounted rail bin still used in the Burdekin mill areas where long rows require high efficiency transport.

Various side tipping and end lift configurations are in use as shown in Figure 3. and Figure 3.2.



Figure 3.1 Tractor drawn side tipper

A side tipping configuration is:

- simple and relatively inexpensive compared to elevating tipper
- quick to unload (about one minute)
- preferred system with multi-lift bins as they do not have the bin size match problems of many Queensland tramway systems.



Figure 3.2 Tractor drawn trailer with end lift and cross-elevator unload



Figure 3.3 Articulated self-propelled with end lift and cross elevator unload



Figure 3.4 Tracked rigid self-propelled with side tipper

Rigid self-propelled haulouts are generally of older designs and often built by contractors or by CNH Austoft up until 2004. They have been gradually superseded by articulated units Figure 3.. Figure 3.5 illustrates a 2000 model CNH Powerhaul transporter.



Figure 3.5 Self-propelled with side tipper (power haul)

Elevating tipper bins are popular in Queensland mill areas where the infield haulout must fill mixed bin sizes that may vary in size (e.g. 6 t and 10 t rail bins at the same siding). The elevating tipper bins can also top-up rail or road transport bins to maximise loading efficiency. However, elevating tipper bins have a higher capital cost, higher maintenance costs and are slower to unload when compared to side tippers.

There are various manufacturers of dedicated sugarcane haulout equipment across the industry. Table 3. provides a list of sugarcane haulout equipment manufacturers.

Table 3.1 Sugarcane haulout equipment manufacturers

Manufacturer	Location	Equipment Type	Contact
Carta & Co Pty Ltd	Ingham	Elevating Tippers	07 4776 5362
Corradini	Ingham	Elevating Tippers	07 4776 5225
EHS Manufacturing	Mackay	Side Tippers	07 4959 8880

Mallee System

As mallee is spread geographically across the Western Australian wheatbelt and harvesting will be a year round operation soil conditions will vary widely, both spatially and over time. The Mediterranean climate zones can see unstable soils become commonplace during winter. Therefore, vehicles used for infield haulout will need to be suitable for off-road use and have low ground pressures. Depending on the row configuration and because of the low stumps are left by the harvester, rubber tracks will be preferable to low flotation tyres (Giles and Harris 2003).

A variety of infield transport systems have been considered over the years it has taken to develop a mallee industry supply chain. There are a number of basic requirements:

- The harvester will not have any on-board storage capacity or tow its own bin. A commercial harvester will be a large machine on its own and adding a large volume bin would make it a very cumbersome machine. Also the time required to transfer a bin-full of biomass to a haulout will significantly reduce upon the field efficiency of the harvester.

- With relatively long infield haul distances, haulouts will need to have high payloads and relatively high speeds.
- Whole-tree biomass is difficult material to transfer from vehicle to vehicle. It is most similar to silage, so it does not flow or auger from the bottom of a bin like grain, and conveyors themselves can be difficult to load from a bulk mass. The mass has to be torn apart and fed incrementally onto the conveyor to avoid blockages.
- It is unlikely that whole tree biomass will be readily tipped from one bin to the next. Tipping is feasible in itself, but as discussed previously in Section 2.3.3, tipping is expected to lead to significant losses in bulk density.
- Short term surge buffers in bins or on trailers will be required between the infield transport and the road transport stages to enable maximum field efficiency for the harvester. The problems of limited surge capacity between stages were identified by McCormack et al (2009) as one of the most significant weaknesses of the supply chain.
- Road transport will be in multi-trailer truck configurations and terminal time (loading and unloading time) must be minimised. This makes loading and unloading over the side of road trailers necessary, and to avoid the need for another machine in the supply chain, the road trailers need to be able to load themselves, or be loaded by the haulouts.

Not all the key parameters have been tested at this point, and most importantly the effect of tipping bin-to-bin is yet to be quantified. If as expected tipping causes unacceptable loss of bulk density, then a system based upon containers is most likely to be adopted. This will place additional requirements upon system design:

- Containers will be filled at the harvester and passed along the supply chain undisturbed until emptied at the processor's receipt point.
- Containers must be matched to the size of the road trailers as there is no practical method of self-loading two containers over the side of one road trailer.
- A road trailer has a payload of 25 - 28 tonnes, depending upon tare weight, so bins of about 70 m³ volumetric capacity will be required. This indicates larger haulouts will be necessary than are currently employed in the sugar industry. A conceptual haulout configuration is presented in Figure 3.6.
- Haulouts matched to side-loading trailers (similar to the swing-lift loaders used for shipping containers) will also need to be self-loading and unloading.

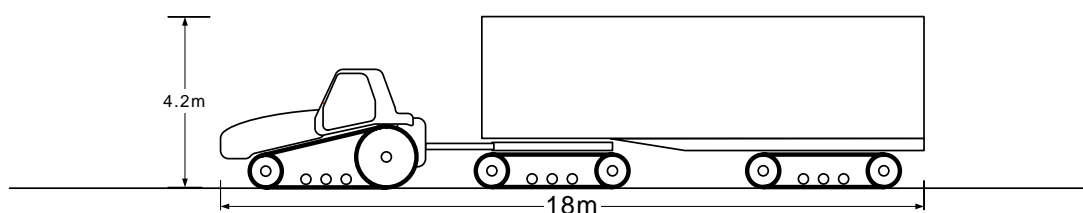

Figure 3.6 Conceptual haulout configuration with a 70 m³ bin

In the introduction to Section 3.2 the option of using shunt trucks was raised as a way of introducing operational flexibility into the system and allowing infield transport to focus upon short hauls to the field edge. If shunt trucks are employed, they will be similar to road truck configurations, with a prime mover suitable for operations in most paddock conditions, but without the whole-of-paddock capability of the haulouts. A shunt prime mover could be either a fast tractor or an 8x8 truck prime mover.

It appears that bins will be the surge buffer at landings, similar in principle to the multi-lift bins used in the NSW sugar industry (Figure 3.1). The multi-lift bins are ideal where single trailer trucks must be employed and road transport distances are relatively short. However multi-trailer trucks lose efficiency

due to increased terminal time where they must be loaded and unloaded over the rear of the trailers as the road trains have to be separated and reassembled both at the loading and unloading stages.

3.2.2 Capacity

Sugar System

For side tipper and elevating tippers, there are various vehicle sizes from a nominal 8 tonne to nominal 14 tonne capacity. Most units are of local manufacture and unique in design and thus vary between regions, with the configuration usually depending on the transport system to the mill (rail/road). The physical size of haulouts is governed by overall height (3.5m) and width restrictions (2.5m). Width is a critical road dimension continuous operation of over-width cane haulout vehicles of public roads is not permitted. Hence, the actual dimensions will vary depending on height from the ground (tracks, high floatation tyres etc).

Table 3.2 provides data on typical dimensions and capacities of various sugarcane haulout vehicles.

Table 3.2 Examples of sugarcane haulout capacity

Manufacturer	Bin Dimensions			Volume	Nominal Capacity
	Length	Width	Height		
	m	m	m		
Tractor Trailer	3.8	2.3	2.4	21	8
Tractor Trailer	3.5	2.4	2.7	23	9
Austoft Powerhaul	4.8	2.3	2.7	27	10
Tractor Trailer	4.3	2.4	2.7	28	12
Self-Propelled	6.4	2.3	2.5	36	14

Robotham et al. (2001) obtained various data from a range of sugarcane haulout vehicles. They developed a simple load index to help quantify the efficiency of the haulout vehicles as load carrying machines. This load index was defined as vehicle payload divided by gross vehicle mass. An efficient haulage vehicle would have a load index of 0.5 or greater whilst an inefficient haulage vehicle would present figures of around the 0.2. Figure 3.7 illustrates the best and worst gross mass carried compared with load and tare weights for sugarcane haulout vehicles.

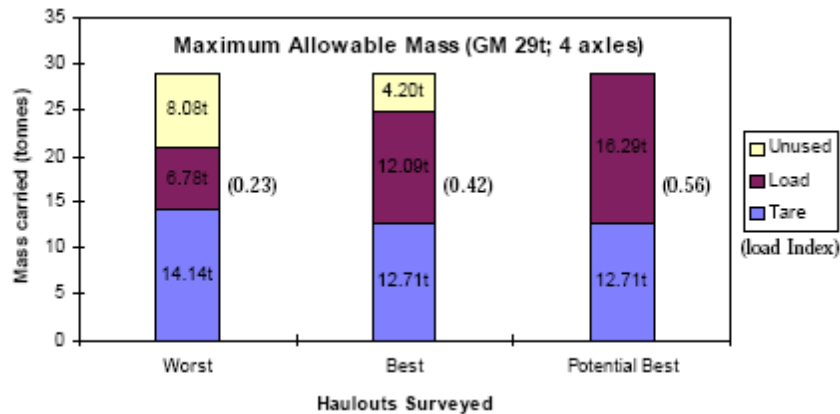

Figure 3.7 Gross mass compared with load and tare weight of haulout vehicles in the sugar industry (Robotham et al. 2001)

Table 3.3 shows the load index measured by Robotham et al. (2001) along with a comparison with other vehicles. From their study, the worst tractor/trailer classification had a load index of 0.23 or had a tare weight of about 14 t for a load of less than 7 t. This vehicle has about 8 t (29 – 14 – 7) of its allowable load carrying capacity unutilised. The best tractor/trailer units carried a load almost equal to their tare weight. The potential best unit is assumed to have the same tare weight as the best measured but carried a greater load through improved load distribution onto all axles. The potential best vehicle had a load index of 0.56, which is considered quite achievable.

Table 3.3 Haulage vehicle load/gross mass ratio

Vehicle	Load/Gross Mass Ratio
Tractor/Trailer	0.23 – 0.42
Rigid	0.29 – 0.31
Articulated	0.29 – 0.42
Construction Tipper	0.55
Semi-Trailer	0.62
Grain Chaser bin	0.57

Mallee System

The haulout capacity must be as large as practical as this is the smallest batch process. With a tipper system the bin capacity must be half or the same capacity as the road transport. McCormack et al. (2009) showed that the benefit of larger bins is greatest for systems which have higher harvester cutting rates.

As haulout distances will be relatively long, payloads will need to be large. Tipping from bin to bin is not preferred, so haulouts with half a road trailer capacity of around 35 m³ are unlikely, and a single trailer with a capacity of around 70m³ will most likely be investigated. This size should give a payload of around 28 t at a bulk density of 0.4 t/m³.

A combined tare weight for a tractor and large trailer plus a bin, as depicted in Figure 3.6 might be about 30 tonnes, which would give a load/gross mass ratio of about 0.45.

3.2.3 Haulage cost and fuel consumption

Sugar System

Haulage costs have been examined in relation to transport speed and distance, as described in Figures 3.8 and 3.9. The influence of payload will be similar to that observed for speed as these are the two principal influences upon transport costs.

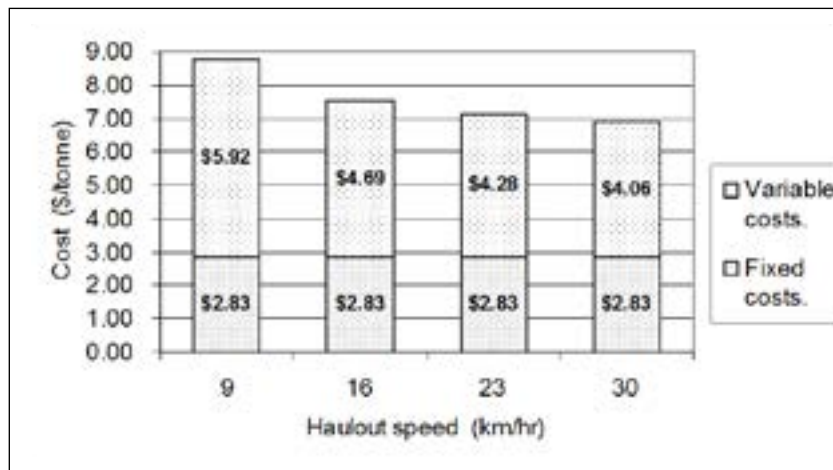

Figure 3.8 Effect of haulout speed on infield transport cost

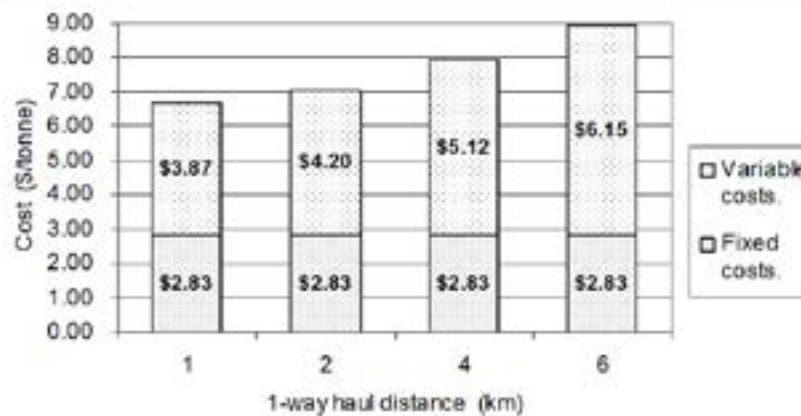

Figure 3.9 Effect of haul distance on infield transport cost

Haulout fuel usage is directly related to the average distance that the biomass must be hauled from the harvester to the receival and hence is dependent on machine size, distance, payload and farm and operational factors. Clearly, factors such as engine size, row length, distance to siding and a range of external factors dramatically impact on fuel consumption/tonne harvested. Haulout fuel usage is rarely separated from total harvesting (harvester + haulout) fuel usage. A harvesting operation usually has a minimum of two haulouts per harvester. Three or more haulouts may be used for long haul distances.

Fuel usage is expressed as fuel used divided by the total tonnes cut over an extended period.

The engine size of haulouts varies widely. Tractors / trailer combinations require a tractor around 150 Hp (110 kW) drawbar power. The typical engine power range for self propelled is between 180 Hp (136 kW) to 220 Hp (165 kW) for 12 -14 t capacity.

Willcox et al. (2004) measured the average fuel usage for haulout vehicles under green cane and burnt cane conditions in the Maryborough, Mackay and Ingham regions in Queensland over a two year period. They measured total fuel used per day and divided it by the total tonnes cut for the day.

Table 3.4 shows the effect of haul distance on haulout fuel usage for two contractors in the Mackay region. These data clearly shows the impact of larger equipment and increased haul distance on fuel usage. Whilst the elevating tippers are larger capacity, the side tipping trailers have a quicker turnaround time and smaller power plant.

Table 3.4 Effect of haul distance on haulout fuel use (Willcox et al. 2004)

Haul Distance m	Fuel use	
	Mackay*	Mackay**
	L/T	L/T
500	0.34	0.71
1000	0.39	0.72
1500	0.44	0.73
2000	0.49	0.74
2500	0.54	0.75

*2 x 10 t tractor drawn side tipping trailers with JCB tractors.

**2 x 15 t tractor drawn (JCB Fastracs) elevator tippers.

Figure 3.10 shows data collected from harvesting contractors in the Mackay region. This shows that haulout fuel use is less than 50% of harvester fuel usage. Willcox et al. (2004) from a study of harvesting operations in the Maryborough region showed that haulout fuel usage is about 53% of the harvester fuel usage.

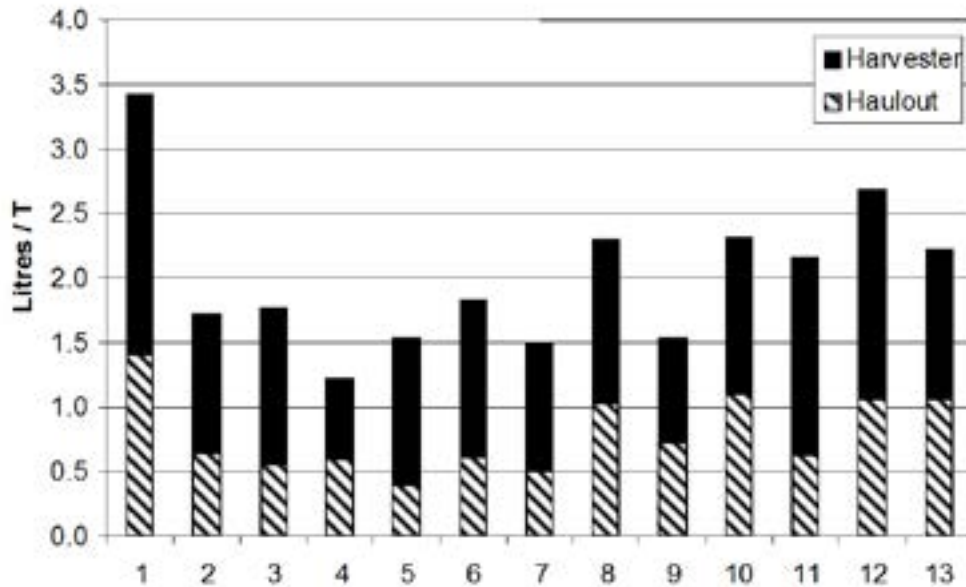

Figure 3.10 Haulout and harvester fuel use (Sandell and Agnew 2002)

Mallee System

As a proven system robust enough to harvest mallee has not yet been developed the exact configuration of haulout vehicle is not known. Hence, the actual cost of the infield transport component is unknown.

However, McCormack et al. (2009) in their model investigated the effect of haulout travel speed, transport distance and bin size on haulage costs.

Figure 3.11 shows the influence of bin size and haulout speed upon the cost of infield transport, with costs ranging from \$6 to \$12 per green tonne. The cost is equally sensitive to both variables.

Figure 3.12 shows the influence of infield transport distance upon cost, and compares this with the effect of pour rate. Estimates range from \$5 to \$12 per green tonne, and pour rate is much more influential upon the cost of infield transport than distance, because even at short transport distances, the harvesting system still requires two haulouts. Fuel, repairs and maintenance vary with the amount of work done per shift, but other costs are either effectively fixed on a daily or shift basis or fixed annual costs.

Fuel use estimates for infield transport vary from 0.9 l/gt to 1.9 l/gt according to the assumptions about transport speed, distance and payload. These values are very sensitive to the details of operation, such as the proportion of time the haulouts spend under load at the rated engine speed, but it would be reasonable to assume that with longer transport distances, fuel use would be higher than the observed values in sugarcane. There is some potential for relatively good efficiency if the larger payloads lead to a better vehicle load to gross mass ratio with large mallee haulouts.

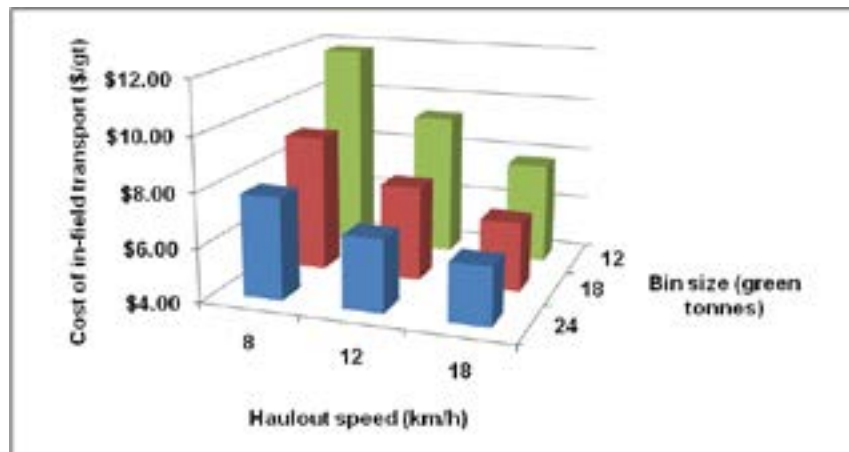

Figure 3.11 The effect of haulout travel speed and bin size on infield transport costs (McCormack et al. 2009)

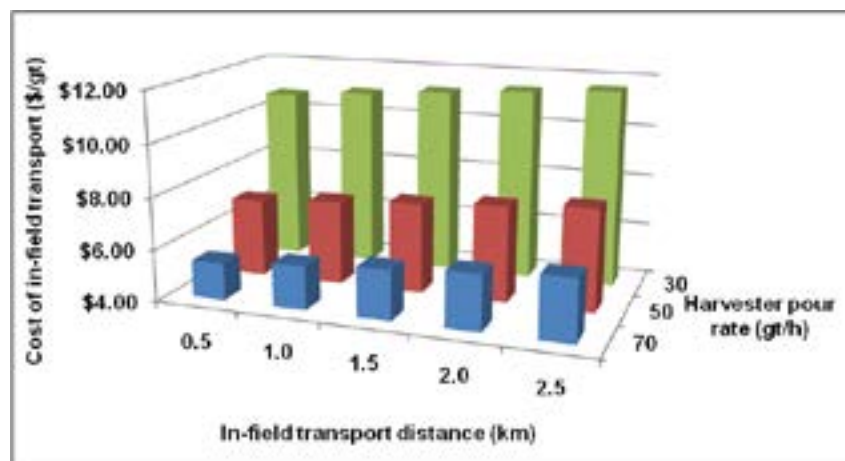

Figure 3.12 The effect of transport distance and harvester pour rate on infield transport costs (McCormack et al. 2009)

3.2.4 Conditional Registration

Sugar System

In Queensland, conditional registration is a registration scheme for non-standard vehicles that do not comply with the standard regulations for registration and have a genuine need to access the road network. Conditional registration provides compulsory third party insurance in the event of a crash occurring on a road causing personal injury.

Most agricultural vehicles are non-standard and therefore must be conditionally registered. The Queensland sugar industry has worked closely with the Department of Transport to ensure that infield haulage equipment are included under the conditional registration scheme. The Queensland Department of Transport provides guidelines for the conditional registration of three categories infield sugarcane transport equipment. These include:

- Transporter - Sugarcane Infield – Wheel
- Transporter - Sugarcane Infield – Tracked
- Transporter - Sugarcane Infield – Excess Length

For each category of infield sugarcane transport equipment there are three options of road access allowable under conditional registration. These include;

- Limited access registration — vehicles are predominantly restricted to worksites and designated areas.
- Zone access registration — vehicles are allowed to travel on road for distances of 20 kilometres (km), 40 km, or 80 km depending on their areas of operation in Queensland.
- Unrestricted access registration — appropriate vehicles will be allowed unlimited access, but may still have conditions that apply to the time of operation.

Mallee System

As transport regulations vary from state to state, licensing of infield transport that travel on public roads may be required. This will involve the mallee industry working with the WA Department of Transport and other transport regulators in each of the states to define appropriate guidelines for conditional registration.

In the regions where mallees are grown, oversize farm machinery is commonly driven on public roads, such as contract grain harvesters that are overwidth, and towing long combs, that travel the north-south extent of the Queensland to Victoria grain belt. These also tend to be the regions where vehicles are permitted the greatest overall length. This may be in contrast with the sugar industry which is located along the eastern seaboard often in close proximity to urban and semi-rural lifestyle properties. However there will be need to consult with the various transport regulators, especially with regard to technical issues, for example, the use of high speed tractors towing large capacity trailers in road train configurations.

3.2.5 Discussion

In sugarcane systems the cost of infield transport varies up to \$9 per tonne according to distance and speed when these factors are analysed individually. Haulout fuel use is about 50% of harvester fuel usage.

Modelled estimates for mallee indicate that infield transport will cost about 75% of the per-tonne cost of harvesting, and haulouts will use about 60% of the fuel used by the harvester. These proportions reflect the assumptions that the two haulouts combined are almost as capital intensive as the harvester and there are two haulout operators for every harvester operator. Harvesting will also be particularly energy intensive (due to the chipper) and a haulout does not need to operate under full load while returning empty to the harvester or waiting while the other haulout is being loaded. Monitoring of all fuel use should be considered when a commercial system is developed.

The mallee industry should consult with the transport regulators in all states to define appropriate guidelines for conditional registration if required.

3.3 Road Transport

3.3.1 Configuration

Sugar System

The most common type of road transport is the multi-lift semi-trailer carrying one single multi-lift bin at a time. Figure 3.13 illustrates the multi-lift bin. With this configuration the semi-trailer unloads the multi-lift bin onto a level surface (usually a dedicated pad). The infield haulouts load straight into the multi-lift bin as shown in Figure 3.1. This system is in use in all NSW mill areas and predominant in Bundaberg and in North Queensland on the Atherton Tablelands. The cane is unloaded from the bin

whilst the bin is on the multi-lift trailer. To unload the cane from the bin, the multi-lift trailer is hydraulically raised from the front and the rear door of the bin pivots from the top of the bin and is manually opened. The cane exits under gravity from the rear of the bin.



Figure 3.13 Multi-lift semi-trailer bin

In other areas with road transport (e.g. Maryborough, Mossman) there are semi-trailer combinations of multi-lift bins and direct loading of multiple roll on/roll off railway bins or B-Double trailers capable of carrying three, 12 tonne transfer bins.

NSWSMC when evaluating materials handling options for whole-of-crop harvesting investigated several alternate systems including the German, Fliegl Gigant push-off trailer (see Figure 3.14). Whilst of interest, such units require a complete change in the materials handling equipment as they were not compatible with the existing multi-lift system. High capital cost and potentially greater unloading times were additional reasons why NSWSMC did not pursue these types of systems. NSWSMC did not consider side tipping trailers as this did not suit existing unloading configurations at the mill.



Figure 3.14 Fliegl Gigant push-off trailer

3.3.2 Capacity

The current multi-lift bin used in QLD has a volume of 65 m³. This was also the size of the multi-lift bins in all NSW mill regions in NSW prior to 2008. With a 65 m³ multi-lift, the maximum allowable payload under RTA NSW axle loading regulations is achieved with burnt cane with less than 100 % volume utilisation. For whole-of-crop harvesting, NSW SMC has replaced their steel framed 65 m³ multi-lift bins with imported low tare weight, aluminium 90 m³ bins at Condong and Broadwater mill areas. Harwood mill still uses steel framed 65 m³ multi-lift bins. The tare mass of the aluminium multi-lift bins is about 4.25 t. The aluminium bins have not been trouble free. The main issue is damage from side tipping haulouts catching on the side of the bin during unloading.

Mallee System

The product to be transported has bulk density and similar flow characteristics to burnt cane, and a road system suitable for road trains already exists throughout the WA wheatbelt for cartage of wheat. However, these systems use end tipping trailers and grain trailers do not have sufficient volume for mallee biomass. Side tipping road trains are considered essential for chipped biomass to avoid the problems of end tipping. For some free-flowing products, such as wheat, this can be accommodated by tipping through a grizzly screen into a pit. However, whole chipped mallee does not flow as well. It cannot be tipped over the drawbar of a second trailer or through a grizzly screen, and if tipped over the side it must be tipped clear of the trailer wheels.

Road trains and B-doubles seem more likely than single semi-trailer as mallee crops are most likely to occur in low rainfall areas. Road transport of bulk materials in WA has become focussed upon two trailers (27.5m overall length) to give an extra axle group beyond the B-double. Hence, a configuration that allows side unloading of two trailers is essential.

There are systems that collapse B-doubles into one long bin, opening the A trailer into the front of the B trailer, and then tipping the whole truck on a tipping platform. These whole truck tipping systems are expensive compared to tipping sideways into a pit, but they permit deliveries from a variety of existing transport trailers that all tip over the rear. Bowl door tippers are common place in bulk transfer of materials in the construction industry. However, as it will be difficult to tip from a large capacity infield transport into a road trailer, and breaking up and re-assembling two-trailer configurations will be less productive in short haul situations, a containerised system may be most appropriate. A containerised system also avoids the problems anticipated with reduced bulk density when whole tree biomass is tipped from bin to bin (see section 3.2.1).

Figure 3.15 shows an example of the basic vehicle configuration that may be used for mallee, but this truck uses standard rear tipping trailers. Some design and analysis will be required to determine if containers with similar dimensions and the same volume per trailer could be used, loading and unloading with a swing-lift system as employed for sea containers. In some regions (such as central and western NSW) modified sea containers could be used for biomass, with two 12.2m trailers in road train configuration, but in the south west of WA trailers will be restricted to about 9m length for an overall vehicle length of 27.5m.



Figure 3.15 Standard two trailer chip transport with rear tipping trailers

3.3.3 Heavy vehicle regulations

Sugar System

Road transport vehicles need to conform to New South Wales and Queensland heavy vehicle regulations. Road regulators from both States describe sugarcane as a divisible load and hence haulage operators are required to limit loads through adjusting the amount of material placed in the bin. Applications for permits to operate over-mass do not receive favourable consideration.

The multi-lift bin system is mass limited not *Mallee System* volume limited.

Road transport vehicles need to conform to Western Australian heavy vehicle regulations. Whilst there are moves to make road transport regulations uniform nationally there are likely to be local variations.

3.3.4 Transport Costs

Sugar System

There is little published data on road transport costs of sugarcane. Data provided by industry indicates that the average cost of transporting cane to the mill in NSW is about \$5.00 to \$7.00 per tonne. The trucking distances are relatively short with an average trucking distance from pad to mill in NSW about 27 km one way. In the Broadwater mill region the longest trip would be about 100 km one way.

Mallee System

Due to the geographic spread of mallee plantings, the average trucking distance to the processing plant would be in excess of 100km. It is assumed that with development of the industry and greater concentration of the resource with new planting, the average distance will decrease, but for several years the industry will need to begin operations with the longer transport horizon.

Yu et al. (2009) estimated a road transport rate of woody chips of approximately \$0.10 per green tonne per km which was confirmed by several professional truck drivers in the wheatbelt for their modelling. Recent communication with grain transport companies have confirmed 2011 prices in the range of

\$0.10 to \$0.12 per tonne per kilometre for distances in excess of 100km one way. An important characteristic of grain transport is that the road trains do not normally need to be broken up for loading or unloading, so terminal times are short.

The product most like whole tree biomass, wood chip, is an expensive product to transport compared to grain. The industry standard cost is \$0.17 to \$0.18 per tonne per kilometre for pulp wood chip and the difference from grain is due to the terminal time imposed upon wood chip transport by other characteristics of the supply chain and historical factors.

Loading of chip trucks at the roadside is typically done by the chipper, as shown in Figure 3.14, and a large chipper normally takes about 40-50 minutes to load a road train. Because the chipper is the most expensive machine in the system (commonly about \$800 per hour), there is often a small queue of trucks at the chipper to ensure it is operating as continuously as possible.

Unloading over the rear by tipping or walking floors is the industry standard for wood chip and the delivery points at ports are all set up for rear discharge trailers. Tipping can be either tipping trailers or whole-truck tippers. No transport contractor is able to adopt side tipping because there are no suitable side-delivery pits – a similar situation to that noted in relation to the sugar mills in NSW in section 3.3.1. With two trailers, observations at a number of sites confirm that uncoupling and reassembling road trains, plus separate tipping of each trailer, takes about 40 minutes. Shorter times can be achieved with whole truck tippers if there is an attendant on hand to assist in uncoupling/recoupling the rear trailer, but this system can only be justified by high volumes of deliveries, for example at a chip export port facility.

In the case of mallee, margins will be relatively small, so chasing cost savings of only \$2-\$3 per tonne is important, and there is the opportunity to start with a blank slate and avoid historical constraints. Side loading is essential and if a containerised system is adopted this should be achievable with swing-lift trailers. Unloading by side tipping should also be feasible with the same swing-lift mechanism but it is essential that any biomass receival point be equipped with ramps and pits suitable for side-tip deliveries. This does not exclude rear-tip deliveries at the same facilities.

Assuming short terminal times of 20 minutes each for loading and unloading, and referring to actual contract prices from a range of transport operators, estimates have been modelled and are presented in Table 3.5.

Table 3.5 Costs of road transport of mallee biomass with side loading and unloading

Road distance one way	≤ 20 km	70 km	140 km
Radial distance from destination	15 km	50 km	100 km
Cost per green tonne	\$5	\$10	\$15

3.3.5 Discussion

A practical and economic road transport configuration will need to be developed for the mallee system. Compatibility with the infield system and unloading systems will need to be considered. Actual costs of road transport of mallee are unknown and estimates have been made based upon actual contract costs from a range of sources.

Product bulk density will need to be maximised to minimise road transport costs, but if the biomass is not agitated, it is anticipated that bulk density will be sufficient to achieve full mass loads.

The value of mallee biomass is low and it cannot sustain the high transport costs observed in wood chip transport operations.

3.4 Transport Performance

3.4.1 Losses

Sugar System

The losses from infield transport is predominantly that lost as spillage either from misalignment between the harvester and haulout, overtopping of the bin when full and spillage during transfer of product from the infield haulout to the mill transport bin (road or rail).

There is limited data on the volume of losses from these processes. However, a number of side tipping trailers do have an apron which is lowered onto the rail bin during unloading to funnel material and minimise spillage during transfer.

Mallee System

Losses will be minimal if a system without bin-to-bin tipping is implemented. Misalignment of the harvester and haulout will see some losses, and strong wind may see some loss of finer fractions of the biomass. Making the harvester and possibly the haulouts autosteer will enable operators to concentrate on the relative positions of the machinery and alignment of the harvester chute.

3.4.2 Real-time monitoring systems

Sugar System

Performance monitoring of cane haulouts is very minimal. It is limited to condition analysis of the mechanical components such as the engine and hydraulic circuitry of the power plant. For example engine hours, engine speed, oil temp and hydraulic oil level, temperature. However, the capability of performance monitoring is increasing in tractor drawn machines with the advances in tractor electronic monitoring systems.

A very small number of harvesting contractors have retrofitted haulouts with cctv cameras to improve loading at the back of the bin and for improved workplace health and safety.

Current developments are centred on the application of Precision Agriculture (PA) techniques to synchronise the operation of harvester and haulout transport vehicles (e.g. Ruxton et al. (2009)). This includes relative position monitoring using GPS-based technology. The aims are to maintain controlled traffic conditions by guiding the haulout from the harvester guidance system and synchronise the relative position of the haulout with respect to the harvester. Synchronising the relative position of the haulout with respect to the harvester can optimise billet collection by ensuring that bins are filled evenly and accurately with minimal spillage.

New South Wales Sugar Milling Cooperative has a just-in-time scheduling system based on GPS tracking for their multi-lift bin fleet.

Mallee System

A commercial transport system has not yet been developed and implemented, but the new industry has the advantage of being able to adopt sugar industry remote real time monitoring and relative position monitoring. The cane scheduling system can be adapted to the complex logistics problems anticipated in coordinating harvesting, infield and shunt transport, and container management.

3.4.3 Efficiency

Sugar System

Field efficiencies are an important measurement in the analysis of harvest transport systems.

For the infield component of transport, the target output is the quantity of material delivered to the receival point for road transport (rail/road siding). There are various harvester related (e.g. crop conditions), haulout and farm factors that influence the efficiency of the infield transport system.

The efficiency of the infield haulout is primarily dependent on:

- manoeuvrability and available space for this manoeuvring (headland width)
- row length
- haulout speed, loaded and unloaded on both field headlands and formed roads
- distance to the pad
- unloading time at the pad

In an ideal system there should be no waiting of the harvester for the haulout and no waiting of the haulout for the harvester. However, this is practically difficult to achieve in a live agricultural system with many interacting factors.

Improving farm layout by increasing row length increases the productive time for harvesters and haulouts as the time to turn at the end of each row is fixed. Maintaining wide smooth headlands and haul tracks reduces the time spent turning on headlands and provides for increased travel speed to the mill transport node, and as discussed previously (section 3.2.3 and Figure 3.8), speed is a significant factor in controlling transport cost.

Side tipper vehicles transporting burnt or green cane are reported to have an unloading time of about 1 minute (Robotham et al 2001). To unload whole-cane, side tippers take about 1.5 minutes. The side tipper capacity needs to be matched to the capacity of the road or rail bin. The use of cross conveyers has the advantage of filling road or rail transport bins of various sizes from the haulout, but the time taken per tonne for this transfer is greater than for side tippers.

Haul distance is largely outside the control of the grower and the harvesting contractor and has a significant impact on costs (section 3.2.3 and Figure 3.9) The milling companies recognise this and include a haulage allowance depending on the distance from the farm to the siding.

Mallee System

The dispersed layout of the mallee crops creates significant challenges for cost-efficient transport of biomass from the harvester to the road transport receival point.

Haulout distances of several kilometres will be commonplace unless there is some careful design of an integrated infield transport operation. Modelling the cost of biomass to the roadside landing, where road trucks are loaded, indicates that with large capacity capital intensive machines, the addition of a third and fourth haulout significantly increases costs per tonne. There will be a wide range of haulout distances experienced over periods of only hours because the harvester will travel widely across large paddocks. This will make it difficult to add extra haulout capacity opportunistically and operate different numbers of haulouts on different days, so every haulout and operator will need to be available every day.

The strategy that will be explored is to separate infield transport into short haul to the corner(s) of the paddock (to the paddock landing) and then a longer haul to the roadside landing by shunt truck or tractor. The two transport steps will allow the harvester and its attendant two haulouts to roam widely and deliver biomass to several transient paddock landings each day, and the shunt transport provides

the flexibility required to accommodate the scatter of these paddock landings. This operation will require sophisticated logistics management to ensure that both empty and full bins are where they need to be on time.

Landings, both paddock and roadside, will need to be located early in the development process to assist farmers in new planting of mallee resources. Strategic location of landings and mallee sites will help to minimise costs to the farmer.

The infield transport routes and paddock landings will not be used often enough, or for enough biomass per visit, to justify earthworks or other expensive preparation. The harvesters, haulouts and shunts will need to be appropriate for operating under paddock conditions as they are. The requirements will be determined by points along access routes where soil conditions are least favourable, not the typical conditions of the whole paddock.

Road transport in mallee systems will need to be built for purpose and side loading and unloading must be adopted to minimise truck terminal time for road trains. The other variables relating to road transport efficiency, being speed and payload, are controlled by regulation. It would be an advantage to select roadside landing positions strategically to minimise the cost of site preparation, and to space the landings so that relocation from landing to landing occurs no more than weekly.

3.5 Discussion

Infield transport is an important part of the supply chain and has been shown to be one of the major components in the delivered cost of other biomass supply chains. Similarly, road transport will have a significant impact on the delivered cost.

The transport systems will be impacted by the nature of the material to be delivered (e.g. wood chip vs. whole tree biomass with leaf material) which is impacted by biomass market. Mallee biomass will be more difficult to move, tip and transport than other biomass products such as grain, clean wood chip and cane billets.

The chipped biomass must be moved from the farm to a centralised receiving point for transfer to road transport. The chipped biomass will be thrown directly from the harvester to a following bulk bin (haulout) which will forward the material to the field edge. A shunt transport will then move the biomass to the receiving point for the road transport. Due to the cost of reclaiming heaps on the ground, it is unlikely that chipped biomass will be stored on farm.

The dispersed layout of the mallee crops creates significant challenges for cost-efficient transport of biomass from the harvester to the road transport receiving point. A lack of real crop distribution data limits the usefulness of system analysis data. Infield transport distances will vary widely over short periods of time, so transport to the roadside landings will require a two-stage process to give the operation the flexibility to cope with widely varying harvester-to-landing distances. Haulouts will need to have high capacities because they represent the smallest batch process in the supply chain.

The spatial distribution of landings will need to be matched with biomass distribution and available yield. Tradeoffs will be required between an increased number of landings and shorter infield haul distances. Haulout efficiency will be maximised if production per hectare and bulk density are maximised and haul distances to the road landing are reduced.

Similarly, mallee is spread geographically across the Western Australian wheat belt and harvesting will be a year round operation, so soil conditions will vary widely, both spatially and over time. The Mediterranean climatic conditions can see unstable soils become commonplace during winter.

Vehicles used for infield haulout will need to be suitable for off-road use and have low ground pressures. Depending on the row configuration and if low stumps are left by the harvester, rubber tracks or low floatation tyres will need to be considered.

As transport regulations vary from state to state, licensing of infield transport that travel on public roads may be required. This may involve the mallee industry working with the WA Department of Transport to define appropriate guidelines for conditional registration.

Consideration could be given to pre-processing at roadside landings, involving upgrading processes such as chip separation, oil distillation, drying and even pellet manufacture. This would improve the marketing of the biomass, by placing the emphasis of the long-haul road transport upon the movement of specific value-added products to appropriate markets. However costs and efficiencies of the several options would need to be assessed.

The need for and role of material stockpiles will need to be evaluated in terms of the supply chain management and impact on product quality. Stockpiles are a risk management strategy and can ensure continuous feedstock supply in case of interruptions (for example fire, flood, soft soils, and major mechanical breakdowns).

The grain transport trailers that are common in the wheatbelt regions do not have the volumetric capacity for biomass. The wood chip transport systems are geographically somewhat distant from mallee areas and they rely, partly for historical reasons, upon the use or rear discharge by tipping or walking floors. This requires that road trains be decoupled and reassembled for every load, which imposes extra cost upon woodchip transport compared grain transport, which can empty trucks through a grizzly screen. The mallee industry will have the opportunity to avoid this problem if it adopts side loading and unloading from the outset. If the materials handling process from the point of harvest is containerised, then side loading and unloading can be accommodated using the principles of sea container swing-lift technology.

Key considerations regarding sugar and mallee transport systems are tabulated in Appendix 1 of the document.

3.6 Recommendations

The nature of the biomass material to be delivered needs to be well defined to allow the most suitable transport system to be developed. Appropriate strategies will need to be developed for transport configurations such that the bulk density of material is not reduced.

Existing and potential haulout and road transport systems have been reviewed but conceptual designs of the alternative new systems need to be developed and proper financial analysis conducted. Comparisons of existing and potential systems need to be thorough and systematic.

A resource inventory of the existing mallee in WA is essential for proper analysis of alternative transport systems and development of the early commercial operations. It will also assist in planning and guiding future expansion of the mallee resource so as to maximise transport efficiency in the future.

4. Products, Processing and Impact on Supply Chain

Mallee, in whatever form an industry finally takes, will be a biomass production industry, and the potential for the industry to be viable will be dependent on minimising costs and maximising the value which can be extracted from the raw material harvested. From these viewpoints, the crop can be compared and contrasted with Sugarcane.

This chapter will first overview products from and processing of sugarcane, how this has evolved in response to the reduction in the relative profitability of sugar, as the primary product, over time. The range of products which can be produced from Mallee will then be discussed, the impact of large scale production on potential product value will be assessed and supply chain implications evaluated.

4.1 Product Options and Supply Chain Implications: Sugarcane.

4.1.1 Product options

Over the past three decades, paradigm shifts have occurred in sugar industries around the world. The primary product of sugar industries around the world has traditionally been crystal sugar. Electricity production was primarily for internal consumption at the sugar mill (Hobson, 2003) and environs, with export levels optimised to limit the cyclic draw on the electricity grid during start-up of high load current operations, such as sugar centrifuging.

Key issues relating to the traditional sugar mill configuration include:

- To maximise economic benefit, sucrose recovery has traditionally been maximised.
- Because of the limited economic benefit (low price, limited market) traditionally gained from electricity generation, this was limited to the amount required to operate the factory. Some optimisation of generation capacity was based on factory internal peak loads and the relative cost of imported and exported power. Factories which were not connected to grid power had to have sufficient installed generation capacity to operate in “stand-alone” mode.
- Some “value adding” of the molasses was undertaken by the production of potable or industrial alcohol either at a mill based facility or at stand-alone facilities.
- Bagasse was typically a disposal issue, so the boilers were designed to absorb the near maximum bagasse flow rates. Overall thermal efficiency of a sugar factory, including the internal process thermal requirement was typically in the order of less than 20% (Lavarack, 2004). In some countries “bagasse furnaces” were utilised in sugarmills to dispose of excess bagasse.

The most significant first challenge to this paradigm was the “Proalcohol” program in Brazil. The fundamental changes (Wright *et.al.* 2007) in this, relative to the traditional strategy included:

- Whilst the overall concept was to produce ethanol, R&D indicated that there were substantial benefits in a strategy of production of both sugar and ethanol in a combined process, as significant bio-chemical synergies were present as the two processes were integrated.

- The strategy offered lower total capital costs and operating costs per tonne of feedstock, whilst also offering a degree of flexibility to “manage” the ratio of ethanol/sucrose produced depending on market conditions.
- Products such as yeast from the fermentation process were identified as high value protein supplements for livestock industries, and other waste products, e.g. vinasse, were found to be of significant potential agricultural value.

In addition to the ethanol program, the Brazilian sugar industry has become a major supplier of electricity. The continually increasing demand for electrical energy and the complementary nature of cogeneration during the dry season and hydro during the wet season increased the overall synergies. These developments allow the Brazilian sugar industry to claim that it “produces energy for people cars and houses” (sugar, ethanol and electricity). In Brazil an active trade also exists in bagasse, as a thermal heat source both to other sugarmills for cogeneration, and to other markets such as the large citrus juice processing industry.

Sugarcane offers the potential for multiple other products which “value add” the industry. Good examples of this being the Industries in South Africa, and in particular Argentina, both of which now make high quality paper from sugarcane bagasse. The larger mills in the Argentine Industry set a new paradigm, where the value of paper products manufactured from bagasse matches or exceeds the total value of all sugar products (Gomez, 2006).

A range of other products can also be produced from bagasse. Examples from the Australian Industry (past and present) include the industrial chemical furfural (Watson L.J 2008), low density fibre-board and thermal insulation, with many other products also being manufactured by industries throughout the world.

Internationally the general move is towards increased cogeneration capacity in sugar mills to maximise the value of bagasse and other available biomass. This is being achieved by:

- Significant increases in energy efficiencies in the sugar mills, allowing for large increases in cogeneration output for the same fuel input (Lavarack 2004). This is the most common strategy being adopted in Australia, with some additional capacity being achieved by importing bagasse from nearby mills and other fuel sources such as woodchip. This strategy is currently being used by the Industry in Northern NSW (Farrell R. Pers Com).
- Supplementary fuel supply in the form of trash collected from the field in a separate post-harvest operation. In many industries around the world, coal is routinely used as a supplementary energy source. The cost of this trash relative to coal (including “green premiums” where applicable) then determines the economic value of trash, and this is then the driver of trash recovery strategies. Depending on individual circumstances this trash recovery strategy may or may not be economic.

4.1.2 Supply chain implications

Some research was undertaken in both Australia and Brazil on the potential of separating the crop components on the harvester and utilising parallel transport systems (Spinaze, 2002). The constraints on the performance of the harvester trash extraction systems, the relative variability in the ratio of the two product streams and the subsequent management of logistics of the operation have typically made this a non-viable option.

The strategy of integrated cane + trash being delivered to the sugarmill, with trash separation from the load at the sugarmill can be illustrated to give the lowest cost for trash at the mill for short transport distances, with the benefit decreasing as transport distances increase. Depending on load densities, a distance of approximately 20-25 km is considered an upper limit for this strategy. Whilst the reduction in load density and increased transport costs making the system less viable as distance increases, the

reduction in cane loss at mill based cleaning systems relative to harvester based cleaning is a major positive economic consideration (Whiteing, 2001) .

All trash recovery options (in all crops) can be argued to have agronomic impact because of the removal from the field of organic matter and plant nutrients, however other effects such as soil temperatures also significantly impact on the optimum strategies. In cold environments for sugarcane trash must be either physically removed or burned to maximise soil temperatures for reliable crop ratooning.

Figure 4.1 illustrates an operation where cane trash is being collected with forage harvesters in Brazil for cogeneration. Baling and forage harvesting are both methods whereby very significant volumes of trash are collected for this use. Sugarcane trash volumes are high relative to many other crops and the product is highly abrasive, so the equipment used has typically been developed specifically for the application, although the design concepts are based on normal forage machines.



Figure 4.1 Trash recovery for cogeneration in Brazil by baling the trash after machine harvesting.



Figure 4.2 Trash recovery from integrated trash and cane delivery in a large sugarmill in Brazil.

Figure 4.2 illustrates a trash recovery unit in Brazil for chopper harvested cane. This system is at a large sugarmill, with a daily cane crushing capacity of over 25,000 tonnes and with trash recovery being in the order of 2,500 tonnes/day. The physical and aerodynamic properties of cane trash and sugarcane billets are such that with appropriate system design high levels of trash separation can be achieved (typically > 80%) with very low cane loss (<0.5%). Trash separation on the harvester cannot reach these performance standards because of physical constraints relating both to presentation of the material to the separation system and separation system configuration. These constraints mean that

separation efficiency of harvester based systems seldom achieve 80% trash extraction and at these levels of extractor cane loss can often exceed 15% (Whiteing , 2001).

4.2 Product Options and Supply Chain Implications: Mallee

4.2.1 Product options

Whilst product options for Mallee have limited direct similarities with sugarcane, strategies of optimising the value of different plant components to maximise overall value will be critical for the successful development of a large scale mallee industry. This has been well recognised and was the basis of the integrated processing system which was developed and installed at Narrogin (Enecon, 2001).

A range of extracted and derived products can be produced from oil Mallee trees, with some being relatively specific, e.g. eucalyptus oil, to more generic products such as woodchip or activated charcoal. The experience of Integrated Wood Processing by Verve Energy in WA demonstrated that mallees can be used to produce a good quality charcoal. Pyrolysis and other processes can be used to produce derived products such as biodiesel/bio-avgas either via a process of the production and refining of a bio-oil, or more directly utilising processes of “recombining” over a specific catalyst. These processes are now being commercialised and appear to offer a major technological advance in biofuel technologies.

Mallee biomass can also be used for direct thermal applications by the use of appropriate burner/boiler technologies, or the biomass can be pelleted for a wider range of applications, including potential export to higher-value international markets. The potential market size for the different product varies significantly, as does the value of the final products, and this then drives the value of the feedstock.

More detail on these product options is provided in the section 4.3 below.

Product mix will be driven by potential mallee industry size. Section 1.3.1 discusses the potential for the production of woody biomass from mallee or similar types of crops. Under the assumed levels of adoption by farmers and using current understanding of growth rates, the southern states in Australia could potentially produce tens of millions of green tonnes of biomass a year. A highly profitable industry could conceptually favour higher levels of adoption and see expansion of the industry model into the Eastern States with an appropriate suite of crop species.

4.2.2 Supply chain impacts

The Mallee tree at harvest consists of leaf product, small/medium/large twigs, bark, and wood of varying stem diameter prior to harvest (see section 1.2.1). Typical ranges of component composition are given in Table 4.1.

Table 4.1 Typical composition of mallee at harvest size (derived from data in Peck et al, 2011)

Component	Proportions of fresh weight
Wood	20 – 40%
Twig	25 – 35%
Leaf	25 – 35%
Bark	5 – 10%

The proportions of the different components vary depending on environmental factors, tree size and spatial configuration, with a range of lesser factors also impacting on component proportions at time of harvest.

As a tree develops, leaf canopy size will develop to near maximum size within the first few years and then the growth of wood will continue while canopy size remains relatively constant and so declines as a proportion of the total biomass. Young trees therefore have higher leaf to wood ratios, with this ratio reducing as the tree ages. Tree spatial configuration also impacts on the leaf to wood ratio with the highest leaf area ratio recorded in single or double row configurations rather than multiple row configurations. This is discussed in greater detail in section 1.2.1. Both the relative proportions of leaf and stem, and total component yield will impact on harvest strategies depending on the final product being targeted.

Each of the whole tree components (wood, twigs and bark and leaf) has different chemical compositions (leaf and twig material is significantly higher in alkali metals than stem wood), and physical characteristics and consequently different potential commercial values. More significantly there are a number of different potential products which can be derived from the different tree components.

Whilst load densities in the order of 350-400 kg/m³ have been recorded (Bartle, J, Pers Com, 2011) a varying mix of the components in a woodchip blend (leaf, twigs, bark and woodchip), along with component size, can potentially impact on transport density and subsequently transport cost. Potentially also, moisture content of leaf components may also impact on the compliance of smaller components and subsequently dry packing density of the product. This will be amplified with respect to fresh weight density. The inherent variability in product density will potentially therefore impact on transport cost and subsequently on the distance the product can economically be taken for processing.

Leaf and twigs in the ex-harvester product present other issues. Whilst hardwood chip has good storage characteristics, the leaf material is significantly more prone to degradation, and this will impact on potential value. If oil extraction is to be undertaken this must occur within days of harvest.

Depending on the intended uses of the product being harvested and the transport distances involved, separation of the product into components at or soon after the harvesting process could offer significant advantage. Nominally, strategies which could be appropriate include:

- Separate the product on the harvester, with the components of lower industrial value being rejected and deposited back into the field. This is similar to grain harvesting where all material other than grain is rejected or sugarcane, where the aim is to separate the trash and return it to the field.
- Separate the products on the harvester, but have parallel transport systems to forward the material to different processing nodes. Figure 4.3 illustrates a system being trialed at a Brazilian sugar mill, where the trash separated by the harvester extractor system is transported to the mill in a separate transport system instead of being left in the field. Figure 4.4 shows an option which is available for tree choppers and forage harvesters to remove a proportion of the leaf and lighter material, however conceptually this could evolve into strategies to simultaneously take two product streams from the field.
- Transfer the whole tree product to a local processing node with equipment which is optimised for the task, and undertake a separation process/ initial processing at the node. Value added product could then be forwarded via optimised transport systems to markets further afield.



Figure 4.3 System in Brazil for separating trash on the harvester and transporting it separately to the mill.



Figure 4.4 Attachments are available for choppers and forage harvesters to remove a proportion of the leaf and lighter material.

Aggressive strategies to remove leaf (and twig) by the incorporation of separation systems on the harvester could be anticipated to be able to reduce leaf levels and thus improve transport efficiency (by transporting only the most valuable fraction of the biomass), however high levels of leaf extraction could be anticipated to result in correspondingly high levels of loss of woodchip. Where the leaf material is considered to be of zero or negative value, this may be an appropriate strategy, despite the losses, with additional “cleanup” being undertaken at point of delivery.

The limitation on separation performance will clearly apply also to any strategy targeting separation of harvested material into different product streams on the harvester. High levels of cross contamination will not be avoidable. Whilst this strategy is interesting in concept, an additional constraint to this strategy is the logistic issues associated with the dual transport systems.

At nodal processing points, the degree of separation of delivered material into product classes (leaf, twigs, bark and woodchip) will be dependent on the technology used, with high levels of efficiency in product partitioning incorporating multi-phase separation, probably including size grading, a degree of “gravity” separation and pneumatic separation. This equipment would be anticipated to be either fixed or re-locatable, but not mobile for “infield” use.

Case by case evaluation of the economics of different strategies will be required, with factors such as eventual Industry size and distribution having a significant impact on future development paths.

4.3 Mallee Products and Conversion Technologies

A range of products can potentially be derived from mallee trees, with three main processes being utilised:

- *Extraction of oils.* Whilst a number of processes can be utilised for the extraction of oils from biomass, with mallee the main source of oils is in the leaf material and steam extraction is considered the most appropriate technology;
- *Thermal conversion.* Thermal conversion ranges from combustion, where the aim is to maximise heat recovery for process heat or electricity generation, to a range of processes where the combustion process is controlled and targeted products are produced. The process can be manipulated to maximise output of a range of products from charcoal to combustible gasses. Gasses can then be further converted into liquid fuels (e.g “bio-crude”). Heat is also liberated. The process is well described by El Bassam (2010). Figure 4.5a illustrates the mass balance of the process of gasification and bio-oil production from a biomass crop, with the basis being 1000 kg of feedstock dry-material prior to the conversion process. Figure 4.5b gives the energy balance for material at 25% moisture content initial condition. The actual conversion efficiencies to the nominated end products can be manipulated by the temperature of the process, with higher temperatures favouring higher production of gasses and oil, and lower temperatures favouring the production of char.
- *Physical conversion.* Physical conversion of biomass is in the context of a bioenergy crop is primarily by processes such as briquetting or pelleting. This strategy is primarily used to “standardise” the product and maximise density for transport.

Whilst the oil extraction process and physical conversion require the addition of energy, thermal conversion is essentially exothermic. Whilst thermal conversion technology has been used on a large scale for many years (charcoal production, Fischer Tropsch for liquid fuel production and “producer gas” for stationary applications) technology is developing rapidly.

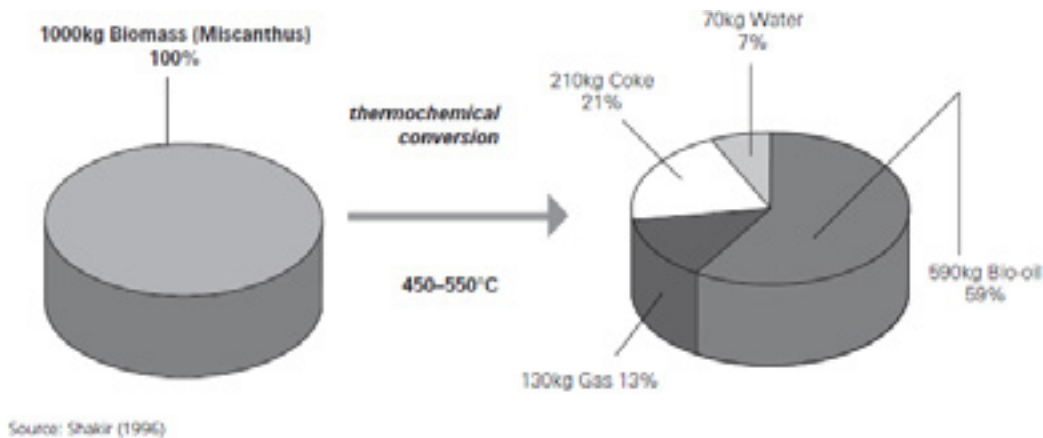
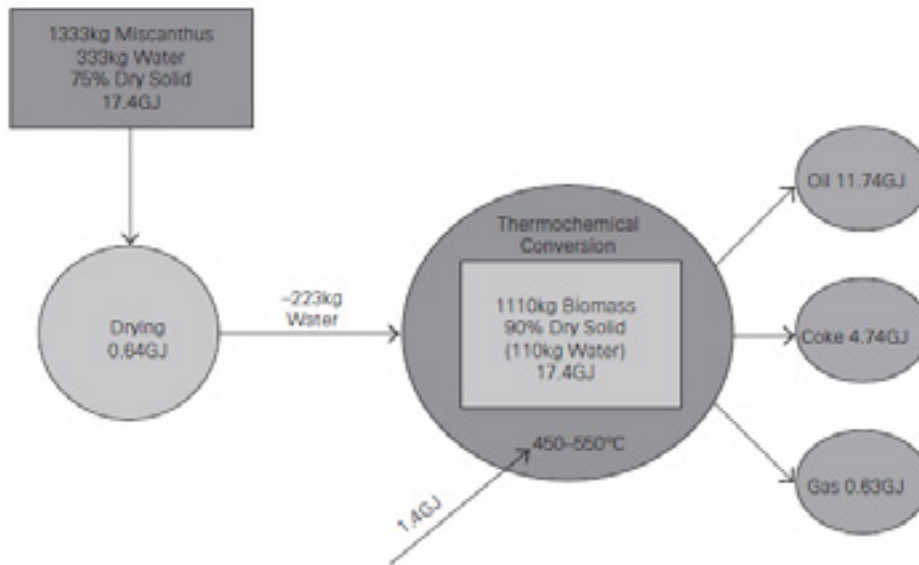

Figure 4.5(a) Mass balance of biomass conversion using fast pyrolysis.(El Bassam 2010)



Source: Shakir (1996)

Figure 4.5(b) Energy balance of conversion of biomass using fast pyrolysis.

4.4 Mallee Products, Markets and Value

Whilst a wide range of products can be derived from Oil Mallee trees, the market availability for the products will be the most significant issue. Key issues to be determined relating to an initial assessment of these products includes:

- Current Australian or if relevant worldwide production of the product;
- Estimated current ex-factory price for the product;
- Potential production from a full scale potential Western Australian or Australian industry;
- An estimate of the ex-factory value of the price of the product if the nominated potential production was achieved.

Current Production: Australian or Worldwide production of the range of products is estimated as a precursor to what impact a significant Industry would have on the domestic and international supply chains.

Current Price: The estimated current ex-factory price for the product based on a limited search and known data. For example, the current price paid for Mallee Oil as a boutique product is in the order of \$10/kg, however Australian production is 150t/year and total world production is approximately 4,000t/year. The price of other potential products can be derived from known data.

Potential for Increased Production: The adoption of Mallee in the WA wheat belt as portrayed in section 1.3.1 would result in about 8 million tonnes fresh weight of whole tree product per year. This is a significant resource, although of modest value against the typical annual West Australian wheat harvest of over 4M tonnes. This could potentially produce about 80,000 tonnes of oil annually in Western Australia alone.

Table 4.2 Assessment of current value and annual production and potential production and possible impact on product value.

Product	Current Market Price (Estimated ex-factory)	Current Annual Production	Potential Production after conversion efficiencies.	Potential price at large scale production.
Mallee Oil	\$10/ kg oil current price for small producers for “Boutique” market.	4,000 t/year worldwide 150t/year Australia	85,000t/year from leaf product.	\$2.00/kg, industrial solvent/ industrial feedstock
Activated Charcoal	\$3000/t product for high value uses such as water purification and gold processing.	Not known	350,000 t/year if all product converted.	\$300/t (a 50% premium on metallurgical charcoal.)
Metallurgical Charcoal	Not known but plant at Bunbury utilising forest log waste.	Current limited local production “in-house”.	1.75M t of various grades from woodchip. logs.	\$200/t nominal commodity price, but could be a premium for “lump” product.
Bio-oil (Industrial Feedstock)	Refinery feedstock: 60% of diesel equivalent thermal value.	Not currently produced.	2,000ML/year (from total biomass).	60% of diesel equivalent thermal value
Diesel/Avgas	Direct consumption through oil distribution system.	Not currently produced.	2,000ML/year (from total biomass).	80% of diesel equivalent thermal value.
Bio-char	Currently in excess of \$400/t as fertiliser additive.	Limited current production from other sources.	1.75 M t/year (from total biomass).	\$ 85/ \$185 per tonne on \$23/\$50 carbon tax as sequestration value.
Process heat for local abattoirs and similar.	\$19.8 /GJ, LPG \$23.80/GJ Diesel \$41.67/GJ Electricity	Limited local usage in “low tech” applications.	106,000 TJ. (from total biomass).	Limited market. (2-10 MW thermal facilities, 0.6 - 3 t/hr)
Electricity Grid input	Grid \$.05 /kW hr nominal, \$.08 / kW hr with REC’s.	Limited co-firing.	7,400GW hr/ year.	Limited sensitivity but large market.
Local Electricity	Displacement of local Grid power @ \$.20/kWhr	Not currently done.	5,900 GW hr/ year.	Limited market and high price sensitivity.
Local Electricity	Remote (Diesel displacement) @ \$.35 /kWhr	Not currently done.	5,900 GW hr/ year.	Limited market and limited price sensitivity.

Impact of Increased Production: The impact of potential production on the ex-factory price, assuming maximum potential production was diverted into that product, must be assessed. The actual impact of increasing the volume of a particular product on the market will be dependent on the rate of increase in production, and high value products may help the establishment of the Industry. Again, in the example of Mallee oil, the industrial price which would be achieved under the scenario of large scale production is believed to be close to \$2.00/kg (Enecon, 2001), but other industrial markets are being explored, such as the use of cineole as a precursor for the manufacture of plastics (Bartle and Abadi, 2010). Table 4.2 presents a summary of some potential products, and an assessment of the parameters above.

Table 4.2 indicates that a large scale Mallee Industry would potentially very significantly impact on the current value of a number of products. For example, current producers of eucalyptus oil would see a dramatic reduction in the value of their product if even a small percentage of the potential production of mallee oil entered the market they are currently targeting. As part of an industrial process however,

even at the anticipated dramatically reduced oil value, oil extraction could be an important component of overall economics of a larger industry.

Other high value markets are generally low product volume, such as thermal energy displacement in local industries such as feedmills and abattoirs, and the even smaller potential market as local electricity production utilising rapidly developing technologies such as Organic Rankine Cycle systems to convert low grade thermal energy to electricity to displace diesel electricity generation units.

Potential higher value uses without volume limitations include conversion utilising gasification or pyrolysis to liquid fuels. Current technology converts the syngas and other gaseous products to heavy oil, which can be utilised directly as a furnace fuel, or refined into more traditional products. More recent development has been towards “reforming” the gas products over a catalyst to produce synthetic diesel or avgas, and limited by-products. Whilst substantial research and development is being undertaken into this technology and results are exciting, it is not yet commercialised. Indications are that overall conversion efficiency is in the order of 55%, although higher efficiencies are potentially achievable (Holmgren pers com, 2011). Charcoal and combustible gasses are additional products.

Table 4.3- 4.9 analyses each potential product, including anticipated industrial product value, and extraction/conversion costs to derive values for the crop component being utilised as feedstock for a process.

4.4.1 Mallee oil

Available data indicates that average oil recovery from steam extraction is approximately 10 kg/green tonne from whole trees or 18 kg/green tonne from leaf and twig components. This is nominally consistent with minimal extractable oil in the wood component of the tree, and varies according to leaf age, season and other agronomic parameters. The energy required for steam extraction of the oil is typically 10 kg of saturated steam/kg of oil, however allowance must also be made for heating of the biomass prior to extraction commencing.

The extraction process results in a leeching of much of the water-soluble alkali products from the leaf. The resulting liquor has some potential value as a fertiliser because of this, however energy would be required to concentrate it to reduce the product volume for cost efficient transport. More significantly, research indicates that the oil extraction process can actually increase the value of these components for some downstream uses such as metallurgical charcoal. The process would also be anticipated to increase the value of these products for various thermal uses because of the reduction in specific alkalis.

After the extraction process, the leaf and twig material would have to be dried before further use. The use of thermal drying utilising a proportion of the material after oil extraction would consume in the order of 35% of the product. Alternative strategies include solar drying, by spreading the product in thin layers over a large area. This would involve a number of operations and cost to spread, turn and collect the material.

Because of the extraction of the oil component, an alternative boutique use of leaf and twig could be as feedstock for compost however additional agricultural waste would probably be required to achieve correct component ratios. Some synergies may exist with abattoirs with respect to the production of high value compost however the concentrations of heavy metals in the leaf material and or extracted liquid could be an issue.

Table 4.3 presents data on the production of mallee oil. The extraction costs are nominal based on the energy requirement for the extraction process on gas costs only. In an industrial process, energy would be supplied from combustion of used product, with the nominal saving being absorbed by fixed and variable costs associated with the process.

Table 4.3 Value of feedstock components for Mallee Oil for boutique and industrial use

Oil Value (\$/kg)	\$10		\$2	
	leaf & twig	whole tree	leaf & twig	whole tree
Extraction cost (\$/kg)	\$ 0.84	\$ 1.08	\$ 0.84	\$ 1.08
Product Value (\$/kg)	\$9.16	\$8.92	\$1.16	\$0.92
Product yield (kg/gt)	18.0	10.5	18.0	10.5
Value/gt freshweight at factory	\$ 164.81	\$ 93.69	\$ 20.81	\$ 9.69
Residual product	Wet leaf & twig + separated woodchip	Wet leaf & twig & woodchip	Wet leaf & twig + separated woodchip	Wet leaf & twig & woodchip
Residual Product Value	* 100% of woodchip * 65% of leaf & twig	* 90% of woodchip * 65% of leaf & twig	* 100% of woodchip * 65% of leaf & twig	* 90% of woodchip * 65% of leaf & twig

Table 4.3 indicates that:

- For the boutique market with an oil price of \$10/kg ex-factory, feedstock value at the factory is in the order of \$165/green tonne for leaf and twig components of the tree if pre-separated, or \$94/green tonne for the whole tree if the entire harvested product is processed.
- The value of leaf and twig based on industrial oil prices are \$21/green tonne for leaf and twig if separated prior to the process or \$10/green tonne if the whole tree is run through the extraction process. The increased thermal requirement to process the whole tree instead of leaf (and twigs) only equates to approximately \$0.24/kg of oil. Whilst this is barely significant in the case of boutique oil, it is highly significant in the economics of industrial oil.

These costs indicate that oil extraction for industrial use is not a viable “stand-alone” use of harvested malle in a large scale industry; however oil extraction from the separated leaf and twig material can potentially give an additional income stream. After oil extraction has been undertaken:

- If pre-separated, the full value of the woodchip would still be available, however if the woodchip was subjected to steam extraction, some degradation would have occurred, along with an increase in moisture content;
- The reduced alkali levels in leaf and twig material can be anticipated to reduce potential problems associated with combustion of these products, thus potentially increasing their value;
- Work at Curtin University (<http://asdi.curtin.edu.au/csrp/projects/4c2.html>) indicates that after oil extraction, leaf and twig material actually convert into a higher value metallurgical charcoal than wood.
- To capitalise on this value, it would be necessary to efficiently re-dry and process the material. The energy required to achieve this would be equivalent to combusting approximately 35% of the material.

4.4.2 Activated charcoal

Activated charcoal is used for water purification and some minerals processing. It is a high value product, however the market is limited.

Typically activated charcoal production equates to approximately 4% of initial feedstock mass. To meet various technical requirements the feedstock must be “clean” woodchip. The process is highly exothermic.

A “process cost” of \$0.50/kg of final product is assumed for capital and operating costs of the facility required to perform the process, however significant energy is released in the process, with this potentially being captured as thermal energy or chemical energy (syn gas or bio-oil). Table 4.4 indicates that the value of feedstock for the production of activated charcoal would then be in the order

of \$100/green tonne for clean woodchip or \$41/green tonne for chopped whole tree product, which would have to be separated into components prior to use.

Table 4.4 Value of feedstock components for activated charcoal.

Product Value (\$/kg)	\$ 3.00
Component Used	Woodchip
Extraction cost (\$/kg)	\$ 0.50
Product Value (\$/kg)	\$2.50
Product yield (% of freshweight)	4.1%
Value/t freshweight separated woodchip	\$ 102.60
Value/t freshweight whole tree	\$ 41.04
Residual and co-products	Heat syngas and bio-crude.
Co-Product value	App 80% of initial energy content as heat and combustables/feedstock.

The production of activated charcoal results in significant heat production and production of syngas and bio-crude, with a significant proportion of the energy in the initial feedstock being liberated in these components. After the production of activated charcoal, significant further value can be extracted from the feedstock.

4.4.3 Metallurgical charcoal

Metallurgical Charcoal is used in a number of processes and is formed by stopping the reduction process earlier than for activated charcoal, which is actually produced in a two stage process.

The recovered mass of metallurgical charcoal is typically around 21% of woodchip freshweight (at 42% MC), and leaf and twig would be considered to be of limited value, however as noted above the research at Curtin University indicates that extracted leaf and twig material has enhanced value as a feedstock for metallurgical charcoal because of the properties of the charcoal produced.

Table 4.5 indicates that at typical industrial prices for metallurgical charcoal of around \$200/tonne. It is assumed that the process cost will be in the order of \$25/tonne final product. Whilst woodchip is the assumed feedstock, some price premium could possibly also be achieved by the production of block charcoal.

Table 4.5 Value of feedstock components for Metallurgical Charcoal

Product Value (\$/t)	\$198 high volume sales
Component Used	Woodchip / log and “extracted” leaf and twig
Extraction cost (\$/t)	\$50/t charcoal
Product Value (\$/t)	\$148.00
Product yield (% of freshweight)	20-30%
Value/gt freshweight separated woodchip/log	\$ 36.00-\$54.00
Value/gt freshweight whole tree including extracted leaf	\$ 36.00-\$54.00
Residual and co-products	Heat & syngas/ bio-crude.
Co-Product value	App 60% of initial energy content as heat and combustables/feedstock.

As with the production of activated charcoal, the production of metallurgical charcoal results in significant heat production and production of syngas. Whilst a greater proportion of the initial energy is lost to the charcoal product stream, significant energy is still available for downstream use as heat or for the production of bio-crude.

4.3.4 Bio-Char

Bio-char is a relatively newly commercialised product, with a range of uses. Bio-char has high value use as a fertiliser component, whilst a lower value use is as a soil physical ameliorant. Biochar can also be used as a vehicle for carbon sequestration, and a value can be derived based on the value assumed for a carbon tax of nominally \$50/tonne CO₂.

As with other thermal conversion processes, the recovery of bio-char is dependent on the time and temperature in the reactor, with low temperatures preferred for maximising char recoveries, with overall recoveries of approximately 30% (char : freshweight) being reported as typical. The process consumes the syngases and bio-crude, however the combustion of these products maximises the exothermic nature of the reaction.

These lower temperature processes reduce the potential for efficient use of the liberated heat in “steam cycle” conversion processes, however the exhaust heat temperature matches some processes such as Organic Rankine Cycle units for electricity production.

Bio-Char as an industrial feedstock for the fertiliser industry has a very significantly higher value than for its use for carbon sequestration, however the value as an industrial product will be dependent on supply. The current price is in the order of \$500/tonne (J Joyce, Pers Com, 2011). For this application, pre-extraction of oil from leaf material would reduce its value because of the value of alkalis and other inorganics in the leaf material when used as a fertiliser component.

Syngas and heat are by-products of the production of bio-char production, and these can be used directly in downstream processes, e.g thermal applications.

Table 4.6 Value of feedstock components for Bio-Char for various uses.

Bio Char	Fertiliser Additive	CO ₂ Sequestration
Product Value (\$/t)	\$ 500	\$50/t CO ₂
Component Used	whole tree	whole tree
Extraction cost (\$/t)	\$25	\$25
Nett Product Value (\$/t)	\$475.00	\$ 158.33
Product yield (%) freshweight	29.0%	29%
Value/gt freshweight whole tree	\$ 137.75	\$ 45.92
Residual/co-product	Heat and syngas/bio-crude	
Co-Product value	App 60% of initial energy content as heat and combustables/feedstock.	

The value of processing Mallee to produce bio-char for sequestration must be further reduced by the cost of delivering the product back to the field and spreading it, and as such this is not likely to be a primary use for oil mallee trees.

4.4.5 Bio-oil products

Direct conversion technologies whereby biomass is pyrolysed at high temperature, with the aim of maximising the conversion of all carbon in the product (and minimising charcoal production) and the syngas recombined to a higher value product are developing rapidly. Whilst initially a heavy bio-crude oil was produced which required further refining, current technology is moving towards direct production of diesel and avgas substitutes by re-combination over specific catalysts (Darmastader, E Pers com, 2011).

Available information is that yields of product such as syn-diesel are in the order of 55 US gallons/US ton of dry ash free fibre (Darmastader per som, 2011). This equates to approximately 134 l/tonne

freshweight of Mallee. Excess heat is produced as a by-product, and the process can be manipulated to produce some char, at the expense of reduced yield. “Production modules” for this technology are currently in the order of 120,000 tonne fibre/year. Table 4.7 indicates that, assuming conversion efficiency of 134l/tonne DAF (55 US gal/US ton), and a processing cost of approximately \$.20/l, the feedstock value at the factory gate is in the order of \$93/tonne fresh weight. The impact of pre-extraction of mallee oil would be a small reduction in recovery of this product.

Table 4.7 Value of feedstock components for the manufacture of Synthetic Diesel.

Product Value (\$/l)	\$0.90
Component Used	whole tree
Extraction cost (\$/l)	\$0.20
Nett Product Value (\$/l)	\$0.70
Product yield (l/t) freshweight whole tree	134
Value (\$/t) freshweight whole tree	\$ 93.50
Residual/co-product	Limited heat & char
Co-Product value	Negligible

As the aim of the pyrolysis operation would be to maximise conversion efficiency, negligible co-products would be produced. The production of synthetic diesel and similar products would be volume insensitive and with a long term positive price trend. Additional income from the excess thermal output would be limited.

4.4.6 Local thermal

The use of chipped oil Mallee as a source of thermal energy is of interest to local users such as abattoirs and stockfeed processors, as a potential substitute for diesel or LPG. In the South West of Western Australia a number of facilities utilise diesel or LPG, with the thermal outputs of the systems typically being between 2MW and 10MW. The plants typically also have a significant electrical load.

Combustion of Mallee can potentially be a cost effective option, given the probable continuing increase in fossil energy prices. Energy recovery efficiency will be significantly lower than for units currently fired with LPG and somewhat lower than current diesel fired units. Some additional capital requirement and management and control will be required. The market is of limited total capacity and highly localised.

Potentially, steam extraction of mallee oil could be undertaken in conjunction with a thermal facility. Similarly, with appropriate equipment selection, potential also exists to make other co-products such as bio-char.

Table 4.8 Value of Mallee as a feedstock for local small-scale thermal applications

Thermal	LPG	Diesel
Product Value (\$/GJ)	\$19.15	\$23.81
Component Used	whole tree	whole tree
Relative Efficiency	75%	85%
Nett Product Value (\$/GJ)	\$14.36	\$20.24
Energy Content GJ/t freshweight whole tree	10.00	10.00
Value/t freshweight whole tree	\$ 143.63	\$ 202.39
Residual/co-product	Mallee Oil / Limited Bio Char	
Co-Product value.	Extracted Mallee Oil, limited Bio-Char	

Table 4.8 indicates that Mallee is more competitive against diesel fired installations than against LPG installations, and that this is a potentially good market for small scale production. A 10MW thermal operation (medium abattoir) with 60% efficiency biomass boilers and operating for 24 hrs/day for 220 days/year would consume 25,000 green tonnes biomass/year.

4.4.7 Electricity

Electricity can be generated from biomass via three potential strategies:

- Co-firing biomass in high efficiency coal fired power stations.
- Gasification and use in internal combustion engines/turbines with heat recovery.
- Combust and utilise the heat in high efficiency ORC system.

The co-firing of woodchip into coal fired power stations gives energy recovery efficiencies similar to that achieved with coal, however the increased price of electricity associated with REC's can be claimed giving an effective price of approximately \$80/MWhr.

Higher energy recovery efficiencies can potentially be achieved with gasification, and use of the gas in internal combustion engines with heat recovery. Claimed conversion efficiencies are over 50% however this technology has not is not yet been commercialised on a large scale.

The combustion of the product in conjunction with low pressure steam boilers and mini-turbines, or Organic Rankine Cycle systems, are suitable for installations in the order of 0.5 to 2MW. Typical overall efficiencies are in the order of 20-25% for optimised ORC systems and 10% for steam cycle systems (Joyce, J. Pers Com).

Table 4.9 presents an estimation of the value of chipped mallee as a fuel for electricity generation, under three scenarios:

- as a product for co-fuelling in large coal fired power stations ,
- Local substitution for grid power in areas with limited grid supply and;
- In a stand-alone facility to replace diesel gensets.

In the first and last example, transport of the product to the end user would be a significant consideration, as coal fired power stations are not generally sited near potential Mallee production areas and large diesel gensets tend to be located near remote mining operations. In the second example, the local power generation is displacing local grid supply, but nominally at full retail cost. For the purposes for analysis a value of \$200/MWhr is assumed.

Table 4.9 Value of Mallee woodchip for electricity generation.

Electricity	Co-fire with Coal	Local ORC Grid Displacement	Local ORC Diesel Displacement
Product Value (\$/MWhr)	\$ 80	\$200	\$ 350
Process cost (%)	10%	20%	20%
Nett product Value	\$72	\$160	\$280
Component Used	whole tree	whole tree	whole tree
Energy Recovery Efficiency	30%	20%	20%
Energy Recovery GJ/t freshweight whole tree	3.04	2.02	2.02
Value/t freshweight whole tree	\$ 60.80	\$90.00	\$ 157.52
Residual/co-product	Mallee Oil / Bio-Char / Process heat		
Co-Product value.	Extracted Mallee Oil, limited Bio-Char, process heat		

4.4.8 Summary of Crop Component Value

The above analysis indicates that products from Mallee can nominally be categorised into three categories:

- Products with high value but limited potential market;
- Products which have co-products with significant potential combined value, and;
- Products which are consumed in the nominated process, and have a single product value.

Table 4.10 presents a summary of the value of recoverable/derivable components from the range of different potential products, and an indication of the potential residual value in co-products.

Products with high value but limited market include:

- Boutique oil production, and;
- Activated charcoal

Both these products also have significant potential for additional revenue from co-products. The oil extraction process enhances the value of leaf and twig material for other uses, whereas the production of activated charcoal results in the liberation of significant quantities of combustible gas and heat, both which can be used in downstream processes.

Local thermal and electricity supply in remote areas is potentially a high value product, however there is probably limited scope for co-products except the potential production of mallee oil.

The “high value” products are potentially most useful in the “development” phase of an industry, however they will not be a significant component of an industry of the size envisaged.

An example of a high value utilisation strategy for a limited industry size could include:

- Harvest and post-harvest component separation. It is assumed that the leaf and twig material would be separated at the processing site.
- Oil extraction from the leaf material, with a moderately low value of \$4/kg for the extracted oil.
- Solar drying of the leaf and twig material as a thin layer.
- Utilisation of the woodchip and leaf material in a biomass furnace of appropriate design for process heat and electricity generation.

The nominal value of the components could be:

- Oil from leaf and twig @ \$4/kg: This gives a value to the separated leaf and twig material of approximately \$57/t freshweight, or approximately \$34/t freshweight of the total material harvested (leaf & twig : 60% of weight).
- Electricity, local ORC at grid displacement cost of \$200/MW hr, giving a whole tree freshweight value of \$90/ton, and assuming that the leaf component is being used and its moisture content has been reduced to no greater than fresh moisture content, and;
- Local thermal (hot water & steam) for process applications: assuming only 40% of the energy in the waste heat streams is captured utilised (approximately 30% overall heat recovery and utilisation), and that this heat displaces LPG, the value of the total product will be \$60/t on a freshweight basis.

The tree value for this scenario would be in the order of \$185/t. While this may be possible in a small scale industry, this would not be considered a potential scenario for a larger industry.

The cost pressures on an industry which attempts to expand will be significant because of reducing product values, however strategic combination of components, along with reductions in cost will clearly be the only viable strategy.

A large scale operation in the future may involve:

- Harvest and post-harvest separation of components at a nearby nodal point.
- Oil extraction from the leaf, drying and densification of the leaf.
- Transport of densified leaf and woodchip material separately to centralised facilities where processes such as the metallurgical charcoal and bio-crude of synthesised diesel are produced.

Significantly, initial indications are that the technologies being developed for the production of synthesised diesel would appear to be suited for moderate size facilities which could be decentralised. If not, the model being investigated by the Sugar industry involves the production of bio-crude and transport this higher value product to major centralised facilities (Hobson, pers com, 2011).

This scenario could result in gross product values in the order of:

- Oil from leaf @ \$2/kg \$12/t freshweight (FW) on whole tree basis.
- Metallurgical Charcoal \$45/t, whole tree FW with solar drying of leaf, and;
- Synthesised Diesel \$46/t FW assuming 50% recovery of chemical energy in gas stream from the charcoal process.

This would give a total feedstock value in the order of \$103/t, with reduced oil recovery efficiency because of the production of metallurgical charcoal.

Alternatively the local recovery of oil from leaf and twig material, followed by the utilisation of all feedstock for synthesised oil production,

- Oil from leaf @ \$2/kg \$12/t freshweight on whole tree basis.
- Synthesised Diesel \$94/t fresh weight of whole tree biomass.

This scenario also indicates tree freshweight values in the order of \$106/tonne, freshweight, this will however involve transport to major regional processing centres, and associated transport costs. A pre-requisite requirement would be a reduction in harvesting costs relative to current anticipated values.

Whilst the value of the oil extracted from the leaf material is low, considerations include:

- The leaf and twig material has been processed through the harvester, and the only additional cost is the transport cost to a nodal point.
- After processing (leaf separation and oil extraction) at a nodal point, the value of the leaf material is increased, and the product can be densified, e.g baled.

- Separation of the leaf material on the harvester would result in a significant loss of woodchip product in the field, and this strategy is unlikely to give the highest overall returns.

The use of woodchip as a co-fuel in coal fired power stations represents a single use, with relatively low value. It is difficult to envisage this being a major market for mallee, because of the inherent cost associated with transport of the product to site.

Table 4.10 Summary of value of recoverable/deliverable components.

Product:	Product Value		Tree Component	Extraction Cost		Product Value		Product yield/ t Freshweight (FW)		Value/t FW	Co-product Value
Mallee Oil	\$10.00	/kg	Leaf & Twig	\$0.84	/kg	\$ 9.16	/kg	18	kg/t	\$165	Woodchip plus wet extracted leaf & twig
	\$2.00	/kg	Leaf & Twig	\$0.84	/kg	\$ 1.16	/kg	18	kg/t	\$ 21	
Activated Charcoal	\$3.00	/kg	woodchip	\$0.50	/kg	\$ 2.50	/kg	41	kg/t	\$103	App 80% of initial energy as heat + syngas
Metalurgical Charcoal	\$198	/t	whole tree	\$25.00	/t	\$173.00	/t	210	kg/t	\$ 36-\$54	App 50% of initial energy as heat + syngas
Bio Char (Industrial)	\$500	/t	whole tree	\$25	/t	\$475.00	/t	290	kg/t	\$138	App 60% of initial energy as heat + syngas
Bio Char (Sequestration)	\$50	/tCO ₂	whole tree	\$25	/t	158.33	/t	290	kg/t	\$46	App 60% of initial energy as heat + syngas
Synthetic Diesel	\$0.90	\$/l	whole tree	\$0.20	/l	\$ 0.70	/l	134	l/t	\$94	Negligible
Local Thermal (LPG)	\$19.15	\$/GJ	whole tree	Relative Efficiency	75%	\$ 14.36		10.00	GJ/t	\$144	Negligible
Local Thermal (Diesel)	\$23.81	\$/GJ	whole tree	Relative Efficiency	85%	\$ 20.24		10.00	GJ/t	\$202	
Grid Electricity	\$80	MW hr	whole tree			\$72	/MW hr	3.04	GJ/t	\$61	Negligible
Local Grid	\$200	MW hr	Whole tree			\$200	/MW hr	2.02	GJ/t	\$90	
Local Electricity	\$350	MW hr	whole tree			\$280	/MW hr	2.02	GJ/t	\$158	

The strategy required to maximise overall industry value is to maximise both value and use of tree components, within the constraints of transport costs and other associated costs.

4.4.9 Strategies to Maximise Product Value

Analysis of the information in Section 4.4.8 indicates that maximising Industry value may require product separation partial processing (e.g. oil extraction from leaf) and transport of product. These constraints must “mesh” with the requirements of minimising harvesting costs and transport costs. Storage life of components of harvested trees both individually and as a composite will also be a significant issue.

Whilst definitive information on the typical range in bulk density of chipped oil mallee is not readily available, the chipped “whole tree” product has two constraints:

- The bulk density of the leaf and twig components may potentially result in lower payloads than that achieved with clean woodchip, although a number of factors will impact on this. This may impact on load density and will impact on the transport costs of chip versus leaf/twig residue material, and;
- Whilst clean woodchip has a significant storage life, the leaf material component in harvested whole trees will deteriorate. The oil in the leaf material has a relatively short life, of less than a week and under some circumstances the product can spontaneously combust.

With the proposed harvesting strategies of chipping the whole trees, this significantly impacts on the strategies available for the Industry to manage the supply chain for the product.

Key issues are:

- Apart from local thermal and electricity, most higher value uses of Mallee will require significant transport and some storage.
- The leaf and twig material are of lower density and deteriorate more rapidly than chipped wood material. They are of some potential value for oil extraction.
- After oil extraction, this material is of similar value to woodchip for many potential uses.
- A high level of extraction of leaf material is desirable to maximise the value of woodchip for a number of potential uses.
- Using current or envisaged technology, the product off the harvester would not meet envisaged standards for many applications because of the mix of components.

The strategy indicated in Section 4.4.8 for an expanding industry is:

- Harvest the mallee trees utilising short haul transport concepts such as are used in the sugar industry to transport the product 20-30 km from farms to nodal processing sites.
- The nodal processing sites would have the appropriate re-locatable equipment to separate leaf, twig and bark material from the chipped wood. This would be undertaken with a combination of high performance pneumatic separation, gravity screens and component sizing.
- The woodchip would be transported directly via rail or road to appropriate processing facilities such as synthetic diesel production.
- The mallee oil would be extracted utilising relatively low technology steam extraction at the nodal processing site. The extracted leaf could be sun-dried utilising low tech strategies such as shallow bed drying.

The dried leaf could then be utilised for a number of potential uses, including baling for lower cost of transport to higher value potential uses and local use for local thermal or electricity production.

4.5 Summary and Recommendations

The development of a viable industry based on oil mallee cannot happen overnight, however analysis of the potential for downstream products to support a large scale industry is promising.

The industry cannot, however, develop on the back of current products such as the boutique oil industry. The magnitude of the potential supply will overwhelm the current market. Extracted oil is seen as an important potential product, but as an industrial product, and as a strategy to “value add” the leaf material. At the projected prices, it is not a viable product in its own right.

Similarly, a number of local options exist which can offer very attractive markets for limited production quantities. Such markets include local thermal for abattoirs and feedmilling, and local electricity. The former displaces LPG and diesel as heat sources, and the latter displaces local diesel fuelled systems, or perhaps when used on-site as an alternative to retail electricity purchased off the grid. Both these will remain as markets, but are limited in size. Significantly, technologies such as “combined heat and power” and the technology development to incorporate harvested mallee as a feedstock will be important pre-cursors for the technologies for the larger scale industry.

As the Industry expands, most significant potential market will probably involve emerging technologies such as liquid fuels via pyrolysis. On the basis of current information, this market is seen as offering good returns, with the technology being appropriate for major regional centres, thus managing transport costs. Initial process and oil extraction would be undertaken at nodal points, with value added product forwarded to the major centres.

Whilst co-firing of coal fired power stations with mallee is potentially a very large market which could nominally consume the entire projected annual harvest, the location of coal fired power stations relative to mallee production areas means that co-firing will not be a major market for the bulk of the projected industry, because of transport costs.

Products such as metallurgical charcoal and bio-char are potentially significant products, but of lower value, and unlikely to drive major industry expansion unless costs of harvest and transport were significantly reduced relative to projected levels.

The development of a long term viable project can be driven by actively targeting small but potentially highly profitable niche markets in the short term, and supporting these to further develop the technology envisaged for a larger scale industry.

Apart from continuing development of harvesting technology, the components in a model of a full scale industry must be further developed. This will involve further analysis of potential product streams and the opportunities for maximising the synergies from the production of different products.

Whilst further development of the overall industry model is required, a number of enabling technologies will almost certainly be required to be developed and optimised. It is probable that the technologies will include:

- Efficient separation of ex harvester product into components, primarily leaf, twig and bark from the woodchip component.
- Efficient steam extraction of the leaf and twig components, versus the current strategies of whole tree product. This will be essential to reduce the energy consumption and cost associated with oil extraction.
- Efficient drying and densification of leaf and twig material after oil extraction to maximise transport densities and minimise transport costs.
- Automated combustion systems for mallee chip and densified leaf product.

In addition to these basic components, it is essential that work continue on the “Big Picture” components of the potential industry, including gasification/pyrolysis for the potential production of liquid fuels.

Key considerations regarding sugar and mallee products and processing and the impact on the supply chain are tabulated in Appendix 1 of the document.

5. Industry and Business Structures

Industry and business structures will have a significant impact on supply chain development and operation. In particular industry regulation, payment formulae, supply agreements and ownership within the supply chain has influenced innovation in and development of the sugar supply chain. This chapter provides a review of sugar industry and business structures and concludes with considerations and recommendations for mallee industry development.

5.1 Overview

The Australian sugar industry is predominately based on the production of raw sugar. Other uses and by-products include molasses, green energy production from the combustion of bagasse (fibrous waste), low volumes of organic sugar (speciality) and packaged cane trash as garden mulch. Section 4.1 of the report provides greater detail on sugar products and by-products. Refined sugar is regarded as a separate business. The sugar industry supply chain consists of growing, harvesting, transport and milling which is effectively driven by farmers and millers.

The basic profit centre within the sugar industry is the mill area. Both the growing and milling sector is closely dependant on each other due to the perishability of cane and high transport costs. The sugar content (commercial value) of sugarcane starts to deteriorate within 16 hours of being harvested. Sugarcane cannot be economically transported beyond a time and cost limited geographical radius. For both the growing and milling sectors to achieve a profitable outcome, each in turn must be profitable for the economic sustainability of the mill area.

Hildebrand (2002) summarises this relationship:

- Farmers seek to ensure that a mill will accept the cane they will grow and harvest over the season for optimum farm proceeds, to a schedule that averages crop and climate event risks between farmers (farmer equity) and
- The mill seeks to ensure that cane farming is the most profitable use of land in its feeder area, and that its milling capacity is adequate to ensure cane continues to be grown in sufficient quantity by its supplying farmers, in order for the mill to remain economically viable.

Mill areas have various farmer and miller ownership structures however each mill area forms the basic profit centre.

5.2 Institutional / Regulatory Framework

5.2.1 Historical Arrangements

The sugar industry has been in operation for more than 100 years and has been examined in detail many times throughout its history. A relatively rapid change in the institutional / regulatory arrangements has occurred in the last 10 years, to a point where the sugar industry has moved from a highly regulated industry to one of deregulation.

Historically legislation governed most aspects of the industry where development and commercial activity were premised on remunerative price and grower equity (Sugar Industry Oversight Group, 2006). In the early stages of the industry all raw sugar produced in Queensland was compulsory acquired by the Government and sold by a central Sugar Board (the predecessor of the Queensland Sugar Corporation and Queensland Sugar Limited). A land assignment system was introduced whereby cane could only be grown on cane assigned land. Growers were required to deliver cane to designated mills and mills were required to accept all cane grown on assigned land within a mill area. Aspects of the cane supply such as delivery and pricing arrangements were specified in accompanying regulation.

The benefits of government regulation include the establishment of rules to manage industry participants and the provision of certainty which allowed the industry to form. The potential drawbacks include inflexibility which prohibited allowances for changing conditions over time. This also impeded progress and innovation to respond to a changing environment. In 2004 the industry through the introduction of the Queensland Sugar Industry Reform act became partially deregulated permitting sugarcane growers to freely enter into supply contracts with the mill of their choice. In 2005 the Queensland Government entirely deregulated the marketing of Queensland's raw sugar exports allowing the industry to graduate from statutory relationships to contract based commercial relationships.

A review of the development of sugar industry legislation is provided below. Legislation has been strongly influential on the relationship between the growers and milling companies, how they do business and manage the supply chain.

Legislative and review timeline (Source: Sugar Industry Oversight Group, 2006)

1893 *Sugar Works Guarantee Act* authorises the funding of central sugar mills with financial backing by the Queensland Government.

1901 Australian Government places protective import duties on sugar.

1915 Queensland Government passes *Sugar Acquisition Act* and *Regulation of Sugar Cane Prices Act*, which legislate and establish regulatory controls over production levels, marketing and pricing. Though not to the same extent, regulatory controls are also imposed on wages and working conditions within the sugar industry.

1923 Sugar Board in Queensland, established under the *Sugar Acquisition Act 1915*, takes over the authority to acquire and market all raw sugar produced in Queensland.

1925 Queensland legislation establishes the basis for the future CANEGROWERS organisation.

1937 First International Sugar Agreement is negotiated, but does not come into force due to World War II.

1951 Commonwealth Sugar Agreement is reached with the United Kingdom.

1969 International Sugar Agreement commences for a five-year term, Australia still participates in the International Sugar Organisation.

1974 Commonwealth Sugar Agreement is terminated.

1978 Industries Assistance Commission (IAC) conducts an inquiry into the industry.

1983 IAC conducts a second inquiry into the industry and concludes that government assistance to the industry should be substantially reduced; recommendations were not accepted by Australian Government.

1985 Sugar Industry Working Party undertakes a review and makes recommendations similar to those of the IAC. The flexibility of some regulatory controls is increased.

1986 Report by the Bureau of Agricultural Economics, *Efficiency of transport, milling and handling in the sugar industry*; states' regulatory regimes are considered to have inhibited the efficiency of the Australian sugar industry.

1989 Embargo on sugar imports is dismantled and customs tariff is imposed. Senate standing committee inquiry is conducted into tariff levels on future sugar imports.

1990 Qld State Sugar Industry Working Party is convened; recommendations handed down in June.

1991 Australian Government begins phased reduction of tariffs on sugar from AUD115 to AUD55 per tonne. Queensland's *Sugar Acquisition Act* and *Regulation of Sugar Cane Prices Act* are superseded by the *Sugar Industry Act 1991*. This Act removes the authority of the Central Board, replacing the Sugar Board and the Central Sugar Cane Prices Board with the Queensland Sugar Corporation, which is given the responsibility to

develop and implement policy relating to management of the Queensland industry. Also under the aegis of the *Sugar Industry Act 1991*, the Queensland Sugar Corporation is established, on 15 July, 'to provide comprehensively for all matters relating to the promotion and regulation of the sugar industry in Queensland'. Although the 'old' Acts are repealed, many of the practices born of the previous legislation remain and, with the discretionary powers provided to the Queensland Sugar Corporation, the industry remains, in effect, one of the most highly regulated in Australia. Industry Commission review into production, institutional and regulatory arrangements in the sugar industry is established.

1992 Industry Commission report is finalised; the main finding of the report is that 'the regulatory controls applying to the production and marketing of raw sugar in Queensland' are the major factor reducing efficiency of the Australian sugar industry.⁶³ Sugar Industry Task Force is established by the Australian Government Minister for Primary Industries and Energy.

1993 Sugar Industry Task Force reports to the Australia Government Minister for Primary Industries and Energy. The Joint Sugar Industry Infrastructure Programme is announced, with assistance of up to AUD20 million; of this, AUD19 million is allocated to Queensland projects and the balance to New South Wales projects.

1994 Queensland's *Sugar Industry Act 1991* is amended, making some changes to pool prices paid to sugar mill owners in subsequent years and providing for quality standards to be set by the Queensland Sugar Corporation.

1995 Council of Australian Governments reaches agreement on an ambitious plan to enhance competition in Australia, designated as the National Competition Policy. This has a significant effect upon all agricultural industries. To meet its obligations, the Queensland Government establishes the Sugar Industry Review Working Party (SIRWP) to review the *Sugar Industry Act 1991* and import tariff on sugar.

1996 SIRWP reports in November 1996, concluding that the Queensland *Sugar Industry Act 1991* restricts competition in a variety of ways. Over 70 recommendations are made by the SIRWP review. In part they recommend that:

1. the Queensland Government

- continue the compulsory acquisition of all raw sugar produced in Queensland
- retain the single-desk seller of domestic and export sugar, subject to the pricing of domestic sales at export parity prices
- permit growers to negotiate individual agreements with mills and transfer their supply to alternate mills, when collective supply agreements expire

2. the Australian Government remove the customs tariff on raw sugar imports.

1998 Sugar Terminals Limited is established as a special purpose vehicle to transfer the beneficial interests in Queensland's bulk sugar terminals and long-term leases to the growers and millers, who actually pay for them through deductions from sugar pool prices.

1999 New Sugar Industry Act is passed (effective 1 Jan 2000). CANEGROWERS loses its compulsory levy capacity.

2000 *Sugar Industry Amendment Act 2000* establishes Queensland Sugar Limited to replace the Queensland Sugar Corporation.

2002 *Independent assessment of the sugar industry* (the Hildebrand Report) is released by the Australian Government Minister for Agriculture, Fisheries and Forestry.

2003 Sugar Industry Guidance Group is established to prepare an overarching Industry Reform Plan.

2004 The Queensland *Sugar Industry Reform Act 2004* partially deregulates the industry to dismantle statutory cane production areas and permits sugarcane growers to enter supply contracts with the mill of their choice. It also provides for exemption of the compulsory vesting powers when raw sugar is used for specified alternatives, such as ethanol and direct consumption. The Sugar Industry Guidance Group draft industry report is released.

2005 The Queensland Government repeals the vesting powers of Queensland Sugar Limited (effective from 1 January 2006) and deregulates the marketing of Queensland's raw sugar exports.

5.2.2 Cane Payment

The method for making payment for delivered cane has evolved over time in the sugar industry as outlined below. Payment formulae which reward best practice and product quality will be important for the biomass industry, particularly when multiple product streams and markets are being served.

Historically cane payment was arbitrated by government. The cane payment formula was initially developed to divide net proceeds from the sale of raw sugar between the miller and farmer in proportion to their assets. The cane payment formula is a function of the price of sugar and the recoverable sugar content known as commercial cane sugar or CCS. When introduced in 1916 the cane payment formula was based on industry production and performances at the time (i.e. mill standard efficiency of 90%; average cane quality of 12 CCS). The proceeds were effectively split in the ratio of two thirds to the farmer and one third to the miller. Over time this formula provided the basis for cane payment with minor modification by adding a constant that has grown to \$0.578.

Calculating CCS (Source: Canegrowers, 2010)

In most sugarcane growing areas payment of cane is a function of Commercial Cane Sugar otherwise known as CCS (see above). The calculation of CCS assumes that sugarcane contains pure sugar, impurities, water and fibre and that for every kilogram of impurities which is removed at the mill, half a kilogram of sugar is also removed. In effect CCS is equal to the sugar in the cane minus half the impurities. Both the sugar and impurities are difficult to measure directly, however they are relatively easily measured in juice. Sugar is traditionally measured with a polarimeter, which measures how the sugar solution influences polarised light (called pol). Impurities are determined by measuring all of the material which is dissolved (called brix) and taking away the sugar (ie pol).

Therefore:

$$CCS = \text{sugar in cane} - \frac{1}{2} \text{impurities in cane}$$

$$CCS = \text{pol in cane} - \frac{1}{2} (\text{brix in cane} - \text{pol in cane})$$

Because brix and pol in juice are not the same as brix and pol in cane, correction factors which include the cane fibre are built into the CCS formula, which becomes:

$$CCS = \frac{3}{2} P \left(1 - \frac{(F+5)}{100}\right) - \frac{1}{2} Bx \left(1 - \frac{(F+3)}{100}\right)$$

Where:

P is % pol in first expressed juice

Bx is % brix in first expressed juice

F is % fibre in cane

Procedures have been standardised for determining pol, brix and fibre within the industry. Most mills are now using NIR (Near Infra Red Spectroscopy) which allows for a direct measurement of fibre and CCS on each sample.

Today government no longer has a role in negotiating cane supply arrangements. Under the Sugar Industry Act each mill area has to specify cane payment arrangements as part of a cane processing and

supply agreement. The price of cane can be totally different to the traditional “cane payment formula” (i.e. unrelated to sugar price) providing it is agreed to by farmers and millers.

To a large extent the traditional cane payment formula still provides the basis (or similar) for cane payments to the grower with some modification in various regions (hence its importance). The cane payment formula traditionally passes on proceeds to the grower from raw sugar production only. Other outputs such as molasses and bagasse have traditionally been treated as belonging to the mill. Bagasse is used as a fuel source for generation of mill process steam and electricity. Some mills now include a separate factor for a share in molasses sales. Mackay Sugar has extended this to include income from cogeneration and other sources of revenue.

The sugar content or CCS varies during the crushing season. Early in the season, CCS is relatively low before it rises to a peak around September and then falls towards the end of the season. In order to normalise these differences a relative payment system is also applied so that farmers aren't penalised for supplying early or late in the season.

Where the sugar price was once the same for all growers (i.e. outcome of sugar pool through Queensland sugar) it may now vary between mills, depending on the markets in which sugar is sold and local arrangements. Increasingly growers are also marketing their own sugar through futures contracts and hedging the price of sugar over a longer term. Where this occurs, the sugar price locked in by the grower is applied to the cane payment formula to determine both the payment received and the quantity of cane to be supplied (Canegrowers, 2010).

5.2.3 Cane Supply and Processing

The supply of sugarcane to a mill can be negotiated collectively or individually. The sugar act provides the framework for these negotiations and agreements. Where collective negotiating takes place a negotiating team is nominated by millers and farmers and elected to decide on collective agreements. Collective bargaining suits the milling sector given the increased administrative burden of separate agreements if extrapolated across a region. The exception is larger enterprises supplying relatively large volumes of cane or special arrangements.

The Sugar Act sets the framework for negotiations on issues including harvesting, delivery to the mill, transport and handling, acceptance and crushing by the mill and payment by the mill owner for cane. Beyond these minimum requirements farmers and millers can include other terms. Negotiations between a miller and an individual farmer can occur providing an agreement has no adverse effect on other farmers particularly with regards to equitable access during peak sugar.

Cane price can also be negotiated between farmers and millers and is subject to the price of sugar unless the negotiation team decides otherwise. As joint producers of raw sugar farmers and millers can decide on how proceeds will be split although as indicated usual / traditional pricing formulae are adopted.

Within the Sugar Act cane quality is also a consideration and must be part of a cane supply agreement with a mill. Quality programs provide some assurance of standards to meet customer expectations. There is also a mechanism in the Act that allows payment or penalties in relation to quality criteria. In some instances mills have implemented quality based schemes and provides bonuses for cane which reaches a certain standard.

Beyond negotiating arrangements for cane supply, processing and payment, the Sugar Act also provides a mechanism for dispute resolution and mediation for establishing a cane supply agreement. The act is not prescriptive in that it requires farmers and millers to examine issues while allowing them to decide on how to deal with them.

5.3 Ownership within the Supply Chain

5.3.1 Growing

Small scale owner operated farming enterprises account for the majority of sugarcane grown in Australia. Average farm size in the sugar industry is approximately 70 ha with farms ranging from 20 to 2000 ha. The growing sector of the industry comprises over 4000 owner operated cane growing enterprises. A large percentage of these farming operations produce less than 5,000 tonnes of sugarcane per year (~ 50 Ha). In Queensland these farming operations account for 55% of cane produced and in NSW 75%. Regional variations in farm sizes occur, for example, larger farming enterprises are encountered in the Burdekin.

The Sugar Industry Oversight Group (2006) suggested that economies of scale through increasing the operating size of farming enterprises would lead to long term improvements in the cost of production within the industry. Economies of scale could be generated through growth or acquisition although managed scale options provides a less structured approach. Managed scale allows farmers to have a cost profile consistent with a larger enterprise without requiring a change in ownership. This can be achieved by growers acting in concert through cooperation, unincorporated and incorporated joint ventures, share farming arrangements, joint management agreements, farming consortia, or developing a structure that allows farmers to act economically as a larger enterprise, therefore reducing the unit cost of production for it members. Particular examples of this include the harvesting cooperatives that operate in NSW. In some cases harvesting cooperatives have expanded their charter to other aspects of farming including planting.

5.3.2 Harvesting

In recent years the number of harvesting enterprises has declined to 1,000 operators. Productivity rates vary from 13,000 tonnes per harvester to greater than 150,000 tonnes. This is dependent on a number of factors including the topography, historical structure of harvest groups, equipment type and age. Prices per tonne harvested are charged to growers based on an average of harvest group costs. Some variation in these arrangements may occur were there are large haulage distances to the delivery point of the mill transport system.

The capacity of a sugarcane harvester is 16 times the size of an average farm (Hildebrand, 2002) which requires frequent cleaning and movement of equipment to harvest a proportion from each farm in multiple passes or rounds before harvesting is complete. Over time a number of harvest and transport logistical studies have been undertaken to rationalise equipment and to maximise efficiencies. Strategies include the consolidation of land holdings to reduce inefficiencies through continual moving (around grower equity issues). In essence the concept is based on rationalising the harvested area so that harvesters can operate at full capacity. Full capacity for a single machine is regarded to be 100,000 tonnes of sugarcane per year.

Hildebrand (2002) estimated that there were approximately 1,200 harvesters in Queensland with a requirement for less than half, although some areas do have high productivity harvesting arrangements. Generally high cost, difficult to cut farms are cross subsidised within a harvesting group by an easier to cut low cost neighbouring property. Many harvesting contractors operate with little documentation; while machinery has a 4-5 year lifetime with a replacement cost greater than one million dollars (includes harvester and haul out equipment)

Some rationalisation of harvesting structures and operations has occurred and are likely to continue within the industry. Although harvesting represents a significant cost and importance to the sugar industry, harvesting contractors are not normally included in industry negotiations between farmer and miller. A large proportion of the harvesting sector however is administered by farmers.

Harvesting is generally carried out during daylight hours despite mills operating for 24 hours a day (between June and November). In recent years the move towards double shift harvesting (i.e. operate

outside of daylight hours) has become more common to increase machine throughput and to cover high machinery replacement costs. In some areas harvesters also continuously harvest 24 hours a day. Other recent changes have included the consolidation of harvesting groups so that harvesters operate on a large area i.e. improve utilisation of equipment.

Rostering and scheduling creates inefficiencies for transport and machine utilisation. This results in sub-optimal utilisation of harvesters, ancillary equipment, delivery infrastructure (sidings), rolling stock and locomotives (Sugar Industry Oversight Group, 2006). Given harvesters are not operating over the same 24 hour period as the mill, cane bins are used as a buffer / temporary storage which can lead to protracted cut to crush delays and detrimental effects on sugar quality (and cost to the value chain).

A large driver of green cane harvesting was the flexibility of harvesting in excessively wet conditions. In the early adoption of green cane harvesting the significant increase in biomass was somewhat of a barrier as machines could only cut 30-50% of their burnt cane capacity. Within the industry today, the majority of farmers have adopted green cane harvesting.

Generally across the sugar industry harvester operators are paid on an agreed rate per tonne of cane (including extraneous matter and soil) across a harvesting group. This system encourages harvester operators to harvest at high pour rates and machine settings which maximise the amount of cane cut per hour. This behaviour results in increased cane losses, EM levels and soil which impacts on the amount of cane received (i.e. tonnes paid), recoverable sugar (i.e. CCS) obtained and additional costs within the value chain (i.e. increased milling costs). In addition, this payment system doesn't encourage improvements to farm layout (i.e. row length and haul distance) within a harvesting group. Farm layout is particularly sensitive to the actual cost of harvesting.

Within the sugar industry there is scope to explore more effective harvest payment systems which are considerate of the whole supply chain (Figure 5.). This can be achieved by linking grower, harvester and miller interests and using economic incentives to drive harvester performance and implement Harvest Best Practice, HBP (Jones, 2004). At a regional level the Sugar Industry Oversight Group (2006) identified harvesting as the segment within the value chain with the greatest productivity gains.

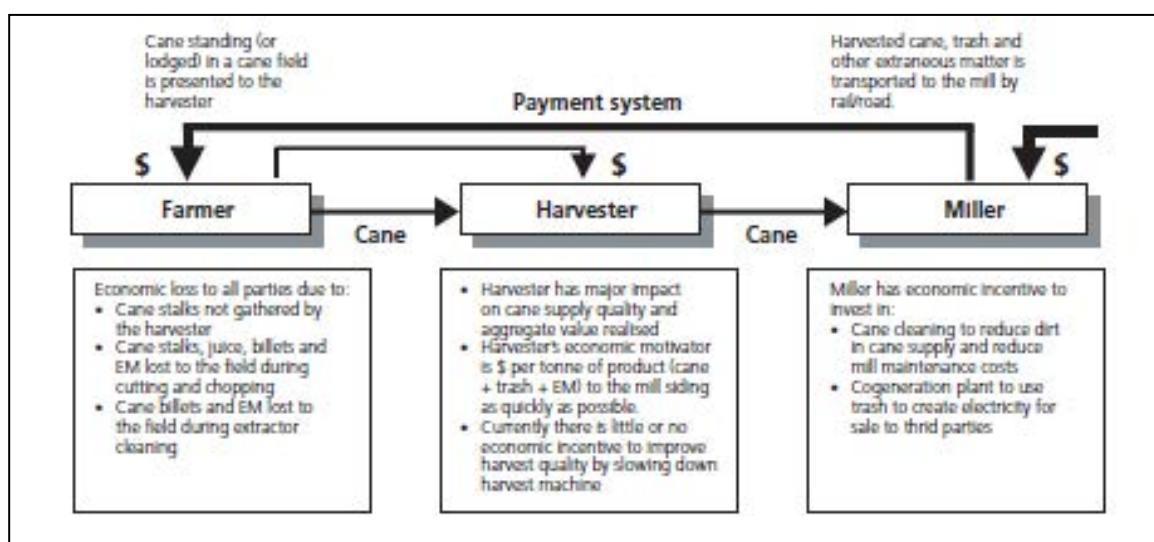

Figure 5.1 Cane supply chain (source Jones, 2004)

Various options have been presented elsewhere in this report (Section 2.6.1). A system based on a dollar rate per tonne plus a share of net revenue gains (option 8 of table 2.11) has been advocated by Jones (2004) as the preferred payment system to ensure incentives are shared across the value chain

(key ingredient for reform). Willcox et al (2005) who commercially trialled a number of these systems across 3 regions within the sugar industry suggested that methods where fuel is charged to the grower send a weak market signal but are still linked to best practice and provide some incentive for change. These methods are the most likely to be adopted in the near future. Notably this method is widely adopted in Maryborough.

5.3.3 Transport

Within the Australian sugar industry sugar mills collectively operate more than 4000 km of narrow gauge railway, which includes 220 locomotives and 50,000 rail bins. Only seven mills are dependant solely on road transport. In some regions cane transport systems rely on computerised transport scheduling to reduce delivery delays. The point of delivery for farmers is either on farm or a nearby rail siding or dump delivery point. In new areas farmers are required to contribute to cane transport costs however generally across the industry this cost is covered by the mill.

Within the sugar industry the cost of transport resides with the mill and as a result there is little incentive for growers to assist in optimising costs and infrastructure. As an example a farm producing a small amount of cane (1,200 tonnes per year) may have a dedicated siding similar to a large farming operation (80,000 tonnes per year) resulting in a significant difference in cost per tonne of cane. Much of this infrastructure was established at a time when cane supply was denser and there was little regard to the scale of farming operations. While there is some resistance to reduce the number of sidings due to this historical precedence some rationalisation has occurred and more is inevitable.

An additional and significant benefit of the cane railway system which is not valued is the diversion of cane transport from public transport infrastructure. Some regions rely solely on road transport and this is likely to increase as cane growing areas become more isolated.

Transport infrastructure within the Qld industry is mainly dependant of narrow gauge rail. Declining production and competing demands for cane between mills has lead to a patchwork of cane farms in established mill areas. Where transport within a mill area has developed around narrow gauge rail the average cost per tonne of sugarcane increases in maintaining the rail network. This patchwork effect also has a flow on effect to the spatial economics of sugarcane transport to the mill. Spatial economics of sugarcane transport are driven by the efficiency of transport (i.e. shorter hauls are more efficient) and the critical mass required to sustain operations.

Sugarcane transported from the edges of sugarcane growing areas need to contribute at least enough revenue to cover the transport and milling costs. Cane transport distance largely determines the real cost of transport which doesn't vary with sugar price therefore fringe areas can negatively impact on a milling region as sugar prices decline. This is a particularly important consideration where the mill is sourcing additional tonnage at the limit of economic transport distances. From the millers perspective this may be justified to underpin existing milling operations and utilisation of assets.

Numerous studies have been conducted in harvest and transport logistical studies however implementation of recommendations from this work has been limited. Given pressures on the industry to diversify and become less dependent on raw sugar production it is likely that this will lead to increased costs per unit of cane for the transport sector. Low margins require a high volume of production to achieve efficient use of capital and diversification which leads to less volume of product and may in fact lead to greater uncertainty across the value chain.

5.3.4 Milling

Within the Australian Sugarcane Industry there are 24 Mills (21 in Qld; 3 in NSW). On average (i.e. industry statistics 2006 to 2010) the milling sector crushes 32 million tonnes of sugarcane and produces 4.4 million tonnes of raw sugar each year. The majority of mills are dated in terms of basic structures and production facilities. The oldest mill operating commenced in 1874 while the majority

of currently operating mills commenced operation between 1875 and 1925. The most recent mill is the Tablelands Mill, which was built in 1998 and was the first new mill in Queensland since 1925.

Mill throughput ranges from 3.3 Mt (Victoria Mill) to 433,000 Tonnes (Rocky Point). Australian mills produce bulk raw sugar except for the Tablelands mill which produces syrup that is manufactured into raw sugar at other mills. In addition refineries are located at Racecourse, Millaquin and Harwood mills with another major refinery located in Melbourne. The production of refined sugar is to a large extent is considered a separate part of the sugar industry. Apart from crushing sugarcane and producing raw sugar, the milling sector also coordinates harvesting and transport arrangements which are in effect an extension to the front end of the mill. Harvesting and transport is coordinated to match the crushing rate of the mill.

Except for two mills, sugarcane is crushed 24 hours a day, 7 days a week for a period of 22 – 24 weeks (June – November). Continuous crushing proves a better utilisation of harvesting, transport and milling capital. Updating of operating equipment within these mills has been in response to cane land expansion and necessary maintenance or replacement. Other areas of significant investment include automation and technical enhancement of existing processing equipment. In recent times cogeneration of electricity has been used to finance replacement of boilers and improvement in thermal efficiency. The return on these investments is a result of renewable energy initiatives which cross subsidise the raw sugar value chain.

The development of the Tableland Mill by Bundaberg Sugar Ltd was novel at the time. In simple terms the feasibility process was based on working out how much cane could be grown in the area (based on suitable land, yield, economics etc), then transport costs were examined to see how much cane could be sourced within an economic supply area. Based on this information, building the mill (i.e. most costs are fixed) was dependant on achieving particular economic criteria / scale (per comm. M. Smith). Once built the harvest and transport system for the mill was owned and operated by Bundaberg Sugar Ltd and based on a just in time delivery system. The Tableland Mill has recently changed ownership and is now under the control of MSF Sugar.

Ownership of sugar mills has been concentrated in recent years. In 1980, 19 companies operated 33 mills, whereas today 10 companies operate 25 mills. In 2006 farmer cooperatives / owned mills produced 40% of Australia's raw sugar (Sugar Industry Oversight Group, 2006).

Table 5.1 Ownership of Australian sugar mills

Ownership Structure	Australian Milling Companies	Sugar Mills
Public Companies	MSF Sugar	Maryborough; Mulgrave; South Johnstone; Tableland
	Sucrogen	Victoria; Macknade; Invicta; Pioneer; Kalamia; Inkerman; Plane Creek
	Tully Sugar Limited	Tully
	Mackay Sugar Co-operative Association Limited	Farleigh, Racecourse, Marian
Public Unlisted Companies / Grower-Owned Mills	Mossman Central Mill Company Limited	Mossman
	Bundaberg Sugar Ltd	Bingera, Millaquin
	Isis Central Sugar Mill Co Limited	Isis
	New South Wales Sugar Milling Co-operative Limited	Condong, Broadwater and Harwood
Co-operative / Grower-Owned Mills	Proserpine Co-operative Sugar Milling Association Limited	Proserpine
Private Companies	W H Heck & Sons Pty Limited	Rocky Point

Despite deregulation of the industry over 90% of raw sugar exports are marketed through Queensland Sugar Limited (QSL). Eight mills supply raw sugar to QSL on a rolling 3 year contract known as Raw Sugar Supply Agreements (RSSAs). The Raw Sugar Supply Agreements (RSSAs) are the supply contracts under which QSL aggregates and pools raw sugar supplies, which is sold on the world market. In addition QSL provides pricing, financing, risk management, shipping and logistics services to its sugar mill customers. Mills contract to supply raw sugar to QSL on a rolling three-year basis, and at the end of June each year have the opportunity to not roll over their contract, effectively giving three years' notice of their intention to withdraw from QSL's pool (QSL, 2011).

An example of sugarcane milling, harvesting, transporting and growing arrangements is provided below for the NSW sugar industry. NSW is of special relevance to the mallee industry given their move from burnt cane harvesting to whole crop harvesting to increase cogeneration capacity and the impact this had on factory operations, harvest and transport efficiencies and profitability.

Sugar Industry Illustrative Example (NSW Sugar Industry)

Milling

Overview: Broadwater Mill is located on the Richmond River in Northern New South Wales, south of Ballina, and began its operations in 1881. Broadwater mill is one of 3 sugar mills owned and operated by the NSW Sugar Milling Co-operative Limited. Other milling interests include Condong Mill (Tweed River) and Harwood Mill (Clarence River). The NSW Sugar Milling Co-operative Limited (Sunshine Sugar) was formed when cane growers purchased the three NSW sugar mills from CSR in 1978.

In 2008 a partnership was formed with Delta Electricity (Sunshine Electricity) to commission two cogeneration power plants at Broadwater and Condong, which generate renewable electricity primarily from bagasse and supplemented by wood biomass materials. Total construction costs on the upgrades were \$220 M. Drivers for this initiative included the need to replace existing boilers (mill), the opportunity of a diversified income stream (renewable energy market) and productivity improvements (i.e. based on less sugar loss from whole of crop harvest). A number of factors have limited the

success of this venture and whole of crop harvesting.



Broadwater Mill on the Richmond River

(source: Sunshine Sugar)

Milling Statistics & Cane Supply: The Broadwater Mill has a capacity to crush over 1,000,000 tonnes of sugarcane annually with an average of approximately 835,000 tonnes from 2005 – 2010 (Variety Productivity Report, 2010 season Broadwater). The mill operates at a crushing rate of 260 tonnes per hour with a maximum of 280 tonnes per hour. The mill relies on 5,000 – 6,000 tonnes per week of biomass to maintain electricity generation operations. In comparison to the power plants at Broadwater and Condong, other cogeneration projects within the sugar industry have not been based on whole of crop harvesting. These projects rely on significant supplies of surplus bagasse from a larger cane supply area.

Cogeneration: Since commissioning in 2008 a number of factors have impacted on the success of whole of crop harvesting and the cogeneration venture. The industry in 2010 reverted back from whole of crop harvesting and the cogeneration plant went into receivership (from 2010). The main factors limiting whole of crop harvesting and processing include: i) the need to develop a cost effective trash separation plant at the mill and ii) high transport costs due to lower than expected bulk densities for whole of crop cane. The main factor significantly influencing the feasibility of the cogeneration venture is a low REC price due to flooding of the market through solar initiatives (REC price reduced to \$25) and adequate biomass supply (primarily influenced by whole of crop experience and supplementary materials) .

Forced to make financial concessions in the implementation of the cogeneration plant, preliminary trials indicated that it would be feasible for the mill to handle the whole crop with a relatively minor reduction in performance (i.e. recoverable sugar). The experience in practice was significantly different with a higher percentage of unrecoverable sugar losses and significantly lower crushing rate. Similarly preliminary trials had indicated that bulk densities could be achieved so that multi-lift bins could reach their mass limits (i.e. 22.5 tonnes). In practice bin weights were between 15 – 18 tonnes. Sunshine sugar is currently investigating the development of a trash separation plant and methods to increase the bulk density of cane bins through whole of crop harvesting.

Cane supply arrangements: The NSW Sugar Milling Cooperative has a 5 year contract / cane supply agreement known as a Memorandum of Agreement. The price growers receive reflects the raw sugar price (which is influenced by the local sale of raw sugar for refinement) and other adjustments / returns from ownership of milling operations. Potential disputes between the distribution of funds between the miller and the grower is somewhat minimised through the cooperative ownership of the mills.

Transport

Overview: Cane supply is transported to the mill from or near farm by multi-lift bins and semi-trailers. In 2007 a new road transport system was implemented to facilitate whole of crop harvesting. This included super trailers and super sized multi-lift bins (90 cubic metre capacity) fitted with auto-tarping systems. Since the implementation of the new transport system the mill has reverted back from whole of crop harvesting due to processing issues discussed. A key factor determining the overall feasibility of the initiative was the increased transport costs due to maximum bin weights of 15-18 tonnes (compared to mass limits of 22.5 tonnes) that could be achieved.



Road Transport Trucks

(source: Sunshine Sugar)

Ownership: Sunshine Sugar leases a fleet of 31 trucks (13 trucks service Broadwater Mill) that primarily operate during the sugarcane harvest season. The cooperative effectively owns (i.e. will have ownership of trailers and bins at the end of the current transport contract) and maintains the multi-lift bins and multi-lift semitrailers used for transporting sugarcane to the mill. Given transport equipment is utilised over a period of 6 months (June – November), to better utilise this equipment during the non crushing period is being investigated. Options include the local handling of wood based biomass material.

Logistics: The crushing rate of the mill is adjusted continuously to match the supply of cane delivered to the mill. Trucks are managed and coordinated from the mill via a computerised scheduling system (FREDD). An optimum delivery schedule equates to an average return interval of trucks every 52 minutes. The logistics surrounding transport and cane supply are primarily based on time over distance. Where additional woodchip has been sourced locally better efficiencies have been achieved with super size multi-lift bins over B-double trailers.

Harvesting

Overview: . In NSW crops are generally harvested every 2 years. Harvesters and haul out equipment is setup for extremely wet weather harvesting conditions (see below). The NSW sugarcane industry claim to have highly efficient harvesting systems. Sugarcane harvesters cut and load into infield transporters (haul outs) which transport cane to pads on or near the farm and either tip or elevate cane into Multi-lift bins. These bins are then transported to the mill by road

There are currently 4 harvesting cooperatives in the Broadwater mill area which operates 7 harvesters. The harvesting sector in NSW has undergone significant rationalisation in recent times with harvesters cutting in excess of 80,000 tonnes per year compared to an industry average of less than 40,000 tonnes. The sector recognises that further rationalisation is achievable with an optimum of 100,000 tonnes per harvester (per year) targeted to maintain cost competitiveness.



Harvester & Buggy

(source: Sunshine Sugar)



Transferring cane from buggy to bin for transport by road

(source: Sunshine Sugar)

Ownership: Harvesting is conducted by grower owned harvesting cooperatives / partnerships. Each harvesting co-op is managed by an operations manager who is responsible for general management of the harvesting equipment including repairs, maintenance and replacement. The operations manager also oversees the daily harvesting operations. The harvesting cooperative is operated as a single sustainable business unit.

Payment and Costs: Harvesting is contracted on the basis of a fixed price per tonne of cane delivered to multi-lift transport bins located on / near the farm. Some increase in harvesting costs may be negotiated on an individual basis where harvesting costs are likely to be significantly more than the basic fixed cost. Typical examples include fields that are poorly presented for mechanical harvesting such as short rows, narrow and difficult to navigate headlands.

Penalties / Performance Criteria: There are no criteria in place for assessing cane quality and harvester performance (and therefore no penalties). There is however a bonus / penalty scheme based on appropriate bin weights.

Growing

Overview: The NSW sugar industry largely comprises of small privately owned farming enterprises with an average size of 60 Ha. Each farm harvests around half the cultivated area every year given the majority of the NSW sugar industry operates on a two year cropping cycle. Three quarters of the region's farms yield less than 5,000 tonnes per year, the balance between 5,000 and 15,000 tonnes, with only a handful of farms producing more than 15,000 tonnes annually (Sunshine Sugar, 2005). Given the small farm sizes (i.e. smaller than industry average) many of these growers rely on off farm income. This highlights the importance of sharing equipment and harvesting by grower owned co-operatives or partnerships.



Planting Sugar Cane

(source: Sunshine Sugar)

Cane payments:

The cane payment system is largely based on the traditional cane payment formula previously described. With the introduction of whole of crop harvesting the payment system changed from being based on CCS to payment on pol. Modification to the cane payment formula was mainly due to over penalising on impurities (function of CCS formula), which were much larger than in the traditional burnt cane harvesting system. Since the introduction of the new payment system the NSW Sugar industry has reverted back to burnt cane harvesting and away from whole of crop harvesting, however the revised payment system remains. During whole of crop harvesting, growers were paid \$16 / tonne of fibre, measured by NIR under a separate agreement.

5.4 Ownership and Implications

Farmer and miller ownership within the raw sugar value chain has many different models. At change points along the value chain (i.e. growing, harvesting, transport and milling) competition for returns occurs, which requires negotiation. The model with the least conflict is one which has the fewest changes in ownership throughout the chain. The basic competition within the value chain is the negotiation of returns to the farmer's cane input versus millers manufacturing input (Hildebrand, 2002)

Along the value chain there are other levels of competition such as farmer vs. farmer and farmer vs. harvester. To reduce competition at harvest due to periods when the sugar content is highest within the season, at a farmer vs. farmer level harvesting is scheduled / rostered so that the crop is progressively harvested in a number of rounds throughout the season providing growers with a share of the harvest period. At a farmer vs. harvester level if harvesting is contracted then contractors are paid at a negotiated unit fee which as mentioned, is usually based on an average fee across the group regardless of actual cost (i.e. cross subsidy). In some regions harvester monitoring systems have been installed on machinery to obtain a better idea of actual costs with a view of translating these costs to the grower.

5.4.1 Implications along value chain

Hildebrand (2002) suggests that if all of the value chain is owned by the miller then there is least conflict and no competition until sugar is marketed. This model represents a small proportion of the industry although a significant proportion of the Brazilian sugar industry operates in this way. Conversely a value chain owned by the farmer (apart from competition between farmer vs. farmer and farmer vs. harvester) is the next least likely model for competition. It was noted that the farmer owned model in practice operates where the farmer negotiates hard for the on farm inputs (i.e. farm / mill transfer stage) rather than wait for proceeds to be split after the point of sale. The farmer owned model (i.e. cooperative) occurs in NSW. Hildebrand (2002) noted a low level of farmer/mill conflict and good cooperation resulting in high harvesting efficiency (see illustrative example).

5.4.2 Ownership models within value chain

The sugar industry has a number of ownership models across the sugar industry including cooperative mills, proprietary mills, public and private mills. In addition some proprietary and public mill groups own farms. Harvesting is done by contractor, harvesting cooperative, or farmer. Mixed ownership within the value chain has had variable results. It has been observed that the variability in performance across the value chain is less dependent on the ownership model and more dependent on the cooperation and commitment between each sector in sharing mill area goals. Hildebrand (2002) suggested that this cooperation and commitment is dependent on a shared goal for the mill area as the basic profit centre.

5.5 Suggested Industry and Business Structures for Mallee

Within the sugar industry costs are generally averaged across participants, individuals are not always aware of their costs (Sugar Industry Oversight Group, 2006). It is argued that streamlining the value chain is essential to ensure optimal mill throughput and a reliable cane supply. Sustainability will be enhanced through the identification and targeting of real costs. Other mechanisms to ensure supply reliability include long term contracts and performance based incentives.

Harvest and transport is both a significant component and cost within the cane supply system. 30% of costs in the value chain are associated with harvesting and transport of sugarcane. Within harvesting and transport there appears to be significant inefficiencies embedded within these components of the value chain. This is principally a result of divided responsibilities between the grower and the miller. The cost of harvesting is the grower's responsibility while the cost of transport is the responsibility of the mill. Across some regions within the sugar industry a reduction in the number of harvesting operations and optimising existing groups are demonstrating some benefits.

Ideally the harvest and transport system could be more easily optimised if owned by a single party managing the process from standing cane in the field to cane delivered to the mill. In practice the harvest and transport system involves multiple combinations of ownership including farmers (hundreds), contract harvesters (several to many), contract truck transport and the sugar mill. Hildebrand (2002) and others (Sugar Industry Oversight Group, 2006) identified harvest and transport as a priority for quantum gains in productivity.

5.6 Lessons for the Mallee industry from Sugar

Institutional and regulatory arrangements have had a profound impact on development of the sugar supply chain. In particular, development of a cane payment formula that accounts for quality of cane delivered has been significant in improving supply chain performance. Pricing arrangements are now negotiated regionally based on an industry framework. In the mallee industry, particularly when there are multiple products and markets, appropriate payment mechanisms need to be considered.

The sugar industry has a number of ownership models. Generally the greater the proportion of the supply chain owned by a single entity (eg a cooperative) the greater the efficiency and lower the conflict. Notwithstanding ownership issues, good performance across the value chain results when there is cooperation and commitment between each sector in sharing business proceeds.

Based on the lessons learnt from the Sugar Industry, to achieve a sustainable biomass industry, the Mallee industry needs to streamline the value chain by establishing an intermediary organisation / party to facilitate harvesting, transport and supply arrangements. This will in turn limit capital requirements and multiple combinations of ownership, potential conflicts and costs. This will be particularly important for the Mallee industry to consider given the interdependence of the grower and the processor is quite different to the sugar industry experience. It is unlikely that supply arrangements will be driven by necessity and more likely via a commercial opportunity. Alternatively the cooperative harvesting groups / partnerships, as encountered in the NSW Sugar Industry, provide a good example of how the growing sector, consisting of relatively small scale operators can maintain ownership of the supply chain while operating a highly efficient harvest and transport system.

Prior to these considerations a key ingredient, is the ability to establish confidence through long term contracts / supply agreements. This is particularly important in the Sugar industry and likely to be just as important in the supply of Mallee Biomass. This needs to be informed by the availability of material and the feasibility of supply, which like the sugar industry underpins the profitability and economic stability of a cane supply area which acts as the basic profit centre (a view point the Mallee industry should adopt). Whilst the business and industry structures described provide the mechanism for things to occur, there remains an underlying requirement for a critical mass of supply within an

economic radius. This is certainly the experience within the sugar industry where various ownership models and structures are in place and yet a number of mills have closed in recent years.

Key considerations regarding sugar and mallee industry and business structures are summarised in Appendix 1 of the document.

6. Supply Chain Planning and Management

6.1 Drivers of Supply Chain Efficiency

Coordination between the producer, processor and purchaser is generally driven by a need to increase efficiency and profitability which may be a result of increased competitiveness or changing production and market conditions. Increased coordination requires detailed planning and management of the supply chain, for which a range of tools and procedures have been developed in the sugar industry and are described in this chapter, with discussion on potential use in the mallee biomass supply chain. Coordination is also reliant on effective cooperation between the participants in the supply chain.

The term supply chain and value chain is often used interchangeably but have different meanings as defined by SRDC (2006b).

Supply chain: Refers to the physical flow of materials between the various sectors of the industry — growing, harvesting, transport, milling, transport & storage, marketing, distribution. In a supply chain, the output from each sector becomes an input for the next sector in the chain.

Value chain: Refers to the flow of revenue and the amount of value added at each step along that chain. Thus, value chain management seeks to use planning and cooperation to maximise the total revenue (and customer satisfaction) produced at the end of the chain, and to distribute that revenue fairly between those who have contributed to its generation. The value chain characteristics typically shape the technical requirements of the supply chain.

Sugarcane when harvested is a perishable product, and like biomass has no value at the farm gate. Value is added through transport to the processing facility and its subsequent processing into sugar, electricity through cogeneration, by-products and through storage, marketing and distribution to the customer. The sugar industry thus operates as a value chain where value is added along the chain (SRDC, 2006b). Supply of biomass for bioenergy has a similar value chain.

The sugar industry has been deregulating over last 100 years which has driven change and need for efficient supply processes, as has a volatile sugar price, fluctuating exchange rates and low yields resulting from periods of drought or pest and disease. The mallee industry initially arose due to the need in Western Australia to increase the use of stored soil moisture from deep in the soil profile and reduce the potential spread of dryland salinity and other environmental benefits. This created the situation where there is a resource seeking a market, which has coincided with an emerging need for renewable energy sector seeking a low-cost resource.

The prospective market for whole tree biomass as a renewable energy and electricity resource has initiated demand for a viable supply chain. Key drivers for this include:

- A highly dispersed production area spread over large distances in low productivity landscape.
- An immature industry with a poorly established market and a declining rate of mallee planting owing to lack of a price signal.
- Limited planning to date on sustainable supply or value chains and no organisation with overarching responsibility, leading to horizontal stratification of planning and decision making in an industry that must be vertically integrated if it is to achieve the required high levels of efficiency.
- Marginable economics for converting biomass to electricity and other byproducts.
- Mallee production which is generally regarded as non-core business in a cereal cropping farming enterprise.

- The Mallee tree is particularly difficult to harvest and process cost effectively owing to its physical characteristics and plant layout.

The structure of an industry and its participants will affect the supply chain. For example the Australian sugar industry is structured with predominately family owned farms, and a range of ownership structures for harvesting. Cooperative or company owned mills are responsible for cane transport, the manufacture of sugar and other products, and now, with a deregulated environment, for contracting storage, marketing and shipping. This means that there are many profit centres with each centre and sector seeking to maximise its income and minimise its costs (SRDC 2006b). Individual sector goals, however, may impose costs across the entire value chain such that whole-of-system profitability is not maximised. Opportunities exist, therefore, for more integrated management of the value chain to enhance revenue and cost efficiency for the benefit of all industry participants (SRDC 2006b). A key driver in the cane industry has been a cane payment formula based on quality of the product delivered, which is impacted by operation of the supply chain in terms of delivery delays and impurities from the field.

The Mallee Industry in Western Australia is largely structured around independent wheat farmers who have no strong links to biomass markets and processors and for which there is no established harvest and transport system. Biomass processors are unlikely to manage the supply chain, but one value chain option is that a large central processor will engage or form an agent to occupy a “middle-man” role. Farmers could similarly form a cooperative or other corporate structure to be the middle-man.

A key part of managing the supply chain will be in product diversification. This is discussed in greater detail in Chapter 4. Diversification within the sugar industry has considered production of renewable energy from ethanol or electricity co-generation and other possible new enterprises, such as the production of fibre-based products (paper, packaging, etc.) or lactic acid and other chemical by-products, livestock feed and fertilisers products.

Product diversification for Mallee biomass is also likely, with products including electricity, eucalyptus oil, and the use of pyrolysis to produce liquid fuels (via bio-crude oil or Fischer Tropsch synthesis), biochar and chemicals. This diverse product base will also affect supply chain management. Sugarcane product diversification evolved from an established sugar market which was able to sustain development of new product streams. Development of an established biomass market will be required to support development of sustainable biomass supply chains. It is not clear whether this large scale market will be for electricity generation or the bio-oil market.

Bezuidenhout and Bodhanya (2010) identify a supply chain as being a composition (or framework) of five important building blocks Figure 6.1. The value chain is concerned with systems properties describing value-adding, value loss and distribution of benefits throughout the chain. Second, a material handling chain, concerns the physical equipment and processes used to enable value adding. The third dimension, viz. a collaboration chain, focuses on the way stakeholders collaborate and co-manage the material handling activity. Fourth, the collaboration chain is held together through an effective information chain that enables stakeholders to manage their system. Finally, only once these four chains are understood and well managed, could one consider integrated system innovations where all processes are aligned to enhance efficiency. Bezuidenhout and Bodhanya (2010) suggest that the interaction between the different above-mentioned chains is critical and any innovation that does not consider all these dimensions simultaneously will probably fail.

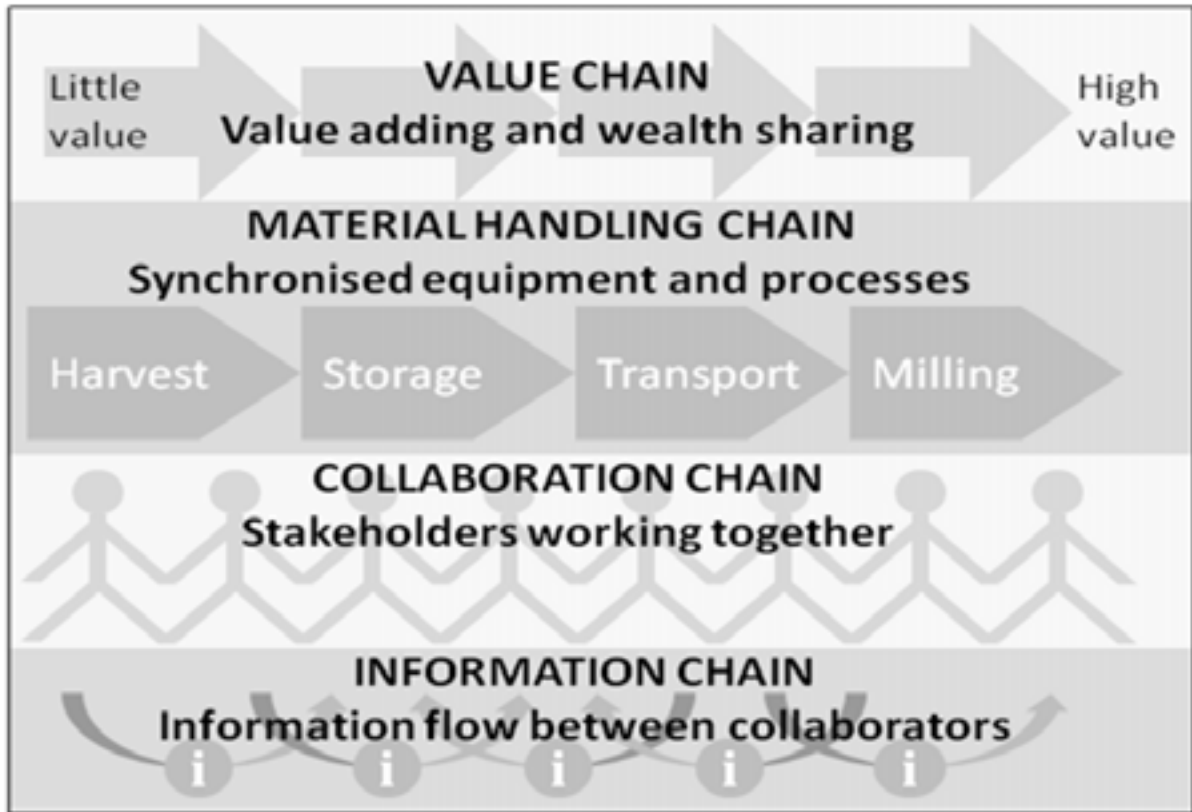

Figure 6.1 Building blocks of the supply chain (Bezuidenhout and Bodhanya (2010))

Agricultural supply chains are often more complex compared to other commodities. Bezuidenhout and Bodhanya (2010) highlight the need to identify:

- where along the supply chain improvements can be made,
- which tools will be the most appropriate drivers of change, and
- in what way should policies and management be altered to support possible opportunities.

In the sugar industry the supply chain is complex containing trade-offs and unpredictable outcomes. The introduction of alternative products introduces more system complexity but adds resilience. Fragmentation and especially grower miller conflict is universally prevalent (Bezuidenhout and Bodhanya, 2010). In particular the cane payment system promotes risk shifting between parties and is often perceived as a disincentive towards innovation and system integration. Industry leadership and sufficient government support have been essential to drive improvements. The mallee supply chain will require similar trade-offs especially with multiple product streams.

On the downstream side of the supply chain commodity-type products, such as sugar and biomass, demand lean supply chain principles. However, upstream, the supply chain can comprise of a multitude of autonomous producers with unsynchronised and individually focused decision-making incentives. In addition, as a result of climatic variability, upstream supplies often produce inconsistent volumes and qualities. The latter characteristics demand more agile supply chain principles and hence create potentially contradictory goals within the integrated chain. As a result, upstream production chains are often over capitalised (Bezuidenhout and Bodhanya, 2010). Under-utilisation is not necessarily a problem when a certain level of risk mitigation is incorporated into the system to create resilience.

6.2 Integration Across the Supply Chain

Traditionally the agricultural supply chain can be seen as the elements of production, harvest and transport and processing. A range of decisions are required at various levels to optimise this supply chain. Some of these are logistic and operational in nature and others are strategic.

Gaucher et al (2003) identify a number of key decisions along the supply chain for the sugar industry, some of which are relevant to the Mallee woody crop industry.

Production - Supply area to meet supply agreement, optimal variety mix (product quality, yield, disease, drought, risk), harvest timing (to optimise product quality and plant age), field location and layout (maximise production, harvest efficiency, soil/drainage issues).

Harvest and Transport – Capacity planning, utilisation efficiency, scheduling deliveries, maximizing haul load, matching harvest/haul capacity, stockpiling buffers, reduced delivery delays.

Processing – Biomass supply for optimum capacity throughout the season, optimum season length. Schedule supply areas to deliver optimum product quality.

Interaction between these elements is important as the decisions made in one area will impact the others. For example decisions made by sugar millers regarding mill capacity, the location of mill and transloading centres, and delivery allocations, will impact on the choices made by growers regarding mechanisation and harvest management (Gaucher et al, 2003). In turn, decisions made by growers regarding variety selection, harvest capacity and work organisation, will impact on milling efficiency. Poor cane quality will reduce crushing capacity, while irregular deliveries will disrupt the continuity of mill supply. Intermediate operators involved in cane flow management, such as harvest contractors and hauliers, will also affect the supply process. Total sugar production at mill area level thus depends on the efficient functioning of these technical interfaces, as well as on each stakeholder's management processes (Gaucher et al, 2003).

Many of these elements are relevant to the Mallee Industry. Biomass supply will be driven by market requirements with block plantings near the processor supplemented with biomass as part of integrated farming systems. Biomass processors are likely to set the price based on competing products but are unlikely to have interest in controlling the supply chain.

Key issues to consider in the developing a sustainable supply chain for the Mallee woody crop industry will include:

- How to match capacities of the processor and harvest-transport supply system with the biomass supply including location of processing facility relative to the supply area.
- How to organise the supply area in order to transport biomass from the fields to the plant, location and capacity of transloading centres, role of hauliers and contractors.
- Which planning and operation rules would be efficient and in line with the objectives and constraints of each stakeholder: season length and dates, delivery allocation and flow monitoring.

In most cases these are site specific issues that need to be resolved locally. Integration across the supply chain is complex and alternative products may introduce substantial changes to the supply chain, the impacts of which will be difficult to predict.

Modelling offers insights into the impacts of, and benefits from changes to value chains (Thorburn, 2006) but has generally been applied only to one or two sectors of the Australian sugar value chain. Thorburn et al (2006) report on modelling the whole of the chain in order to evaluate diversification options. In particular the additional income from electricity and Renewable Energy Certificates sales weighed against the costs of operating and, for some scenarios, constructing the co-generation facility

as well as the costs associated with (1) productivity reduction associated with the loss of trash from the field, (2) harvesting and transporting to the mill the additional material, and (3) the impact of increased trash on sugar mill operations (Thorburn et al, 2006).

A key opportunity has been identified for sugar cane as whole crop harvesting, to maximise fuel for electricity co-generation. Whole crop harvesting represents a substantial change to the traditional supply chain and has been discussed in the Case study for NSW in section 5.3.4 of this report. Harvesters generally aim to minimise the amount of trash harvested with the cane. Harvesting the whole crop will:

- Slow the harvesting process.
- Increase the amount of material to be transported from the harvester to the mill.
- Reduce the efficiency of sugar extraction in the milling process.
- At the mill, whole crop harvesting will require new infrastructure for (1) separation of trash and cane at the mill prior to crushing the cane to minimise the impact on mill efficiency, and (2) maximising electricity production (increased generation capacity, upgrading mill components, etc.).
- At the farm level, retaining trash on the soil surface trash increases sugarcane yields in many environments and so its removal may impact future production.

The logistical problems of handling increased volumes of material in the harvesting and transport sectors and the negative impacts at the farm and mill factory need to be out-weighed by the additional revenue from increased production of electricity for export and the Renewable Energy Certificates (RECs) associated with the generation of renewable power.

6.3 Coordination and Collaboration

Experience in the sugar industry over many years has demonstrated that a technical focus on the planning and modelling of better supply chains has little value unless there is a clear collective interest by all participants (Figure 6.1). Coordination and collaboration is imperative and starts with a clear vision by all stakeholders across the value chain. In the sugar context this has been identified in the text box below (SRDC 2006b). This approach will be useful to help the mallee industry develop a collective view on industry supply chain development for a specific region.

Vision of Sugar Industry for a Sustainable Supply Chain (SRDC, 2006)

Value Chain

- Improvements across the entire value chain on a local region or mill area context.
- Stronger participation from sector participants, leading to a better chance of adoption.

Farming Sector

- Evolution of larger production units (through aggregation, farming cooperatives, or share farming) to realize economies of scale.
- Development of location-specific farming systems that benefit both the farming sector and the value chain as a whole.
- Improved yields and more efficient use inputs of water and other inputs, leading to enhanced economic and environmental performance.
- Improved varieties and better advisory systems for production management. Increased use of contractors in farming operations.
- Individual negotiated cane supply contracts.

Harvesting and transport Sector

- Better integration of harvesting and transport operations with more effective use of capital.
- Fewer harvesting groups handling much larger tonnages, with longer harvesting hours per day, and longer seasons.
- Geographical harvesting to capture regional trends.
- Rationalization of sidings and loading pads with more efficient transport systems.
- Improved timely communication of cane yield and cane quality information to growers and harvesters allowing real-time modifications to operations.
- New payment systems and contracts between miller, grower, and harvester to provide appropriate incentives to all parties to improve performance.

Milling and marketing sector

- Fewer mills handling larger tonnages of cane and making better use of capital.
- Greater diversity of products derived from sugarcane and cane lands. Production of electricity, ethanol, and animal feeds will be higher.
- Milling by-products will be utilised more efficiently. Some completely new products such as bio-plastics and biopharmaceuticals will be in early trials.
- The industry will be fully deregulated and this will lead to closer and more direct business relationships between millers, their suppliers and their various customers.

A key issue will be to define who the Mallee Stakeholders are, now and into the future, their collective vision, the level of regulation in place, the level of trust between parties and the level of sharing and planning to date. Stakeholders will include the following Groups:

1. Seedling nurseries and contract tree planters.
2. Farmers.
3. Harvesting contractors, including haulout operators.
4. Road transport operators.
5. Preliminary biomass processors.
6. Biomass conversion industries.
7. Consumers of the products from conversion industries.
8. CRC, university and public sector industry development workers.
9. Private sector industry development individuals and corporations other than farmers.

Current linkages across stakeholder groups are discussed below.

- There is close contact between nurseries/planters and farmers, however the increasing numbers of mallee being bulldozed out in WA indicates disengagement by farmers.
- Harvesting contractors don't exist yet however harvesting technologies are rapidly developing and will require an appropriate business model.
- Road transport operators are not engaged as yet, however failure to vertically integrate harvesters and road transport will impact profit margins.
- The concept of preliminary biomass processing, or upgrading, has little currency as yet. Most people see a large biomass conversion industry (eg power generator) being the sole processor. Such large industries have an expectation that supply will be just in time, externally managed with minimal stockpile requirements for the processor. There is a perception that preliminary processors would impose a risk for large scale processors, because if farmers extend their influence into the preliminary processing they will be in a position to sell partially upgraded material to other markets.
- Large energy processors are currently the most prominent biomass conversion industries. They are large organisations and are generally reluctant to get too involved with farmers and supply chains.
- It is debatable whether the scale at which groups 1-5 are able to operate now or in the near future is compatible with the minimum scale at which large biomass processing corporations can function. Consideration has to be given to build capacity in groups 1-5 by developing new small industries in 6, and so developing the capacity to underpin large industries like electricity generators in the longer term.
- Consumers range between people connected to the electricity grid to a variety of potential customers who are probably largely unaware of the existence of mallees. The most significant role here is possibly through political routes and recent successes in raising the awareness of bioenergy options.
- There is a range of small R&D organisations, public and private, investigating new harvesting technologies, farming systems and near-commercial biomass conversion processes, such as various forms of pyrolysis to produce syngas or bio-oil. These groups are likely to become dominant in uses and markets for biomass within 10-15 years, though some talk of being ready for commercialisation now.
- Private sector industry groups are showing an interest in developing and operating components of the supply chain and recognise opportunity for profitable ventures as the market develops.

There is at this point very little collective vision, trust and planning in the mallee biomass industry and the linkages described above are generally extended only as far as each group chooses to serve their own immediate needs. This is inevitable as there is no overarching responsible entity, from which might develop a collective vision in the absence of an actual industry.

The need for cooperation to support integration of Value Chains has also been identified by O Keefe (1997) and is illustrated in Figure 6.2. Transaction costs are reduced in an integrated value chain because trust and strategic alignment replace contracts and negotiating tactics; time spent negotiating is replaced with time spent developing joint strategies to create more income or reduce costs (Millford, 2002).

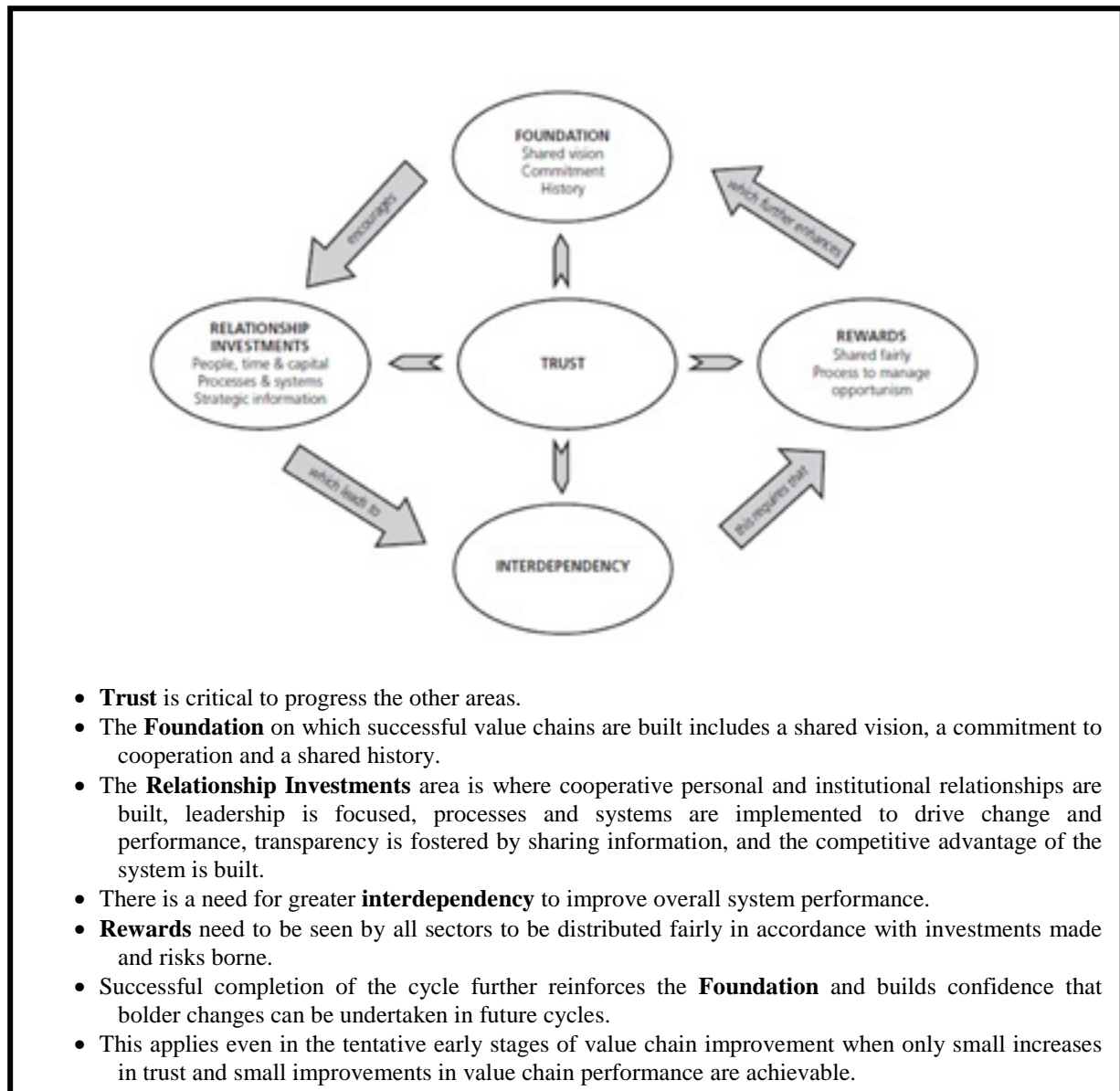

Figure 6.2 Cooperation requirement for value chains (SRDC, 2006b and O Keefe, 1997)

A key to successful implementation in the sugar industry has been strong industry support via local reference groups and technical working groups to ensure a systems view of the value chain.

6.4 Planning, Management Tools and Modelling

The sugar industry has paid significant attention to planning and management tools for supply chain management. This has been both at a strategic whole of supply area level and an operational individual delivery chain level:

Strategic level:

- Overall weekly cane supply through the season across the supply area; production areas and volumes, quality, impact of weather on supply, optimum location of production areas, length of crushing season, investment in capacity, rationalisation of mill capacity and transport systems.

Operational Level:

- Logistic modeling and impact of changes of daily harvest and transport capacities on delivery and costs.

Both strategic and operational modelling will be appropriate for the Mallee Woody Crop Industry in the short term. Broad economic modelling often looks at strategic interactions but misses the technical aspects (inventory costs, delay costs, production capacity). Supply chain modelling (technical optimisation) often ignores the interaction between stakeholders and organisational aspects. Both are relevant and require all parties to look at ways to increase total value of the chain through system modelling and develop an agreed collective plan.

6.4.1 Strategic planning and modelling

Strategic planning and modelling needs to consider the following elements:

- Biomass tonnage to be delivered by each production area and farm unit.
- The length of the processing season (starting and closing dates)
- Weekly delivery allocations to ensure equitable deliveries over the season.
- Unplanned events such as processor breakdowns or delivery shortfalls, and joint rules of adjustment.

In the Mallee Woody crop industry strategic modelling has focussed on economic assessment of the commercial feasibility of woody biomass integrated with wheat production. This has provided a strategic assessment on potential for integrated Mallee/Wheat farming systems. Further detail has been given in Section 1.1 of this report.

However records on mallee plantings and biomass tonnage for delivery are basic. There are records of who planted how many mallees and in what year, but beyond that there is little detail. Locations are generally known, but survival and growth have not been assessed. Rectifying this situation and getting all the information into a GIS environment is a work in progress.

It is thus difficult to describe the mallees within 100 kms of any chosen point with confidence because the population characteristics like tonnage per site vary widely. For example about 45% of sites within 100km of Narrogin (a focus town for relatively concentrated mallee planting) are too small to sustain a single day's harvest. A large proportion of the total harvestable biomass may be present on a relatively small proportion of the sites. Sites may also fail to be economically harvestable even though they may contain significant tonnages of biomass owing to age, row layout and field condition.

A proper record of the actual harvestable resource will be an essential prerequisite for the development of a preliminary harvest plan with the usable sites scheduled for harvest according to age, tonnage and location. A modest amount of harvesting, perhaps 20-40,000 green tonnes per year could be sustained

from the existing resource, but to determine a reasonable estimate of the cost of harvesting and transporting this material should be based upon verified site data.

A regional industry harvesting plan will also enable the modelling of resource flow over the first cycle of harvest, followed by the coppice regeneration for second and subsequent harvests. Overlaid upon this will be the wave of new planting that should be stimulated by the first cycle of harvesting and biomass payments. The West Australian mallee industry has a number of problems to resolve but new plantings are still being established every year, even though at a modest rate.

6.4.2 Operational planning and modelling

Operational or Logistic models are typically used to focus on the supply of product from the field to the processing facility. In the sugar industry this has focused on reducing harvest to crush delays, improving capacity utilisation, improving scheduling to match delivery to mill crushing capacity. These models describe the path followed by a consignment of cane with the aim to pinpoint bottlenecks (Gaucher et al 2003).

Changes in the supply chain can be evaluated with a detailed description of the tasks of handling and delivering the material. Information is based on cutting, loading, transport equipment (size, number, hourly capacity, work schedule, distance, speed, downtime, etc). The approach can be used to investigate

- impact of restructuring the supply system, e.g. by closing or opening transloading centres to modify distance from fields,
- introducing new harvesting, transport and milling equipment, or
- changing delivery allocations to match the harvest capacities of growers.

In the Mallee Industry a logistics modelling approach has been adopted by McCormack et al (2009) who have modelled the cost per green tonne delivered to the mill based on various harvesting and transport options. This work highlights the operational difficulties in the Mallee Woody crop supply chain and was discussed in Section 3.2.3 of this report. Operational issues include:

- The Plant itself (Small stem size, poor presentation to harvester with multiple crooked stems and high wood density)
- Field layout (Two to four row belts, 100-200m apart with low yield of 40-80gt/ha of belt or 100-400 green tonnes per farm and long transport distances to roadside landing of 1-4km)
- Harvest/Handling issues (difficulties in pouring, tipping and handling wood chips and associated leaf and twig and low bulk density).

The logistics work undertaken by McCormack et al (2009) provides a start for conceptual logistics modelling. Chapter 7 of this report provides a comparative assessment of costs of harvest and transport of mallee based on current sugarcane harvest-haul models.

6.5 Models for Supply Chain Planning and Management - Examples for Sugarcane

In Australia sugarcane supply chain modelling, planning and management tools have looked at a range of aspects as detailed in Higgins and Archer (2005) including:

- Harvest and transport logistics.
- Business integration, information transparency and assessment of new payment formulas.
- Assessment of product diversification and new markets through co-generation.

This section provides a brief overview of these tools with some examples of their application in specific mill areas. The key message is that modelling provides a powerful tool to assess supply chain development and management, however, it needs to be site and situation specific and does not always ensure adoption for the reasons discussed in section 6.1 to 6.3.

Most research has focused on logistical opportunities, particularly in the harvesting and transport sectors which provide more challenges than other sectors. Opportunities such as harvester/siding rosters, time of window harvesting, scheduling have benefits that are easy to quantify and assess and can be adopted without extensive changes to current systems (Higgins and Archer, 2005). Non logistical opportunities have focused on increased information transparency, building new markets or business process integration.

While there have been many models developed within the Australian sugar industry they generally only consider activities or processes in a single sector (see Table 6.1). It is only relatively recently that there has been development of multi-sector models, focussing on the interface between the harvesting and transport sectors. Thorburn et al (2006) applied these modelling techniques in a participatory environment to allow groups within mill regions to more thoroughly evaluate diversification options of their sugar value chains in their region, and so move forward with more confidence and greater understanding than would have occurred with previous approaches.

Table 6.1 Examples of the processes that have been modelled within the different sectors of the Australian sugar industry (Thorburn et al 2006).

Sugarcane production	Harvesting	Transport	Milling/Factory
<ul style="list-style-type: none"> • Cane and sugar growth, responding to: <ul style="list-style-type: none"> – Nitrogen – Irrigation – Trash blanket dynamics • Statistical CCS and cane yield estimation 	<ul style="list-style-type: none"> • Harvest haul model • Harvesting group roster optimisation • Harvesting group-to-siding optimisation 	<ul style="list-style-type: none"> • Capacity planning tools for transport • Road transport schedule optimisation • Siding location and pad optimisation • Rail transport schedule optimisation and schedule checking simulation models 	<ul style="list-style-type: none"> • Raw sugar manufacture • Cane handling • Trash separation • Co-generation
<p>Underpinned by:</p> <ul style="list-style-type: none"> • GIS techniques • Database techniques for whole-of-industry models • Field and satellite information • GPS and vehicle tracking 			

Further detail on modelling approaches in the sugar industry is given below. Three case studies provide examples of the application of these models in various sugarcane mill supply regions. Further details on the case studies are provided by SRDC (2006b).

Sugarcane production modelling

Sugarcane production modeling has focused on many applications, including simulation of long term and seasonal sugarcane yields, comparing yield with and without a trash blanket, analysis of impact of soil type, irrigation and nutrient management on yield and the environment, assessment of field and row layout. The APSIM-Sugarcane model has been the basis of this work. (Keating et al (1999) and Thorburn et al (2004).

Harvest and infield haulage

Estimates of costs of harvest and haulage to loading zones or sidings were based on the Harvest-Haul model (Sandell and Prestwidge 2004). The model interacts with the Transport model by supplying harvester delivery rates and accepting time harvesters spent waiting for bin deliveries to the pad or siding. Much work has focussed on optimising the number and location of cane delivery pads in mill supply regions (Prestwidge et al 2006).

The model requires inputs for (1) the block being harvested (crop yield, block area, row length, distance to siding, allocation to siding, allocation to harvester group), and (2) the harvesting equipment (capital equipment type, size, specifications and value) in the region. GIS was used to estimate these parameters. Chapter 7 provides an assessment of Mallee harvest and infield haulage costs based on this model.

Transport systems

A road transport model has been developed by Higgins (2006) and has been used widely to for capacity planning, road and rail transport schedule optimisation and siding and pad location and optimisation (Pinkney and Everitt, 1997).

Milling/ Factory

The sugar mill model has been developed to estimate raw sugar, molasses and electricity end-products from cane supply components. A particular focus has been prediction of sugar recovery based on differing proportions of cane and trash supplied to the factory. The model is configured to include the main infrastructure of the factory, including, where appropriate, trash separation, bagasse storage, bagasse handling and electricity generation (Hobson and Wright, 2002).

Asset Management and Electronic Consignment

Tracking cane from the field to the mill in real time provides information on the volume of cane harvested, where it came from, how fast it is being cut and its route and timing of delivery. Systems have been successfully developed which provide GPS tracking on harvester, haulout and transport units, RFID tags on bins for delivery, ZigBee modems for local communication and use of NextG networks for communication of information to a central server at the mill where data is integrated into a GIS system to display real time harvest progress (Marrero et al 2010). Benefits include paperless tracking of assets and harvest/transport scheduling.

Spatial data to improve harvest management, data recording and reporting

Crossley and Markley (2011) have developed a system AgDat which integrates data and information to improve harvest management, data recording, reporting and data exchange. Field data (eg varieties, inputs, surveys) can be collected and loaded in the field and combined with data collected from loggers (eg GPS referenced harvest progress and performance) which is integrated and interpolated on a database and exchange network and made available to users through a desktop or web based interface. The system allows users to manage the production and harvest progress and interpret harvest areas from GPS tracking automatically. Farmers, extension services and advisors can record data on a spatial basis and maps can be generated or viewed. Harvest and transport integration using elements of this system has provided significant benefit to the Mackay region as indicated in a Case Study below.

Yield Monitoring and prediction

A key to supply chain management is having information on yield at a paddock and sub paddock level both prior to harvest and post-harvest. In the sugar industry post-harvest paddock level yield

information is available after delivery of the consignment based on the mill weigh-bridge records for each bin which can be assigned to a field. Within field variation is not generally available and existing sugarcane yield monitors are not of adequate accuracy and require further development and testing (Jensen et al 2010).

Yield forecasts prior to harvest are generally based on grower and cane productivity officer assessments of standing cane. Satellite imagery of area harvested as well as data derived from GPS harvester records are increasingly being used to establish areas yet to be harvested and hence tonnages remaining at stages through the season. Information on standing cane yield has also been derived by correlating canopy reflectance derived from airborne or satellite imagery with crop condition and biomass. While individual field estimates have been variable aggregation across a mill area or sub region has been shown to offer potential for production forecasting.

Benchmarking

The sugar logistics improvement program (SLIP) conducted in South Africa provides useful standards and benchmarks whereby participants can compare the performance of their delivery chain to that of others in the region. This alerts them of areas of opportunity to improve utilisation and reduce delivery times.

Case Study 6.1 – Model Application - Whole Crop Harvesting NSW Sugar Mill (SRDC 2006b)

Whole sugarcane crop harvesting to maximize cogeneration requires a substantial change to the sugar value chain. A modeling approach allows the viability of options to be assessed.

Trials have been conducted at Broadwater Mill to assess the effect of whole crop processing on sugar recovery and sugar quality. The NSW cane industry has focused on whole crop transfer to the mill to extend the bagasse supply used for co-generation. The results indicated trash in the cane supply is detrimental to both sugar recovery and sugar quality. These plans required major upgrades to harvesting and transport systems. To minimize capital costs plans were made to process the trash through the raw sugar factories as part of the cane supply thereby avoiding the need to install trash separation and preparation equipment. Studies by have shown that 20% of the total mass of the total mass delivered to the mill comes as trash, leaves and tops.

Modelling results demonstrated the complexity of interaction and site-specific nature of factors influencing the costs and revenues associated with power generation from trash in the sugar industry. The presence or absence of an existing co-generation plant with spare capacity and the cost effectiveness of bagasse storage are key issues. Harvesting and transporting the increased volume of material produced when harvesting the whole crop are also important. The logistical problems of harvesting and transporting the additional volumes of material associated with trash were not as great as expected due to identification in the study of logistical improvements in the efficiency of harvesting and transport.

Income from electricity and renewable energy certificates need to be weighed against not only the costs of constructing the co-generation facility but also costs associated with loss of trash from the field, harvesting the whole crop, transporting it to the mill, separation of cane from trash and the impact of increased extraneous matter on mill performance and sugar extraction.

Integrated modelling provided clarification on the circumstances when whole crop harvesting for maximising fuel for co-generation is most likely to be feasible. Consideration is currently being given to ways to increase the bulk density of whole crop cane (eg trash shredding and compaction) as well as requirements for trash separation plant to pre-process the whole cane and reduce trash processed through the mill.

Case Study 6.2 – Model Application - Maryborough Mill Area (SRDC 2006b)

Substantial modelling has been undertaken in the Maryborough mill area as a result of significant expansion in production up to 1999 followed by drought, disease and low sugar price.

Optimisation of harvest and transport scheduling:

Modelling aimed at reducing queue time of transport vehicles at the mill, and increasing the reliability of cane supply. It resulted in an optimisation model that demonstrated the scope for significant reductions in transport costs and queue time. **Result:** Unfortunately, unplanned events (e.g. road traffic delays, harvester delays, wet weather interruptions to harvesting) currently make model-based schedules for daylight operations difficult to implement.

Harvest scheduling to capitalise on differences in cane yield and sugarcane quality across the mill region.

This approach seeks to harvest relatively early-maturing blocks, varieties, or sub-regions earlier than in the traditional system. This allows crops to be harvested closer to their optimum time, thereby increasing per tonne returns as well as total returns from sugar production for the entire mill area. Adoption of these harvest schedules requires growers to change the order of harvest of their farm paddocks, along with the percentage of cane cut in each harvest visit. The harvester needs to change the amount of time spent on a farm, the rotation order across farms and, for regional optimisation, the harvester may need to have varying bin quotas across the season. For regional optimisation, the mill needs to modify transport schedules to accommodate changes in harvester logistics. **Result:** While some of the suggested changes were adopted, region-wide adoption did not occur. The disruption was seen to be too dramatic, and the task of gaining sufficient agreement from participants was considered to be too daunting to proceed. However, some growers with more than one farm and the Maryborough Sugar Factory on its 1,400 ha plantation have adopted the basic principles, and are reaping the benefits.

Potential for co-generation.

This required the development of the first model of the sugar industry that captured the interactions of five separate sectors — farming, harvesting, transport, milling, and marketing. In contrast with the two activities above, its thrust was to increase mill area revenue by diversifying the product range, rather than increasing production or cutting costs. **Result:** The model highlighted, in quite a dramatic way, the negative aspects of a) trash removal on the farming sector (via increased evaporation and increased costs of weed control), and b) storage of bagasse for use in the off-season (e.g. space, storage costs, and risks). When coupled with the high capital cost (e.g. for a trash separation unit, the electricity generation facility, new boilers, and other mill upgrades), it became clear that co-generation based on whole crop harvesting was not an attractive option for this region. Thus, one of the positive benefits of the project was the decision not to proceed with a major co-generation project, thereby avoiding considerable future losses

Case Study 6.3 – Model Application – Mackay Mill Area (SRDC, 2006b)

A key driver for this work was expansion in production areas up to 1999 followed by drought, disease (orange rust) and low sugar prices. Major cost cutting was required by the mill, with outsourcing of services, termination of cane inspector services, resulting in poor relations between miller and grower. A key result of this work was better cane payment systems that promote growing regional wide revenue and distribution more equitably. The project also resulted in investment in information technologies to collect store and share information to improve decision making.

Cooperative Systems Model

The mill made the decision to invest heavily in information technologies to collect, store, and communicate information electronically to growers, and involve all sectors in the decision-making process using a participative approach. Timely and relevant information about all sectors is required by participants in each sector to make decisions that support an integrated value chain. Systems have been developed to:

- record yields, paddock inputs, and pest and disease management actions;
- select varieties for use in particular blocks based on past performance on, for example, the farm, soil type, or sub-region;
- display mapping information (e.g. farm and soil maps, aerial photographs, satellite imagery, paddocks harvested, etc);
- analyse cane quality for pol, brix, fibre and ash (from which to calculate sucrose, impurities, clean fibre, dirt, and extraneous matter) by on-line NIR and provide rapid access to it (at an appropriate level of aggregation) for participants in all sectors;
- monitor harvester performance (engine on/off, elevator on/off, fan speed, and chopper pressure), track their movements by GPS, and monitor and benchmark harvesting costs using the Harvest-Haul model;
- consign cane electronically from the farm to the mill;
- benchmark all measures of performance against that of other members of the value chain; and
- store information centrally in a secure environment and provide appropriate access and application tools to all parties via a Web portal.

Many of these systems are now fully operational. The most significant outcome has been the development of a new payment system which came fully operational in 2005. It brings the interests of the grower and the miller into close alignment and pools all revenue from sugar (including sugar quality payments), electricity, molasses, and any future products before dividing it (by negotiated agreement) between miller and grower. The new system overcomes the disadvantages of the traditional cane price formula which are discussed in Section 5.3 of this report. The change to a new payment system has had an impact on the behavior of growers, harvesters and millers because it has the incentives for all parties aligned with the regional objective of “growing the size of the cake” and distributing the revenue equitably.

6.6 Supply Chain Alternatives and Options for the Mallee Industry

Based on sugar research and experience in supply chain modeling a number of recommendations for the Mallee woody crop industry are identified below. Recommendations are best interpreted and applied for a specific processing and supply area as local situations will have an overriding effect.

The focus of supply chain planning and management should be broadened from the narrow logistical and operational technical issues to include improving the transparency of information, integration of the various businesses within the supply chain, and awareness of new market opportunities.

Relationships between sectors and participants in the supply chain need to be improved. Experience in the sugar industry has shown that where there has been a tradition of cooperative relationships between participants, or a major effort has been placed to develop these relationships, there has been greater

progress in improving the supply chain, which has led to coordinated action, cooperation, and organisation among diverse industry stakeholders.

Tangible and intangible benefits of value chain improvement should be promoted throughout the industry. Tangible benefits (eg \$/ tonne biomass delivered) are sometimes difficult to quantify but provide a key incentive for adoption as does the promoting of intangible benefits (eg increased co-operation).

Flexibility should be built into the design, operation, and management of the supply chain to enable it to cope with, and adapt to, unforeseen events such as weather impacts, equipment, changes to industry participants and cross-sectoral relationships. The multi-sectoral nature of most projects meant that they are much more vulnerable to unforeseen external events than single component, single sector projects.

Consideration should be given to the development of various “model” contracts and protocols for services to encourage greater use of standard supply agreements and pricing arrangements which encourage best management practice and equitable distribution of proceeds.

While there will be potential to increase value-add through diversification, the impact on supply chain constraints needs careful consideration. A diverse range of products will strengthen mallee industry economic viability. Consideration will need to be given to the benefits and practicalities, capital requirements, and costs of production of each potential product as well as the sustainability of those markets over time. The implication of the addition of each product for the operations, productivity, and sustainability of all other sectors in the value chain need consideration.

While improved technology (such as a harvester) that will give a step change in cost efficiency should be sought, equal consideration needs to be given to integration with other elements of the supply chain and accumulated incremental improvements.

Account should be given to the social and human aspects of the supply chain. Trust will be a key ingredient for improved functioning of the value chain. Commitment should be sought to share information, improve the understanding by all participants of the drivers and operations of all sectors and increasing the size of cake as well as equitable apportionment of risks and rewards across the value chain.

Improvements to the productivity and profitability of the mallee farming systems will require further R&D to improve biomass yield, tree presentation for cost effective harvesting and better integration with other farming systems. Farming systems need to be implemented that not only enhance economic and environmental performance in the farming sector, but also match value chain requirements for overall efficiency.

Harvesting and transport systems will need to be further developed and optimised to provide improved capital utilisation and more efficient harvesting operations. This will be driven by the distribution of mallee plantings in the landscape and the specific alley or block planting configurations. Information on biomass yield, harvester and road transport performance and tracking will improve deliveries and scheduling to the processor.

A large range of supply chain models and tools have been developed and applied in the sugar sector. Key opportunities for the mallee industry include:

- Spatial mapping of mallee feedstock including age and planting arrangement to improve harvest management, reporting, mapping and data exchange.
- Monitoring of harvest progress using GPS tracking on harvesters and transport units to record area and volume of biomass removal, consignment delivery and, based on weighbridge data at the processor, paddock yield.

- Tracking of road haulage equipment based on GPS tracking to inform scheduling of deliveries and asset management.
- Harvest haul modeling of specific supply areas to optimise placement of loading zones and layout of mallee plantings.
- Refinement of mallee biomass production models to optimise farm layout and row spacing, given information on soil type, drainage and adjacent crop requirements to understand the implications of changes on both the farming and harvesting sectors.
- Broaden the scope of the models so that they encompass the entire value chain right through from biomass production, to harvesting and transport, processing and product diversification options.

7. Supply Chain Modelling and Economic Considerations

Chapter six has discussed broad supply chain planning and management issues relevant to the sugar and mallee industry. It was beyond the scope of this project to undertake a comprehensive value chain assessment for the mallee industry. A desk-top assessment of the logistics for mallee supply in Western Australia was undertaken to provide economic consideration of alternative harvest haul systems and in particular identification of key drivers and cost sensitivity. The basis for this assessment was the harvest-haul model discussed in section 6.5 (Sandell and Prestwich, 2004)

7.1 The Harvest-Haul Model

The Harvest Haul model is a deterministic model that estimates the time and cost performance of harvest at a block level and aggregates results to the farm, group and regional levels. While the model was originally developed for use in the sugar cane industry it is applicable to and has been used for a variety of harvesting operations.

Industry issues that the Harvest Haul Model has been used to investigate include:

- Modelling new projects and conducting sensitivity analyses.
- Modelling harvesting cost changes for farm re-configuration.
- Comparison of current harvesting practices to Harvest Best Practice
- Modelling harvesting cost changes for full trash collection for co-generation
- Harvest group restructure or amalgamations
- Siding or pad location re-arrangements
- Haulout optimisation within a group to determine the cost effective number of haulouts

The Harvest-Haul Model has been used extensively in the Australian sugar industry from Condong mill to Mossman mill and internationally for Fiji Sugar and Ramu Sugar in Papua New Guinea and is applicable to biomass harvesting operations.

The model estimates the time performance of harvest and applies costs on an hourly basis. Block area, tonnes, row spacing, row length, maximum ground speed and a target elevator pour rate are used to estimate the time spent cutting. The time taken to turn at the end of the row is assumed.

Time spent waiting for haul transport is estimated by assuming that the first haulout has just left the harvester. If this haulout can travel to the delivery point, unload and return in less time than the harvester can fill the remaining haul capacity then the haulout waits for the harvester. Alternatively, the harvester must wait for the haulout to return and this time is added to the total harvest time. Variables such as haul distance, haul speed, unloading time, haul capacity and number are used for this calculation.

This basic cut-turn-wait time is then increased by 6% to account for servicing (regular and scheduled), 3% for repairs (unscheduled break-downs) and 3%, 6% and 9% for moving between fields as discussed later.

7.2 Component Costs to Supply Chain

Component costs of the supply chain include capital costs and operating costs. These are represented in the model as discussed below.

Capital, unless otherwise specified, is depreciated over ten thousand hours of use. The model assumes a current capital value and a salvage value at the end of the depreciation period. Depreciation (or loss in value) costs are distributed on an hourly basis using straight line depreciation.

Annual capital finance costs are calculated by multiplying the capital value by an assumed interest rate of 8%. This cost is split into cash and non-cash using the owner's equity in the capital. Thus, if there was 25% equity in the capital equipment then 25% of the capital finance cost would be non-cash representing the opportunity cost of ownership. The remaining 75% would be a cash cost representing the actual finance cost of ownership. These costs are each distributed per hour of operation.

Overhead costs, representing registrations, insurance premiums, bank fees, accounting fees etc. are represented in one figure per annum of \$18,000. This cost is distributed per hour of operation.

It should be noted that no management costs are included in the model. Wage costs are applied at fifty dollars plus a thirty percent on-cost per person per hour.

Total fuel use is estimated for the harvester and for each haulout by applying two fuel burn rates (in litres per hour). An idle fuel burn rate is used whenever a machine is waiting or unloading and a working fuel burn rate is applied at all other times. There is no fuel consumed during servicing and repairs (but wages still apply). A cost of fuel, in dollars per litre, is assumed to derive the total cost of fuel.

Repairs and maintenance (R&M) costs have been applied at a rate of one dollar per tonne. Consumable blades are accounted for separately. Total costs are reported as gross figures and per hour, per hectare and per tonne. Harvest time performance is used to attribute costs on an hourly basis.

The model represents actual operating cost and no profit margin has been included in the model. Model component costs and the assumptions described in this section have been widely used in the sugar industry and are considered appropriate for mallee biomass harvesting.

7.3 Costing Assumptions

7.3.1 Spatial Data

Harvesting cost will be affected by field layout. Spatial data, such as block area, row length and haul distance to the nearest trafficable road were derived using Google Earth from two real plantings, one representing a high density planting and the other representing a low to medium density planting.

Haul distance was estimated by measuring the straight line distance from the paddock centroid to the nearest trafficable road and multiplying this by $\sqrt{2}$. The method assumes that rather than travelling in a straight line the haul vehicle would traverse the two shorter sides of a right isosceles triangle associated with the haul distance. This method has been used extensively and has been validated to be within 2% accuracy.

It was assumed that there was a fifty kilogram tree every two metres of row and there are two rows per belt. High, medium and low planting densities were modelled by using a belt spacing of 75, 150 and 225 metres respectively. Time spent moving from field to field was modelled as 3%, 6% and 9% respectively to represent increasing time spent moving as the planting density decreases.

7.3.2 Capital Assumptions

Three scenarios were derived, each using different capital equipment. All scenarios used:

- A harvester with a new value of \$750,000 depreciated to \$10,000 over 10,000 engine hours.
- A machinery shed valued at \$150,000 and depreciated to zero over 50,000 hours of operation.
- A service vehicle with a fuel trailer and tools at a value of \$50,000, depreciated to \$5,000 over 10,000 engine hours.

Scenario One: Rear-tip trailers

Scenario one is a low cost solution and assumes that 25 tonne capacity road-haul trailers are taken into the field and are filled directly from the harvester. These bins, represented in Figure 7.1 are hauled in field behind a tractor and, once full, are hauled to and uncoupled at the nearest trafficable road. It is assumed that the uncoupling would take fifteen minutes.

The capital value of the haul trailers are assumed to be accounted for in the road transport cost. Total system cost is \$1,377,600.00 and is detailed in Table 7.1



Figure 7.1 Rear-tip trailer

Table 7.1 Scenario one capital equipment.

Equipment description	capital value	salvage value	equity	anticipated use
	\$	\$	%	hours
mallee harvester	750,000	10,000	0	10,000
200 hp tractor	213,800	81,800	0	10,000
200 hp tractor	213,800	81,800	0	10,000
shed	150,000	0	0	50,000
service vehicle + fuel trailer	50,000	5,000	0	10,000
rear tip trailer	0	0	0	10,000
rear tip trailer	0	0	0	10,000

Scenario Two: Tipper Bins

Scenario two represents a moderate cost system and assumes dedicated 25 tonne capacity infield bins. These bins would haul to the road side and tip into the waiting road transport unit. These side tip bins would be towed behind a tractor, rather than the self-propelled unit shown in Figure 7.2, below. The advantage of this system is the dedicated infield transport units can be specialised for the conditions, with heavy duty axles, rims and tyres to better handle the adverse conditions. This scenario assumes that the 25 m³ of loaded mallee chip, which will compact and ‘settle’ into the bin due to the vibrations during filling, will be able to be tipped successfully into a 25 m³ road transport trailer.

The tipper bins are additional capital to the road transport equipment and are fully accounted for in the harvest sector. Total system cost is \$1,467,600 and is detailed in Table 7.2



Figure 7.2 Side-tip trailer

Table 7.2 Scenario two capital equipment

Equipment description	capital value	salvage value	equity	anticipated use
	\$	\$	%	hours
mallee harvester	750,000	10,000	0	10,000
200 hp tractor	213,800	81,800	0	10,000
200 hp tractor	213,800	81,800	0	10,000
shed	150,000	0	0	50,000
service vehicle + fuel trailer	50,000	5,000	0	10,000
25 tonne side tip haul out	45,000	11,250	0	10,000
25 tonne side tip haul out	45,000	11,250	0	10,000

Scenario Three: Side-tip trailers

Scenario three represents a high-efficiency high cost system that utilises modified 40-foot shipping containers and swing-lift or side-lift trailers. These 25 tonne capacity road-haul trailers are taken into the field and are filled directly from the harvester. These bins, represented in figure 7.3, are hauled in field behind a tractor and, once full, are hauled to and uncoupled at the nearest trafficable road. It is assumed that the uncoupling would take fifteen minutes.

The containers are modified so that they unload from the side and the roof is open for loading. The container pins on one side of the trailer are modified so that they can pivot. The advantage of this system is unloading time at the factory: the swing-lift is attached to only one side of the container, the side chute on the container is opened and the whole container pivots and unloads at the side. Unloading times for this system would be in the order of fifteen minutes. End-tip trailers, which need to be uncoupled for unloading and then re-coupled, have unload times in the order of one hour.

The road transport component already accounts for rear-tip trailers valued at \$86 350 each. Thus the additional value of the swing-lift trailers, \$89 650, is accounted for in the haul sector, plus the full value of two additional trailers. The total system cost is \$1,948,900 and is detailed in Table 7.3

7.3.3 Other Operating Assumptions

Elevator pour rate represents the tonnes of product flowing from the machine while it is continuously cutting. A target elevator pour rate of thirty tonnes per hour was used in all scenarios. However, this was varied in one sensitivity analysis using 10, 30, 50 and 70 tonnes per hour. These correspond, at the assumed plant yield of one 50kg tree every 2 metres, to ground speeds of 0.4, 1.2, 2.0 and 2.8 km/h respectively. Harvester cutting speed is assumed to be limited to 3 km/h.

Time to turn from one belt into another is estimated using the belt spacing and a tractor acceleration of 0.01 m/s^2 and a maximum ground speed of 25 km/h. Harvesting is assumed to occur in a circuit pattern.

It is assumed that two haulouts of twenty-five tonnes capacity are used in all scenarios.

Fuel Burn rates, in litres per hour, are included in Figure 7.4. Fuel is costed at \$1.40 per litre, which is exclusive of on-road tax.



Figure 7.3 Swing-lift containers

Table 7.3 Scenario three capital equipment

Equipment description	capital value	salvage value	equity	anticipated use
	\$	\$	%	hours
mallee harvester	750,000	10,000	0	10,000
200 hp tractor	213,800	81,800	0	10,000
200 hp tractor	213,800	81,800	0	10,000
shed	150,000	0	0	50,000
service vehicle + fuel trailer	50,000	5,000	0	10,000
33 tonne side lift trailer - additional value	89,650	25,469	0	10,000
33 tonne side lift trailer - additional value	89,650	25,469	0	10,000
33 tonne side lift trailer - full value	176,000	50,000	0	10,000
33 tonne side lift trailer - full value	176,000	50,000	0	10,000
modified shipping container	10,000	0	0	10,000
modified shipping container	10,000	0	0	10,000
modified shipping container	10,000	0	0	10,000
modified shipping container	10,000	0	0	10,000

Table 7.4 Fuel burn rates

harvester fuel burnt rate at idle	29	Litres per hour
harvester fuel burnt rate at work	86	Litres per hour
haulout fuel burnt rate at idle	8	Litres per hour
haulout fuel burnt rate at work	24	Litres per hour
vehicle fuel use per day	15	Litres per day

Wages are calculated at \$50.00 per hour flat rate with a 30% on-cost. This is to reflect the typical rate for this area where operators will typically travel from Perth and work on a three or four day shift.

Feed mills and processing plants typically operate for around 8,000 hours per year. This equates to 334 days per year of operation at 24 hours per day. Some harvest scenarios return a few hours of harvest per day. In reality, one would operate on a roster of one day on and two off, for example, to bring the harvest hours per day to a more realistic number of hours per day. The model, for the sake of comparison, has assumed that harvest activity occurs each of the 334 days per year and has allowed the harvest hours per day to vary. Some scenarios return at around seventeen hours per day. Obviously this would occur in two shifts plus a rostered day off as appropriate and again this has remained as one shift for 334 days per year. Varying the rostered days on and off will have no effect on costs. Some of the largest group sizes at very low pour rates return a harvest duration of more than twenty-four hours per day. Clearly two harvesters would be required for this. Again, harvest hours per day has been allowed to vary for the sake of comparison.

7.3.4 Road Transport Assumptions

Road transport costs are in addition to harvest costs. Previous modelling has suggested two prices for road transport: \$0.13 per tonne per kilometre and \$0.17 per tonne per kilometre. Both rates assume that trailers are hauled in pairs.

Bulk density trials are currently underway. The modelling has assumed that bulk density is adequate to achieve legal axle loads, which seems likely from work to date and from experience in the wood chip industry. Scenarios One and Three are more likely to achieve higher bulk density as the bins are filled directly by the harvester so that packing of the wood chip occurs during filling. Scenario Two, where infield tipper bins tip into road transport, is more likely to be affected by bulk density issues and assumes that the wood chip can be tipped from bin to bin without decrease in bulk density.

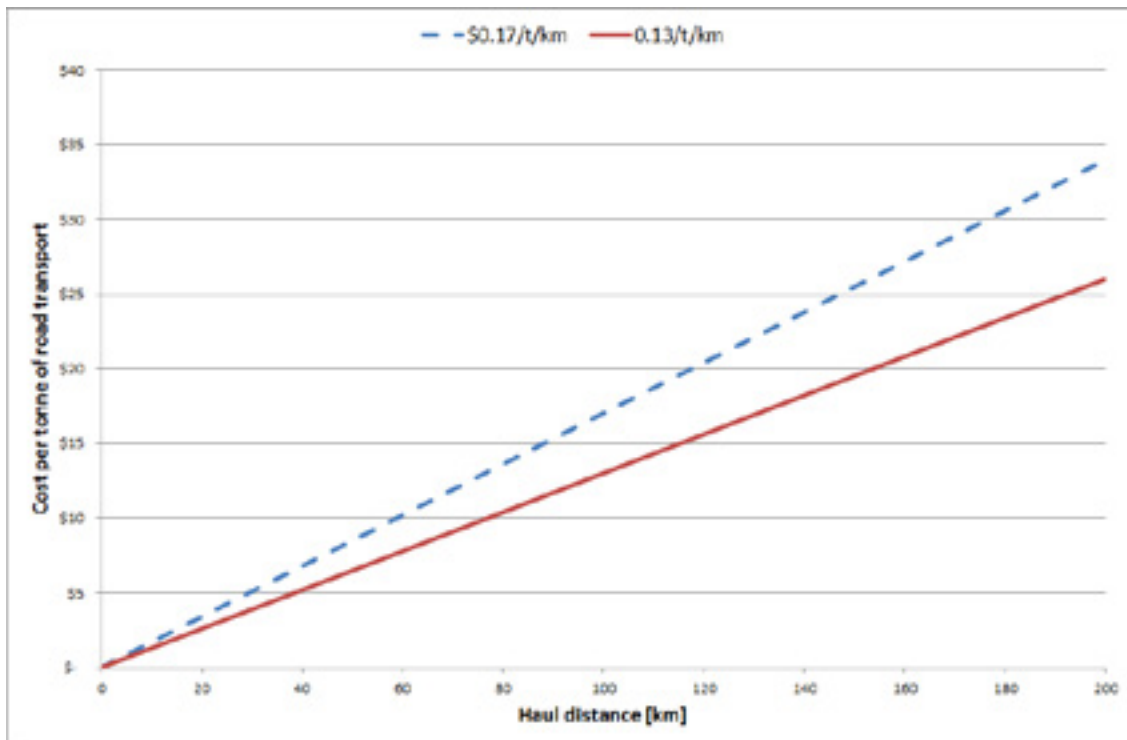

Figure 7.4 Impact of haulage distance on road transport costs.

There are some differences in the cost of road transport that are outside the scope of this modelling: Scenarios One and Two, where the wood chip is transported to the factory in end-tip trailers is likely to be most accurately reflected with the cost assumptions. Scenario Three, with the swing-lift trailers, have a much faster unload time at the factory; fifteen minutes compared to one hour for the tipper bins. While this will reduce the cost of transport it is offset by the lower tare weight due to the weight of the swing lift.

7.3.5 Factory Assumptions

There are some capital requirements at the factory to handle the wood chip and feed it into the boiler. These would typically include a hard stand area, a front-end loader and a conveyer/feed mechanism. A ball park figure might be around one million dollars for this equipment. Running costs of the loader, if assumed to be similar to a sugar cane harvester, might be in the order of \$3.00 to \$4.00 per tonne. These are not costed into the modelling.

7.4 Sensitivity Analyses

A series of sensitivity analyses was undertaken. The base case was Scenario Two (moderate capital cost system with tipper bins) for a 20 MW plant (144,000 green tonnes) at an elevator pour rate of 30 green tonnes per hour in the high density scenario (belt spacing of 75 m). The results of these sensitivity analyses are given below.

7.4.1 Capital Costs

The impact of infield (harvester and haulout) equipment on harvesting costs is illustrated in Figure 7.5 below. Capital cost has some impact on the cost of harvest but is not significant. The selection of capital equipment is important as it can bring inherent efficiencies. It is also important that infield equipment is suited to the adverse conditions found in mallee harvesting.

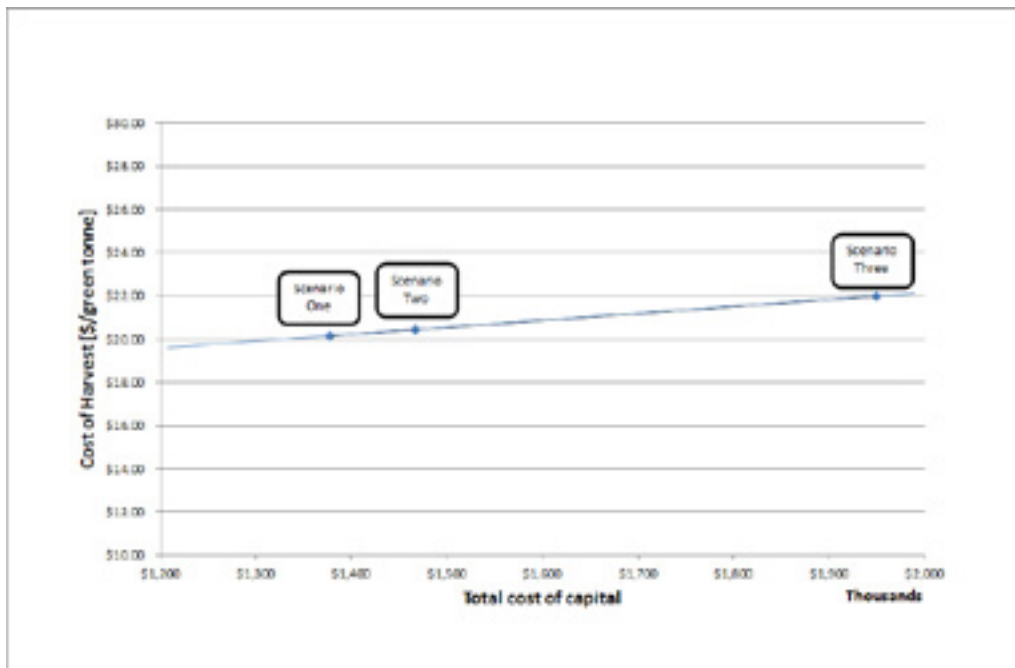

Figure 7.5 Effect of capital equipment selection and cost on harvesting cost.

7.4.2 Belt Spacing and Planting Density

The same spatial data was used throughout for consistency and the belt spacing was varied by using a belt spacing of 75, 150 and 225 metres to represent high, medium and low planting densities respectively. This resulted in yields of 6.4, 3.2 and 2.1 green tonnes per paddock hectare respectively. Time spent moving from field to field was modelled as 3%, 6% and 9% respectively to represent increasing time spent moving as the planting density decreases. The effect of belt spacing on harvest cost is shown in Figure 7.6 to be limited. This is primarily due to the large proportion of time the harvester spends chipping in the row relative to the time spent moving between field and rows.

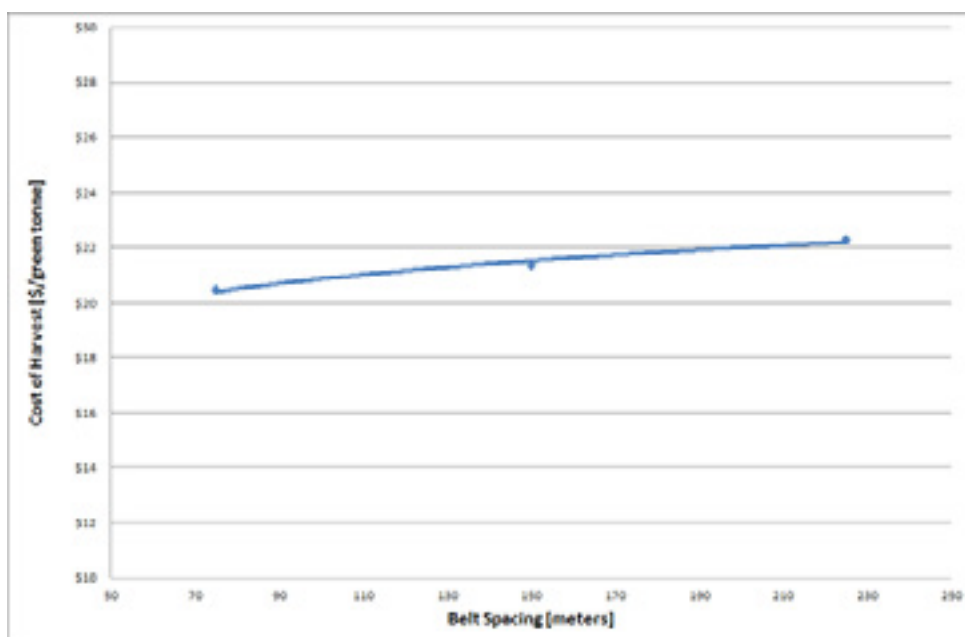

Figure 7.6 Effect of belt spacing on cost of harvest

7.4.3 Annual Tonnage Harvested and Harvest Pour Rate.

The impact of scale of industry was represented by assessing various annual tonnage harvested. This was selected to represent a range of potential electricity generator sizes, namely 2, 8, 14 and 20 Megawatts. It was assumed that 7,200 green tonnes will provide one megawatt of power.

Harvester pour rate is defined as the green tonnes per hour delivered from the harvester while it is continuously harvesting. Harvester pour rates between 10 tonnes/hr and 70 tonnes/hr were assessed. Currently harvester pour rates of around 30tonnes/hr are being achieved with the prototype harvester.

The combined effect of tonnes harvested and harvester pour rate is detailed in figures 7.7, 7.8 and 7.9. Note that at the lowest pour rate of 10 green tonnes per hour, the 14 and 20 megawatt scenarios (100,800 and 144,000 green tonnes respectively) are not physically achievable with one harvester, as harvest durations would exceed 24 hours (Table 7.11). The 14 MW at 10 green tonnes/hr scenario would require two harvesters and the 20 MW at 10 green tonnes/hr scenario would require three harvesters. Thus, these two cost points are not accurate and are included for completeness only. However, it would be safe to assume that these costs could be doubled and tripled respectively.

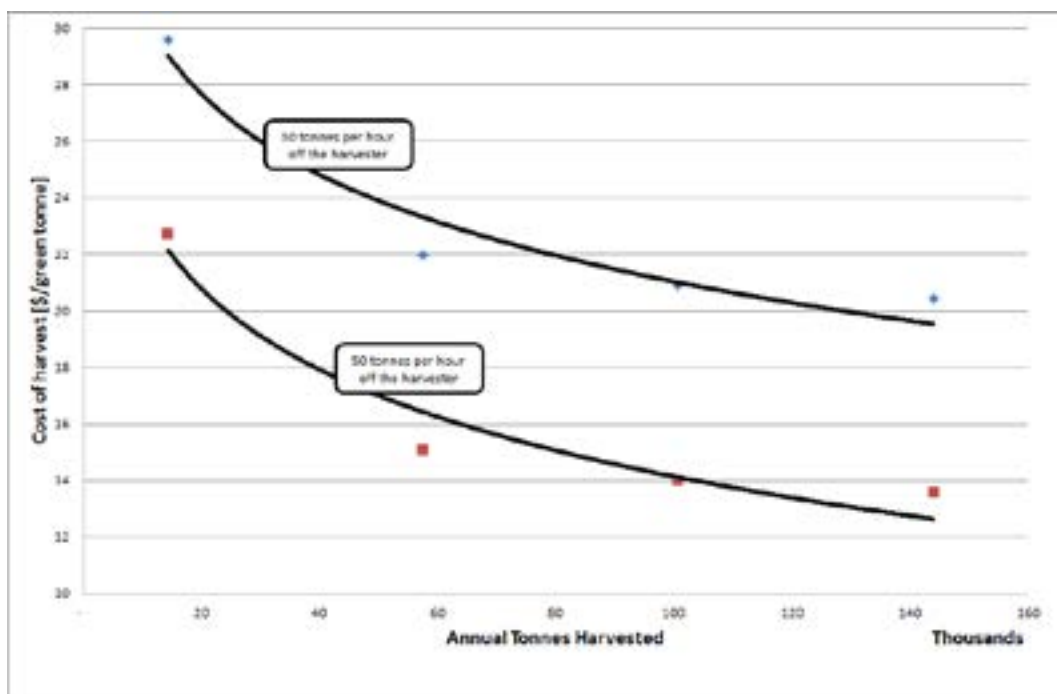

Figure 7.7 Effect of annual tonnes harvested on harvesting cost

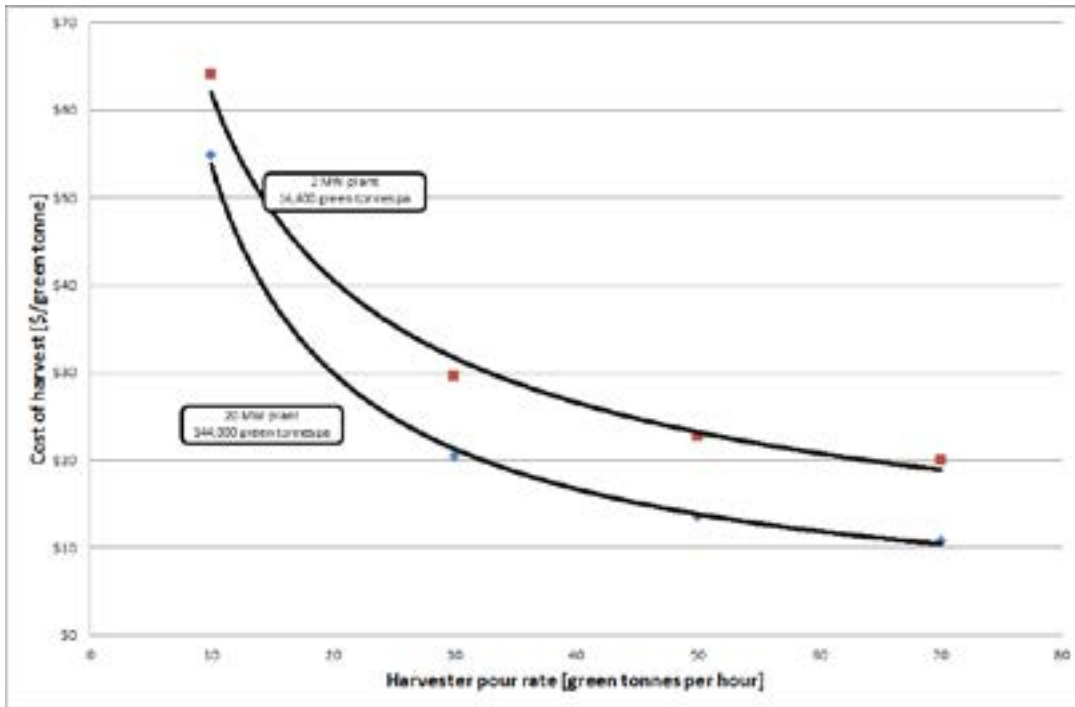

Figure 7.8 Effect harvester pour rate on harvesting cost

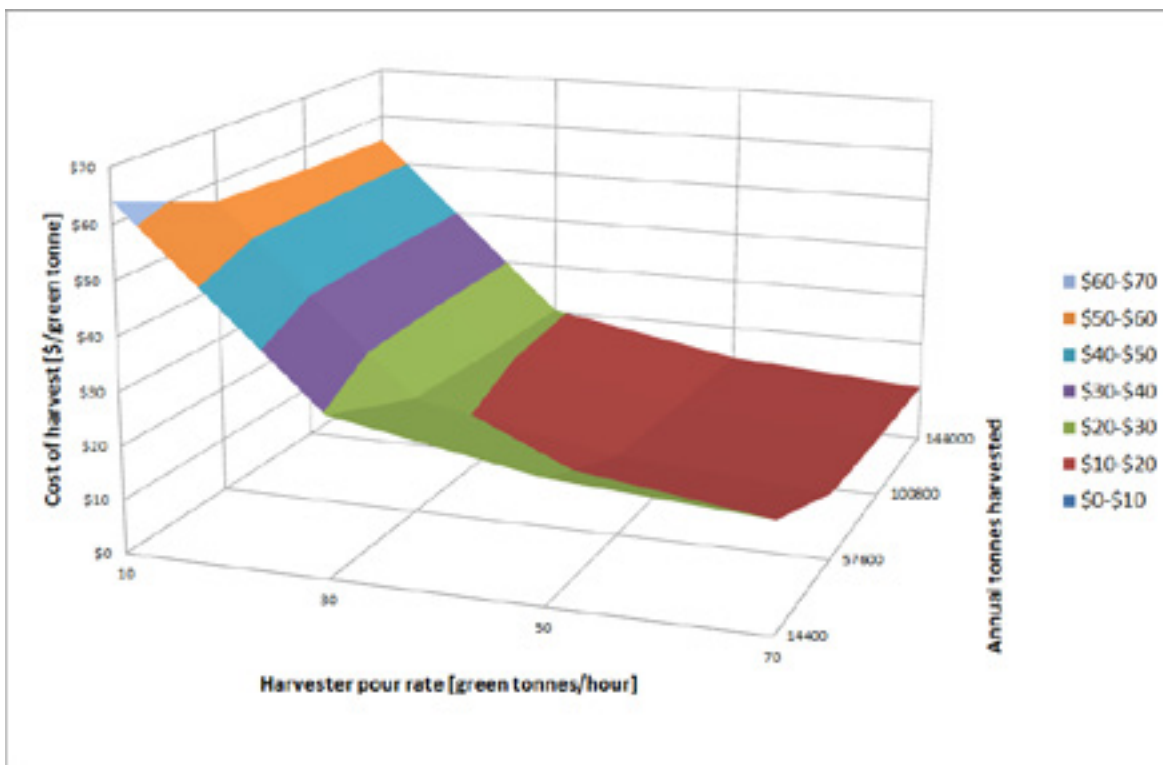

Figure 7.9 Effect of harvester pour rate and annual tonnes harvested on the cost of harvest

Table 7.5 Data table of the effect of harvester pour rate and annual tonnes on the cost of harvest

Cost of harvest [\$/t]	Annual tonnes harvested			
	14,400	57,600	100,800	144,000
Harv. Pour rate [t/h] 10	64.08	56.45	55.36	54.92
30	29.60	21.97	20.89	20.45
50	22.71	15.08	13.99	13.55
70	19.99	12.36	11.27	10.84

Table 7.6 Effect of harvester pour rate and annual tonnes harvested on shift length.

Shift length [hrs per day]	Annual tonnes harvested			
	14,400	57,600	100,800	144,000
Harv. Pour rate [t/h] 10	5.1	20.4	35.6 ¹	50.9 ¹
30	1.8	7.0	12.3	17.5
50	1.1	4.3	7.6	10.8
70	0.8	3.3	5.8	8.2

¹ Two or three harvesters required

7.5 Conclusion and Recommendations

A desktop assessment of mallee harvest haul logistics has been undertaken for Western Australian alley plantings. The modelling was based on the approach widely used in the sugar industry (Sandell and Prestwich, 2004).

The analysis indicates that harvester pour rate has the largest impact on the cost of harvest. High pour rates equate to more income for each unit of fuel, wages and all other costs.

Tonnes harvested per season also have a large effect on the cost of harvest. Higher annual tonnes equate to better capital utilisation.

Road haul distance has the next largest effect on cost of harvest: - the further the wood chip is carted, the more it costs. With haul distances of 100km haulage costs are likely to be around \$15/green tonne.

Capital cost has some impact on the cost of harvest but is less critical. The selection of capital equipment is important as it can bring inherent efficiencies. It is also important that in-field equipment be suited to the adverse conditions found in mallee harvesting.

Row spacing has a small impact on the cost of harvest because the harvester spends most of the time harvesting due to relatively low ground speeds and large row lengths.

For small scale industry development (14,400 green tonnes/yr of biomass chip delivery which is equivalent to a 2MW power generation capacity) and current prototype harvester performance (30 green tonnes/hr pour rate) harvesting costs are shown to be around \$29.60/green tonne. Combined with road haulage costs of \$15/green tonne this would equate to a delivered cost to a processor of \$44.6/green tonne. To this one would need to add a return to the grower (stumpage cost). This needs to be compared against the value of product to the processor and the fee the processor is prepared to pay. A harvester would be underutilised under this scenario.

For large scale industry development (144,000 green tonnes/yr of wood chip delivery which is equivalent to a 20MW power generation capacity) and future harvester performance (50t/hr pour rate) harvesting costs are shown to be around \$13.50/green tonne. Combined with road haulage costs of \$15/green tonne this would equate to a delivered cost to a processor of \$28.50/green tonne. This would provide a more appropriate cost of supply when compared with the fee the processor is likely to be prepared to pay. A harvester would be required to work an average 11 hours per day to process this tonnage.

Table 7.7 compares likely harvesting costs of alley based mallee systems in Western Australia to whole crop sugar systems in NSW. Sugarcane systems have a much lower harvesting cost (\$6.40/green tonne) based on the large scale of the industry (good capital utilisation), high crop yields (170t/ha) and high delivery rates. Despite higher harvester field efficiency rates under mallee systems (owing to the large proportion of time spent cutting in the row) the delivery rate to the road haulage vehicle is relatively low. This results in a high harvest cost which is approximately twice that for whole crop sugarcane harvesting even under the “future” scenario of mallee harvester development and industry size.

A key requirement for mallee supply chain development will be improvements to field layout and mallee plant presentation and to harvester design capacity to allow high pour rates of 50t/hr.

Table 7.7 Comparison of Mallee (Western Australia) and Sugarcane (Whole crop - NSW) harvesting costs

	Sugar NSW	Mallee	
	Whole Crop	Present 2MW 30t/hr	Future? 20MW 50t/hr
Biomass (Tonnes)	1,263,063	14,400	144,000
Yield (t/ha)	170	6.4	6.4
Pour rate (t/hr)	134	30	50
Delivery rate (t/hr)	67	25	40
Harvester Field Efficiency (%)	50	82	79
Harvest Cost (\$/t)	6.44	29.6	13.55

8. Conclusions and Recommendations

Sugarcane and mallee systems have many similarities. They both represent high volume, relatively low value crops, which require considerable processing and value addition to meet the selected market. Both systems have significant harvest and transport requirements using specialised equipment. In both cases delivered cost is high relative to the market price.

Sugarcane industries have spent many years researching and refining their crop production systems and associated harvesting and transport arrangements. While sugarcane farming systems have evolved to meet a specific market, the mallee woody crop industry has yet to define its market.

Innovation in sugarcane farming has been largely driven by growers of a monoculture crop aiming to meet a specific product requirement. Mallee growers in Western Australia have had multiple objectives under integrated wheat and mallee cropping systems. They have only recently started to consider mallee markets and harvest and transport costs. Elsewhere, such as NSW, mallee is being considered solely as a biomass resource and systems are being developed by Aurora Research and Delta Electricity to optimise production and the supply chain as a viable standalone business.

The key issues and recommendations provided in this report will assist all participants in realising a sustainable supply chain. An important next step will be implementation of appropriate recommendations to support implementation of a regional biomass supply chain. Opportunities for this include Narrogin (Western Australia), NSW as part of the Delta/Aurora research biomass project and Northern NSW as part of the NSW Sugar Milling cooperatives cogeneration initiative.

Crop Production

Chapter 1 of this report has contrasted the sugarcane and mallee crop production systems. The sugar industry has over time been able to modify its farming systems to maximise crop production and adapt harvesting and transport systems to minimise damage to the field and plant while improving the quality of the delivered product. It has also implemented harvesting best management practices which address harvest and transport requirements as well as crop agronomic requirements. The mallee industry has also been researching these issues which will require ongoing implementation, monitoring and review as the commercial aspects of the industry mature.

The sugar industry has placed considerable effort getting a better understanding of and managing the various components of the harvested crop and its impact on transport and sugar processor arrangements. This area has received limited consideration in mallee systems. It will become a critical issue if markets for biomass have strict quality requirements and if efficiencies of harvesting, storage and transport systems are compromised.

Expansion in the sugar industry has generally been driven at a local mill area scale in response to market forces. Future expansion in mallee production will be driven by the market for biomass and farming systems and layouts will need to adapt to the economics of this supply arrangement.

Sophisticated information and data collection systems have developed in the sugar industry to manage supply areas and volumes. These systems are generally coordinated by the processor to ensure a stable supply chain and include GIS information on field area, daily cane deliveries (quantity and quality), GPS tracking of harvesting and transport units to coordinate scheduling and integrated information systems allowing real time communication to all in the supply chain. These systems are mature and could be readily customised for biomass industries.

A sustainable mallee woody crop industry will require optimised farming and delivery systems. This may comprise mallee biomass supply on its own, or mallee integrated with other farming systems.

Optimum planting and management arrangements will differ markedly for each scenario. Competition for soil moisture is important and will depend on local climate and soils. Row layout, tree spacing and age at harvest will impact harvesting efficiency. Since harvesting and transport will be the major cost in mallee supply to the processor, designing the layout to maximise harvest efficiency and minimise cost is of critical import.

Considerable capital has already been expended on establishing more than 13 000 Ha of mallee in Western Australia. Many of these alley plantings will be too old to harvest economically with a chipper harvester and alternative systems (e.g. feller-buncher) will be needed to control competition with existing cereal crops.

It is likely that biomass supply to a processor will comprise block plantings close to the processor, supplemented by existing feedstock from dispersed alley plantings where appropriate. Block cultivation may comprise closely spaced alleys (10-30m) on marginal land close to the processor. Spacing will be site specific and determined by soil moisture competition and yield. Harvest and transport logistics must be considered in determining layouts. Harvesting efficiency will be improved when the concentration of biomass per metre of row is maximised and distance between belts is minimised.

Where mallee planting is not intended for biomass removal, consideration will need to be given to protocols for carbon credits.

Mallee planting provides vegetative biodiversity in a wheat monoculture and the collateral benefits of this biodiversity and associated environmental dividend needs to be quantified.

Improvements to the productivity and profitability of the mallee farming systems will require further R&D to improve biomass yield, tree presentation for cost effective harvesting and better integration with other farming systems. Farming systems need to be implemented that not only enhance economic and environmental performance in the farming sector, but also match value chain requirements for overall efficiency.

Harvesting Systems

Chapter 2 demonstrated that sugarcane harvesting and transport systems have many similarities with mallee systems. In particular whole-of-crop sugarcane harvesting with all material (cane and trash) transported to the sugar mill has close synergies with mallee harvesting system.

The sugar industry has shown the importance of considering whole-of-system performance to ensure components of the supply chain work efficiently as an integrated system. The prototype mallee harvester provides an opportunity to evaluate machine performance and assess critical parameters across the supply chain.

The current harvester performs the basic functions of gathering, severing stems at ground level, feeding all the woody and leafy biomass through a chipper system and delivering the chipped product into infield transport. There is no debarking or separation of leafy biomass from woody biomass during the process. The current system is limited by available power which impacts pour rate, a critical factor in the delivered biomass cost and future prototypes will need to address this. Manoeuvrability, mobility and associated soil compaction issues will need to be considered in the selection of the tracked or wheeled configuration harvester.

The prototype harvester, in trials to date, has achieved a pour rate of up to 38t/hr for a short period. A continuous machine pour rate greater than 50 t/hr will be required for a viable harvesting system.

Biomass bulk density has a large impact on transport system performance. Bulk density changes with tipping and transport, and the associated impact on product handling has not been determined for

mallee material. Similarly, the effect of product composition (chip, leaf, twigs) on bulk density will be important although the influence on biomass composition appears to be minor. However the quality of the chipping process – the quality of cut – could potentially have a significant impact upon material handling properties, and possibly some influence upon bulk density.

There are significant losses from mechanical harvesting of sugarcane during chopping of billets and separation of trash. There is no quantitative data on mallee harvesting losses but preliminary observations suggest they should be low since there is no separation of the product on the harvester.

Transport efficiencies may be improved by leaving residue materials such as bark and twigs behind in the paddock, however separation on the harvester has a low chance of success and will result in a more complex machine design and product losses in field. Given sufficient value for residues, for example as a bioenergy feedstock, transporting the mixed biomass will be the best option. Use of semi-mobile equipment to undertake product separation at nodes close to the biomass source and then transport of different products to different markets would be an option.

Sugarcane harvester field efficiencies are typically 50%, whereas for mallee, modelling indicates field efficiencies could be 70-80%. This is the consequence of long row lengths and slow harvesting speed, resulting in a reduced number of times the harvester needs to turn per hour of operation and per tonne harvested.

The dispersed nature of the mallee crop will have a significant effect upon field efficiency, with yields per paddock hectare of less than five green tonnes per hectare, and typically around one green tonne per hectare. In-field haul distances will be relatively long and vary widely over short periods, which will make the logistics of harvesting and hauling complex. To simplify this part of the process, the introduction of a shunt truck between the haulouts and the road transport is under consideration, as it should allow the harvester and its associated haulouts to work closely together and introduce important flexibility into the farm operations.

Harvest timing is restricted to the winter and spring seasons in Australian sugar cane, whereas mallees could, with some qualifications, be harvested all year. This changes the scale of operations significantly, in that a one million tonne per season sugar mill processes at the rate of about two million tonnes a year. In comparison, a large bioenergy conversion factory might require about 100,000 to 200,000 green tonnes of biomass over a whole year. While mallee road transport logistics will consequently be relatively simple, the dispersed mallee crop and long in-field transport distances will make on-farm logistics relatively complex and expensive. Extensive use of sugar cane logistics and harvester monitoring systems will help the new mallee industry.

The mallee industry will also benefit from the comparatively stable nature of the harvester delivered product. Green biomass can be stored for periods of a few days, and after upgrading and drying the finer components of the biomass, storage for a number of weeks should be feasible. This is a significant point of difference with sugar cane, which has cut-to-crush intervals of only hours, which makes the logistics of a mill's supply chain complex.

Payment systems and business structures vary in sugar cane and provide a range of models from which a new mallee industry will be able to choose. The new industry has the opportunity to set itself up so that responsibilities and rewards are properly aligned and the value added along the supply chain can be appropriately shared amongst the participants – to increase the size of the cake for the benefit of all.

At equivalent pour rates, the cost of sugarcane harvesting is less than half that of the estimated cost of mallee harvesting. The actual cost of mallee harvesting is unknown but modelling a hypothetical system has demonstrated the importance of pour rate and tonnes per harvester per year in reducing per tonne costs. The high power requirement for mallee chipping and the low speed at which harvesters can travel while cutting trees will limit the capacity of the new industry to reduce per-tonne costs.

Increasing harvester performance will be critical to reduce harvesting costs. Key information that should be collected when the harvester commences full scale infield trials in order to inform decisions on improved harvesting systems includes data on material bulk density and whole-of-system performance. Information on losses which will include leaves, branches and twigs expelled during felling and feeding should be evaluated and quantified.

Consideration will need to be given to appropriate tipping and pouring options. Harvester and chipper design could be impacted in terms of chip size and the trade-off between chipping costs (chip size) and transport costs (packing and bulk density).

Consideration will need to be given to factors relating to crop configuration that will improve pour rates and efficiencies. This could inform changes to the mallee row arrangement to better suit commercial harvester and transport constraints. Harvester operation and production appears optimised if mallees are close together (<2m spacing) in 3m spaced rows.

Further work on supply chain analysis and logistics is recommended to ensure that the scale of the supply chain components is appropriate and work efficiently as an integrated system. The mallee industry can draw on the experiences and lessons from the sugar industry in respect to capacity planning, scheduling and harvesting payment structures.

Transport and Storage Systems

Infield transport is an important part of the supply chain and has been shown to be one of the major components in the delivered cost of other biomass supply chains. Similarly, road transport will have a significant impact on the delivered cost.

The transport systems will be impacted by the nature of the material to be delivered (e.g. wood chip vs. whole tree biomass with leaf material) which is impacted by the biomass market. Mallee biomass will be more difficult to move, tip and transport than other biomass products such as grain, clean wood chip and cane billets.

The chipped biomass must be moved from the farm to a centralised receiving point for transfer to road transport. The chipped biomass will be thrown directly from the harvester to a following bulk bin (haulout) which will forward the material to the field edge. A shunt transport unit will then move the biomass to the receiving point for the road transport. Due to the cost of reclaiming heaps on the ground, it is unlikely that chipped biomass will be stored on farm.

The dispersed layout of the mallee crops creates significant challenges for cost-efficient transport of biomass from the harvester to the road transport receiving point. A lack of real crop distribution data limits the usefulness of system analysis data. In-field transport distances will vary widely over short periods of time, so transport to the roadside landings will require a two-stage process to give the operation the flexibility to cope with widely varying harvester-to-landing distances. Haulouts will need to have high capacities because they represent the smallest batch process in the supply chain.

Mallee is spread geographically across the Western Australian wheat belt and harvesting will be a year round operation, so soil conditions will vary widely, both spatially and over time. The Mediterranean climatic conditions can see unstable soils become commonplace during winter.

Vehicles used for infield haulout will need to be suitable for off-road use and have low ground pressures. Depending on the row configuration and if low stumps are left by the harvester, rubber tracks or low floatation tyres will need to be considered.

Consideration could be given to pre-processing at roadside landings, involving upgrading processes such as chip separation, oil distillation, drying and even pellet manufacture. This would improve the marketing of the biomass, by placing the emphasis of the long-haul road transport upon the movement

of specific value-added products to appropriate markets. However costs and efficiencies of the several options would need to be assessed.

The need for and role of material stockpiles will need to be evaluated in terms of the supply chain management and impact on product quality. Stockpiles are a risk management strategy and can ensure continuous feedstock supply in case of interruptions (for example fire, flood, soft soils, and major mechanical breakdowns).

The grain transport trailers that are common in the wheat belt regions do not have the volumetric capacity for biomass. The wood chip transport systems are geographically somewhat distant from mallee areas and they rely, partly for historical reasons, upon the use or rear discharge by tipping or walking floors. This requires that road trains be decoupled and reassembled for every load, which imposes extra cost upon woodchip transport compared grain transport, which can empty trucks through a grizzly screen. The mallee industry will have the opportunity to avoid this problem if it adopts side loading and unloading from the outset. If the materials handling process from the point of harvest is containerised, then side loading and unloading can be accommodated using the principles of sea container swing-lift technology.

The nature of the biomass material to be delivered needs to be well defined to allow the most suitable transport system to be developed. Appropriate strategies will need to be developed for transport configurations such that the bulk density of material is not reduced.

Existing and potential haulout and road transport systems have been reviewed but conceptual designs of the alternative new systems need to be developed and proper financial analysis conducted. Comparisons of existing and potential systems need to be thorough and systematic.

A resource inventory of the existing mallee in Western Australia is essential for proper analysis of alternative transport systems and development of the early commercial operations. It will also assist in planning and guiding future expansion of the mallee resource so as to maximise transport efficiency.

Products, processing and impacts on supply chain

The development of a viable industry based on oil mallee cannot happen “overnight”, however analysis of the potential for downstream products to support a large scale industry is promising.

The industry cannot, however, develop on the back of current products such as the boutique oil industry. The magnitude of the potential supply will overwhelm the current market. Extracted oil is seen as an important potential product, but as an industrial product, and as a strategy to value add the leaf material. At the projected prices, it is not a viable product in its own right.

Similarly, a number of small-scale options exist which can offer very attractive markets for limited production quantities. Such markets include thermal energy for abattoirs and feedmilling, and the generation of electricity for use on-site. The former displaces LPG and diesel as heat sources, and the latter displaces local diesel fuelled systems, or perhaps when used on-site as an alternative to retail electricity purchased off the grid. When combined thermal plus electrical energy may be generated more efficiently from the biomass. Both these will remain as markets, but are limited in size. Significantly, technologies such as combined heat and power and the technology development to incorporate harvested mallee as a feedstock will be important pre-cursors for the technologies for a larger scale industry.

As the Industry expands, the most significant potential markets will probably involve emerging technologies such as liquid fuels via pyrolysis. On the basis of current information, this market is seen as offering good returns, with the technology being appropriate for major regional centres, thus managing transport costs. Initial processing and oil extraction would be undertaken at nodal points, with value added product forwarded to the major centres.

Whilst co-firing of coal fired power stations with mallee is potentially a very large market which could nominally consume the entire projected annual harvest, the location of coal fired power stations relative to mallee production areas means that co-firing will not be a major market for the bulk of the projected industry, because of transport costs.

Products such as metallurgical charcoal and bio-char are potentially significant products, but of lower value, and unlikely to drive major industry expansion unless costs of harvest and transport were significantly reduced relative to projected levels.

The development of a long term viable project can be driven by actively targeting small but potentially highly profitable niche markets in the short term and supporting these to further develop the technology envisaged for a larger scale industry.

Apart from local thermal and electricity, higher value uses of mallee will require significant transport and some storage. The leaf and twig material are of lower density and deteriorate more rapidly than chipped wood material. They are of some potential value for oil extraction and after oil extraction this material is of similar value to woodchip for many potential uses.

A high level of extraction of leaf material is desirable to maximise the value of woodchip for a number of potential uses. Using current or envisaged technology, the product off the harvester would not meet envisaged standards for many applications because of the mix of components.

A potential strategy for expanding the industry could comprise:

- Harvest the mallee trees utilising short haul transport concepts to transport the product 20-30 km from farms to nodal processing sites.
- The nodal processing sites would have the appropriate re-locatable or semi-mobile equipment to separate leaf, twig and bark material from the chipped wood.
- The woodchip would be transported directly via rail or road to appropriate processing facilities such as synthetic diesel production.
- Mallee oil would be extracted utilising relatively low technology steam extraction at the nodal processing site. The extracted leaf could be sun-dried utilising low tech strategies such as shallow bed drying. The dried leaf could then be utilised for a number of potential uses, including baling for lower cost of transport to higher value potential uses and local use for local thermal or electricity production.

Preliminary analysis of potential mallee products, including the feedstock component, product value and extraction costs, suggests that fresh weight values in the order of \$100/green tonne could be achievable for large scale oil extraction combined with metallurgical charcoal and synthesised diesel.

Similarly for a limited local industry comprising oil extraction combined with local electricity and thermal heat, fresh weight tree value could be in the order of \$185/green tonne. These costs do not include a processing profit margin.

This can be compared with harvest and haul costs (excluding contractor profits) of around \$45/green tonne (based on small scale production of 15,000 tonnes/yr, low harvester performance, pour rates of 30tonnes/hr, and a 100km haul) and \$28/green tonne (based on large scale production (145,000tonnes/yr and high harvester performance, pour rate of 50tonnes/hr, and a 100km haul).

Stumpage charges for the grower to recover biomass production cost would need to be added and could vary from \$15-\$30/green tonne.

Apart from continuing development of harvesting technology, the components in a model of a full scale industry must be further developed. This will involve further analysis of potential product streams and the opportunities for maximising the synergies from the production of different products.

Whilst further development of the overall industry model is required, a number of enabling technologies will almost certainly be required to be developed and optimised. It is probable that the technologies will include:

- Efficient separation of “ex harvester” product into components, primarily leaf, twig and bark from the woodchip component.
- Efficient steam extraction of the leaf and twig components, versus the current strategies of whole tree product. This will be essential to reduce the energy consumption and cost associated with oil extraction.
- Efficient drying and densification of leaf and twig material after oil extraction to maximise transport densities and minimise transport costs.
- Automated combustion systems for mallee chip and densified leaf product.

In addition to these basic components, it is essential that work continue on the “Big Picture” components of the potential industry, including gasification/pyrolysis for the potential production of liquid fuels.

Industry and Business Structures

Chapter 5 has outlined the various industry and business structures in the sugar industry. Organisational structures and how costs and profits are divided across the mallee biomass supply chain will be crucial to provide incentives for efficiency improvement.

Within the sugar industry costs (e.g. harvesting) are generally averaged across participants and individuals are not always aware of their costs or rewarded for efficiency. The sugar industry has recognised that streamlining the value chain is essential to ensure optimal mill throughput and a reliable cane supply, and that sustainability will be improved by identifying and targeting real costs. Other mechanisms to ensure supply reliability have included long term contracts and performance based incentives.

Harvest and transport represents 30% of costs within the sugar value chain and there are significant inefficiencies which are principally a result of divided responsibilities between the grower and the miller. The cost of harvesting is the grower’s responsibility while the cost of transport is the responsibility of the mill. Across some regions within the sugar industry a reduction in the number of harvesting operations and optimising existing groups are demonstrating some benefits.

Institutional and regulatory arrangements have had a profound impact on development of the sugar supply chain. In particular, development of a cane payment formula that accounts for quality of cane delivered has been significant in improving supply chain performance. Pricing arrangements are now negotiated regionally based on an industry framework. In the mallee industry, particularly when there are multiple products and markets, appropriate payment mechanisms need to be considered.

The sugar industry has a number of ownership models. Generally the greater the proportion of the supply chain owned by a single entity (eg a cooperative) the greater the efficiency and lower the conflict. Good performance across the value chain also results when there is cooperation and commitment between each sector in sharing business proceeds.

Ideally the harvest and transport system would be more readily optimised if owned by a single party managing the process from plant in the field to biomass delivered to the mill. In practice the harvest and transport system of the sugar industry involves multiple combinations of ownership including

farmers (hundreds), contract harvesters (several to many), contract truck transport and the sugar mill. Harvest and transport systems are recognised as a priority for quantum gains in productivity.

To achieve a sustainable biomass industry, the Mallee industry needs a streamlined value chain with an intermediary party or organisation facilitating harvesting, transport and supply arrangements. This will limit capital requirements, multiple combinations of ownership, potential conflicts and costs.

This will be particularly important for the Mallee industry since the interdependence of the grower and the processor is less entrenched than in the sugar industry. Supply arrangements for mallee biomass are more likely to be driven by commercial opportunity than by necessity as is the case for sugar. Alternatively the cooperative harvesting groups / partnerships, found in the NSW Sugar Industry, provide a good example of how the growing sector, consisting of relatively small scale operators can maintain ownership of the supply chain while operating a highly efficient harvest and transport system.

A key requirement will be establishing confidence through long term contracts and supply agreements. This has to be informed by the availability of material and the feasibility of supply in the production or supply area which represents the profit centre.

Whilst the business and industry structures described provide the mechanism for things to occur, there remains an underlying requirement for a critical mass of supply within an economic radius. This is certainly the experience within the sugar industry where various ownership models and structures are in place and yet a number of mills have closed in recent years.

Supply chain management, planning and modelling

Many years of supply chain research in the sugar industry have highlighted the unique characteristics and requirements of different processing or supply areas where local situations will have an overriding effect. Research has also emphasised that the focus of supply chain planning and management should be broadened from the narrow logistical and operational technical issues to include improving the transparency of information, integration of the various businesses within the supply chain, and awareness of new market opportunities.

Relationships between sectors and participants in the supply chain are important and where there has been a tradition of cooperative relationships between participants, or a major effort has been placed to develop these relationships, there has been greater progress in improving the supply chain.

Sugar experience has shown the importance of promoting both tangible and intangible benefits of value chain improvement to stakeholders. While sometimes difficult to quantify they provide a key incentive for adopting system improvements.

Flexibility is essential in biomass supply chains to cope with and adapt to unforeseen events such as weather impacts, equipment failure, changes to industry participants and cross-sector relationships.

Appropriate standard contracts and protocols for services will support best management practice and equitable distribution of proceeds.

While diversification can add value to the industry, the impact on supply chain constraints needs consideration. The benefits and practicalities, capital requirements, and cost of production of each product as well as the sustainability of those markets over time need assessment.

While improved technology, such as the prototype harvester, will give a step change in cost efficiency, equal consideration must be given to integration with other elements of the supply chain and accumulated incremental improvements.

Account should be given to the social and human aspects of the supply chain. Trust will be a key ingredient and commitment should be sought to share information, improve the understanding by all participants of the drivers and operations of all sectors and increasing the size of cake as well as equitable apportionment of risks and rewards across the value chain.

A range of supply chain models and tools have been developed and applied in the sugar sector. These systems can be readily customised for mallee biomass supply and could include:

- Spatial mapping of mallee feedstock including age and planting arrangement to improve harvest management, reporting, mapping and data exchange.
- Monitoring of harvest progress using GPS tracking on harvesters and transport units to record area and volume of biomass removal, consignment delivery and, based on weighbridge data at the processor, paddock yield.
- Tracking of road haulage equipment based on GPS tracking to inform scheduling of deliveries and asset management.
- Harvest haul modeling of specific supply areas to optimise placement of loading zones and layout of mallee plantings.
- Refinement of mallee biomass production models to optimise farm layout and row spacing, given information on soil type, drainage and adjacent crop requirements to understand and account for both the farming and harvesting sectors.

Ideally application of these tools should encompass the entire value chain from biomass production, to harvesting and transport, processing and product diversification options.

Supply chain modelling and economic considerations

A desktop assessment of mallee harvest haul logistics was completed for Western Australian alley plantings based on the model widely used in the sugar industry.

The analysis showed that harvester pour rate has the largest impact on the cost of harvest and transport. Annual tonnage harvested also has a large effect on the cost of harvest since increased throughput provides better capital utilisation. Road haul distance has the next largest effect on cost on harvest-transport costs. With haul distances of 100km haulage costs are likely to be around \$15/t. Capital cost of equipment and belt spacing was shown to have a small impact on the cost of harvest.

For a small scale emerging industry (14,400 tonnes biomass harvested per year) and current prototype harvester performance (30green tonnes/hr pour rate) harvesting and infield transport costs are likely to be around \$30/green tonne. Combined with road haulage costs of \$15/tonne this would equate to a delivered cost to a processor of \$45/green tonne. The mallee grower and harvest/haul contractor would expect a profit and delivered cost is likely to exceed what a processor is prepared to pay.

For large scale industry development (144,400 tonnes biomass harvested per year) and future harvester performance (50green tonnes/hr pour rate) harvesting and infield transport costs would be around \$13/green tonne. Combined with road haulage costs of \$15/green tonne this would equate to a delivered cost to a processor of \$28/green tonne. This would provide a more appropriate cost of supply when compared with what the market would be prepared to pay. This area could theoretically be served by a single harvester working 11 hours per day.

Sugarcane harvesting and infield transport systems have a much lower cost of around \$6.50/tonne. This is based on the large scale of the industry (good capital utilisation), high crop yields (170tonnes/ha) and high delivery rates.

A key requirement for the mallee supply chain will be developing appropriate scale of supply, improved field layout to maximise harvest efficiency and larger harvester capacity to achieve pour rates in excess of 50 green tonnes/hr.

Appendix 1: Comparative Assessment with Sugarcane Supply Chain

Key components of and differences between the sugar and mallee supply chain as well as key issues and recommendations are outlined below based on review of each industry and workshop discussions including industry discussions at Perth (8 September 2011) and at Ballina (5 October 2011).

Sugar Industry	Mallee Woody Crop	Differences/Contrasts	Key Issues and Recommendations
Crop Production and Field Layout			
<ol style="list-style-type: none"> 1. Strong commercial focus on profitable sugarcane production. 2. Field and farm layouts and crop production practices are planned to maximise sugarcane production (quantity and quality). This applies to variety selection, row spacing, harvest cycle, ratoon management, field size and shape. 3. Sugarcane production land is typically prime agricultural production land producing high biomass yields based on good soils, high rainfall or supplementary irrigation. 4. Sugarcane supply areas are generally concentrated within 50-100km of the mill with intense production and cane covering >80% of the landscape. 5. Typically yields are 80-200tc/ha and cane will cover between 60-80% of the land area. 	<ol style="list-style-type: none"> 1. The focus is on profitable wheat production with Mallee initially seen as environmental service that had to pay its way. More recently it has become seen an alternative land use to diversify agriculture. Social-economic benefits are difficult to quantify economically. More recently recognition of economic opportunities for bioenergy and other products. 2. Field and farm layout focussed on wheat production. Typically 2 rows 2-3m apart separated by 70m of wheat with long alley row lengths. Increasing the number of Mallee rows reduces yield per row (moisture competition), reducing spacing between alleys compromises wheat production. 3. Mallee production is sparse and supply distance will be much higher for the same volume of material supplied to processor. 4. There has been a recent decline in mallee planting and there is a limited resource base to meet requirements of full scale industrial market or 100,000 to 200,000 green tonnes per year within 100km of a central factory. 5. Typically mallee production in alleys will be between 2-6gt/ha and will cover 5-10% of the land. 6. Full occupation of a paddock by mallee 	<ol style="list-style-type: none"> 1. The sugar industry has evolved to maximise profitability and sustainability from sugarcane production. Mallee plantings were initiated in WA to control salinity while generating some profit. More recently the emphasis upon mallees as an alternative enterprise on a small proportion of the farm has become the equal or predominant driver, while environmental drivers remain a significant factor in some regions.. 2. The sugar growing system is structured around maximum sugarcane production and reduced harvesting and infield transport costs. The Mallee system is structured around wheat production and layouts are not efficient from a harvest and transport perspective. 3. Biomass production potential of mallee (2-6t/ha) is very low when compared with sugar (80-200t/ha). This has an impact on vehicle utilisation and efficiencies. 4. Sugarcane has to be harvested at optimum age and quality whereas the value of mallee product does not change significantly. Mallee has less risk attached to harvest date. 5. Long alley length could result in high harvester field efficiencies when compared with sugar however distance to haul to loading pad will be greater than in sugar 	<ol style="list-style-type: none"> 1. Greater incentive in sugar to integrate supply chain with key driver being enterprise profitability. Returns from Mallee production seen as secondary to core business of wheat production and marginal so less incentive to optimise. 2. Changing Mallee farming systems is unlikely while wheat production remains the main economic driver. The only changes are likely to be in frequency of harvesting. 3. Consideration has been given to alternative mallee field layouts. Economic modelling has been undertaken to evaluate the most effective cropping of mallee and wheat (yield vs moisture competition) and changes to recommended configuration are unlikely in integrated plantings. 4. Consideration could be given to alternative denser mallee plantings in closer alleys (10-30m) on marginal land (ie without annual crops in the alleys) close to the processor to supplement existing and future mallee plantings that are wide-spaced belts integrated with annual cropping 5. Block plantings close to a processor will be important for large scale industry development. Planting would need to be in row configuration to improve harvesting efficiency. Row spacing would need to minimise suppressed growth due to competition.

	<p>might be represented by 200-300 mallee/ha, either on a uniform spacing of approximately 7x7m, or closely spaced belts to facilitate harvesting efficiency. Competition between mallees for soil moisture precludes higher density planting if long-term biomass production from many cycles of harvesting is a principal objective. These higher density block plantings would virtually exclude annual cropping from the paddock but would allow some grazing and stock shelter. This strategy may be suitable for soils not suited to annual cereal cropping (e.g. deep yellow acid sands).</p>		<ol style="list-style-type: none"> 6. Harvest efficiency is maximised when the concentration of biomass per metre of row is maximised and distance between belts is minimised. 7. Expansion in the sugar industry has generally been driven at a local mill area scale in response to market forces. Future expansion in mallee production will be driven by the market for biomass and farming systems and layouts will need to adapt to the economics of this supply arrangement. 8. Sophisticated information and data collection systems have developed in the sugar industry to manage supply areas and volumes. These systems are could be readily customised for biomass industries. 9. Where mallee planting is not intended for biomass removal, consideration will need to be given to protocols for carbon credits under the carbon farming initiative. 10. Mallee planting provides vegetative biodiversity in a wheat monoculture and the collateral benefits of this biodiversity and associated environmental dividend needs to be quantified. 11. A resource inventory of the existing mallee in WA is essential for development of commercial operations.
Sugar Industry	Mallee Woody Crop	Differences/Contrasts	Key Issues and Recommendations
Harvesting Transport and Storage Systems			
<ol style="list-style-type: none"> 1. Sugar plantations typically cover large continuous blocks of typically greater than 20ha allowing high harvester utilisation and efficiencies 2. Sugar industry has collected a lot of information related to harvesting best practice and machine performance. 3. Sugarcane presents a fairly uniform crop to be managed by a harvester. 4. Material handling characteristics of sugarcane has been well researched and documented and machinery designed to provide optimum pouring and transport conditions. Billet length and extraneous matter can be well controlled in current 	<ol style="list-style-type: none"> 1. Mallee typically planted in double rows separated by 50m-150m of wheat and other crops. 2. There is very little published data available relevant to the mallee harvesting systems 3. Mallee biomass has a variable characteristic and does not flow very well. Tipping and bridging can be a problem and bulk density can be low. Control of chip quality, leaf and twig material is difficult in the harvester, all of which affect material flow, angle of repose, tipping etc. 4. Bulk density is not well understood and may range from <300kg/m³ after tipping 	<ol style="list-style-type: none"> 1. High shift-average sugarcane harvester throughput of typically 60 to 90 tonne/hr are achievable versus likely 20-40 tonne/hr for mallee. Low pour rates result in high costs of harvesting. 2. Sugarcane harvester field efficiencies are typically 50% which would be expected to be lower than for mallee 70-80% given the long row lengths, low harvesting speeds, and reduced number of times the harvester needs to turn per hour. 3. Good quality data on mallee harvester performance is being collected which will inform decisions on improved harvester management 	<ol style="list-style-type: none"> 1. Mallee harvesting costs are expected to be 3 times that for sugarcane. With increased production volumes and higher delivery rates this could drop to twice current sugarcane harvesting costs. New field layouts and increased harvester performance need to be considered to reduce these costs. 2. Current trials provide opportunities to optimise harvest performance and collect appropriate information on fuel consumption, vehicle utilisation, harvester location, power and pressure and material flow, bulk density etc. This should include matching the power in different parts of the harvester. 3. Bulk density changes with tipping and

<p>harvesters.</p> <ol style="list-style-type: none"> 5. Current research is focussing on improved transport efficiencies for whole crop cane through vibration and compaction. 6. Harvester pour rates in sugar are typically 80-200t/hr. The harvester efficiency in cane harvesting is typically around 50% based on lost time waiting for bins or turning at headlands. 7. In sugar cane harvesting product separation (trash and cane) takes place on the harvester. This is not the most efficient place for product separation and losses are typically 7-26%. 8. A reliable and balanced cane supply is critical to the sugar industry both within the day and across the harvesting season. The industry has moved to harvest monitoring (GPS) and mapping to allow better scheduling and planning. Satellite mapping is also used to monitor harvesting and cane supply. 9. Harvesting costs have generally been on a flat rate of \$5-\$7/tc. There has been a move to differentiate payment for burnt vs green cane and as a base rate plus fuel costs (Typically <\$7/tc). 10. There has been consolidation of harvester groups to achieve better scales of efficiency with annual output rates between 13,000 and 150,000tons per harvester with most contractors targeting around 100,000 tc with minimal moving around. 11. Harvesters operate as independent to the miller, grower structure. Mills generally operate narrow guage railway links. Costs are covered by the mill. There is little incentive for growers to optimise sidings. 12. Harvest to crush delays are critical and are generally targeted at <24hrs. Billet length, burnt vs green can and weather all affect deterioration. 	<p>(to be confirmed by trials) to 400kg/m³ after consolidation.</p> <ol style="list-style-type: none"> 5. Harvester pour rates are still being assessed. At speeds of 3 km/h pour rates of up to 35 gt/h have been achieved with the current prototype (2011) and this is primarily limited by installed power. It is anticipated that rates in excess of 50 gt/h will be achieved in future prototypes. Harvester efficiency of up to 80% could be achieved due to long row length and relatively low speed while harvesting. 6. Harvest and haul to field edge costs likely to be high initially (\$25-35/gt) when production volumes are low (15,000t/yr) and pour rates are low (20-30t/hr). These would improve (\$12-\$20/gt) if production scaled up (140,000t/yr) and pour rates improved (30-50t/hr). 7. High pour rates and long haulout distances will require more than 2 haulout units with increased capital cost. Haul distances of up to 4km may occur given low biomass yields in narrow belts. Change from over to under capacity of the system is likely to occur owing to a big range in haul distance. The use of a two-stage haulout, using two haulouts within the paddock and a single high speed haulout transporting bins several kilometres to the roadside landing is being investigated. 8. Losses on mallee harvester are not expected to be as severe (given no product separation) however transporting all biomass to the factory may compromise bulk density and payload. 9. Haulout capacity will need to align with road haulage capacity. Half trailer (35m³, 14 green tonne) or full trailer (70m³, 28 green tonne) is likely with trailer tip or exchange at the landing. 10. Owing to long road transport distances (100km one way) multiple road trailers are required and side loading and side tipping appear essential. 11. Appropriate stockpiles will be required to balance supply with processor demand. This is linked to in field operation timing 	<ol style="list-style-type: none"> 4. Mallee biomass will be more difficult to move, tip and transport. 5. Separation on the harvester will result in product losses in field but may result in better transport efficiencies. This is also impacted by the product required to be delivered to the processor (ie is there a market for all products, especially the leaf). 6. Greater reliability of biomass supply results in lower balancing storage. In the sugar industry there are multiple suppliers which help balance supply. For mallee with a single harvester and limited number of transport unit's reliability will be low so relatively large storage in stockpiles will be important. 7. Sugar industry relies largely on rail transport. Given long road transport distances likely and low value of delivered mallee biomass, savings through full utilisation, maximum payload and quick turn-around time will be a pre-requisite. 	<p>transport and associated impact on product handling is not known.</p> <ol style="list-style-type: none"> 4. Consideration will need to be given to appropriate tipping and pouring options. Harvester and chipper design could be impacted in terms of chip size and the tradeoff between chipping costs (chip size) and transport costs (packing and bulk density). 5. Consideration will need to be given to ways to improve pour rates and efficiencies. This could inform changes to the mallee row arrangement to better suit commercial harvester and transport constraints. Harvester operation and production appears optimised if mallees are close together (<2m intrarow spacing) in +3m spaced rows. 6. Haulout efficiency will be maximised if production per paddock hectare is maximised and haul distances to the road landing are reduced. Increasing the number of landings needs to be balanced with the cost of landing establishment, retrieving empty bins and coordinating with road haulage vehicles. The use of two stage hauling out using two paddock haulouts and a high speed "shunt" needs to be investigated. 7. Harvest and transport systems will be impacted by the nature of the material to be delivered (eg chips vs leaf material) which is impacted by the product stream (eg bioenergy vs mallee oil). 8. Consideration could be given to pre-processing at local nodes eg pelleting, leaf separation. However costs and efficiencies would need to be assessed. 9. Stockpiles are likely to be essential between the harvester and road transport. This is likely to be in the form of trailers stored at the road landing or bins that can be self loaded onto the trailer. Infield loading of road transport will be limited by field access and year round soil/field conditions. 10. Stockpiles at the processor will be required to balance supply with processor demand. 11. The nature of the biomass material will impact deterioration and the product to be produced will dictate allowable delivery delays. 12. The current harvester is limited by available
---	--	---	--

	<p>(eg 8hr/day), processor demand (eg 365/24/7), mechanical failures, the available spare capacity in the supply chain, fire risk conditions in summer, wet weather and ground conditions, and availability of alternative biomass material for the processor.</p> <p>12. Biomass spoilage will be influenced by the biomass material itself (eg moisture, leaf content) and product required (eg eucalyptus oil vs bioenergy). This will be seasonally dependent. Product separation on delivery (eg chip vs leaves) would improve stockpile management and product differentiation.</p> <p>13. Limited information is available on the spatial distribution of mallee plantings. Some information has been captured in an access database and basic mapping, however this does not provide accurate information on harvestable mallee.</p> <p>14. An efficient supply chain will not be a response to increasing deregulation or terms of trade but a prerequisite for a new industry.</p>		<p>power which impacts pour rate a critical factor in the delivered biomass cost and future prototypes will need to address this.</p> <p>13. Maneuverability, mobility and associated soil compaction issues will need to be considered in the selection of the tracked or wheeled configuration harvester and in-field transporters.</p> <p>14. Transport efficiencies may be improved by leaving residue materials such as bark and twigs behind in the paddock, however separation on the harvester has a low chance of success and will result in a more complex machine design and product losses in field.</p> <p>15. Harvester pour rate has the largest impact on the cost of harvest and transport. Annual tonnage harvested also has a large effect on the cost of harvest</p>
Sugar Industry	Mallee Woody Crop	Differences/Contrasts	Key Issues and Recommendations
Industry and Business Structures			
<p>1. Sugar industry growers, millers and hauliers are co-dependent and well integrated along supply chain.</p> <p>2. Profit Centre of sugar industry is the mill supply area. Miller and Grower are jointly dependent on each other. Sugar content deteriorates quickly after harvest. Both miller and grower need to be profitable for economic sustainability. Miller seeks to ensure that cane production is the most profitable crop to maximise supply.</p> <p>3. Millers generally have "ownership" of cane transport via rail supply networks or contracted road transport.</p> <p>4. Cane transport generally consists of single or limited number of operators ie one transport contract</p>	<p>1. Mallee industry supply chain is fragmented with growers who see Mallee as non-core business, harvesting contractor (market opportunity still to be justified), and Processor (Energy Company) who may not value Mallee as an important component of energy supply.</p> <p>2. New commercial opportunities through Mallee production. No history or established relationships or rules of engagement</p> <p>3. There is an expectation that harvesting and transport will be driven by third parties i.e. broker Mallee supply</p> <p>4. Power generation companies do not have agricultural context. They do not want to have to deal with multiple farmer suppliers.</p>	<p>1. Difficult to get integration along a fragmented supply chain with different "owners" for whom Mallee supply or processing may not be viewed as "core business". Sugar industry developed around regulation. Rules to manage risk and manage industry participants. Recent deregulation for independent decision on supply contracts but based on a mature viable business structure.</p> <p>2. Harvesting / Transport responsibilities need to be clarified in mallee.</p> <p>3. Potentially multiple transport players depending on who takes responsibility ie grower vs energy company</p> <p>4. Opportunity to implement optimised supply chain arrangements as opposed to optimising existing structures</p>	<p>1. Important to get organisations involved in Mallee supply chain to discuss and outline their vision and requirements.</p> <p>2. The industry has the opportunity of a relatively clean slate to develop appropriate supply arrangements. The imbalance between the processor (established and powerful with alternative supply options) and the grower (for whom Mallee is a secondary income compared with wheat) is an issue.</p> <p>3. There is a catch 22 with farmers unlikely to plant mallee without a commercial incentive and processors unlikely to invest without a secure supply.</p> <p>4. Need for an intermediate entity to occupy space between grower and processor and make a business of a profitable supply chain. Neither the grower nor the processor has a real interest</p>

<p>5. Growers have ownership of harvesting operations via owner operator or contractor. Across industry this is over capitalised</p> <p>6. Harvesting operations are controlled by the miller to maintain adequate supply ie limited storage potential</p> <p>7. Harvesting and transport is dictated by cut to crush delay.</p> <p>8. Costs for harvesting and transport are generally socialised i.e. no difference between farmers. The miller covers the cost of rail transport. A flat rate is charged per tonne.</p> <p>9. Milling is highly sensitive to local cane supply.</p> <p>10. The sugar industry developed from a very regulated industry.</p> <p>11. Sugar industry is largely based around raw sugar production with recent efforts into whole cane harvesting for co-generation being unsuccessful.</p>	<p>5. Industry based on large number of small resource owners will be complex to manage.</p> <p>6. Mallee industry transport will be most likely road based. Possibly an existing prime mover contractor with specialised trailers, or transport and harvesting could be jointly owned, as is common in forestry systems.</p> <p>7. Harvesting operations unlikely to be individual grower owned. If owned by processor or independent contractor best interests of farm production systems are not always met unless payment and penalty systems apply. Grower cooperative systems may provide better model.</p> <p>8. Harvested Mallee may have greater storage periods and harvesting and processing may not be as sensitive as sugar to cut to process delays.</p> <p>9. Traditional grain based and wood chip transport systems are costed on haulage distance and it is likely that mallee will be the same.</p> <p>10. Limited understanding of seasonal production and source of supply.</p> <p>11. Mallee is more likely to have multiple product streams.</p>	<p>5. Harvest scheduling may not be as critical for mallee since harvest to process delays will not compromise quality as much as in sugar and short term stockpiling is possible.</p> <p>6. May be able to store the material longer before processing. Can't store the whole-tree biomass for more than 4-5 days due to risk of spontaneous combustion.</p> <p>7. Harvesting and transport costs will be at growers expense, either directly (contractor is engaged by the farmers), or indirectly (the biomass value is determined primarily by the biomass processor, who engages the harvest and transport contractor, and farmers are paid the remainder as stumpage for the standing mallee).</p> <p>8. Energy companies don't appear to be as engaged with crop production in mallee as sugar millers are in cane.</p> <p>9. Potentially multiple product streams from Mallee, leading to conflicting handling requirements.</p>	<p>in the supply chain.</p> <p>5. Processor is unlikely to purchase mallee production land or lease mallee strips due to focused business interests and complicated business arrangements.</p> <p>6. Consideration needs to be given to the need for a growers' commercial representative, similar to the role of the former Oil Mallee Company.</p> <p>7. Streamlining harvest and transport costs will require coordination at processing end.</p> <p>8. Single operator for harvesting and transport most likely.</p> <p>9. The scale of the operation would initially be very small, a couple of harvesters. This increases the risk of supply breaks.</p> <p>10. Seasonal Mallee supply will need to be accurately determined to manage harvesting and processing although daily scheduling may not be as sensitive as sugar.</p> <p>11. Clarity of likely product streams and implications for cut to processing delay.</p> <p>12. Industry development will be driven by who values the product most.</p> <p>13. Energy companies will need to take an interest in farm based production issues, even though they are unlikely to be interested in trading in biomass.</p> <p>14. Needs to be a large scale resource to build the business around into which small scale mallee producers can feed material.</p> <p>15. Long term contracts may be required to guarantee supply and attract farmers to grow the biomass.</p> <p>16. Need to understand different criteria for raw material handling depending on use.</p> <p>17. Payment systems and business structures vary in sugar cane and provide a range of models from which a new mallee industry will be able to choose.</p>
Sugar Industry	Mallee Woody Crop	Differences/Contrasts	Key Issues and Recommendations
Processing, Planning, Economic and Market Considerations			
1. Strong commercial focus on profitable	1. Focus on profitable wheat production.	1. The sugar industry has evolved to maximise	1. Greater incentive in sugar to integrate supply

<p>sugarcane production and sugar extraction.</p> <ol style="list-style-type: none"> 2. Profitability through sugar production is the key driver for all stakeholders 3. Primary market is sugar production. More recent focus on alternative products and by-products has been on the back of an already viable sugar product base. 4. Sugar price is determined by processor (miller and refiner) and apportioned to producer after transport costs paid. Price affected by domestic and international price (80% export) and exchange rate. 5. Sugarcane is the only feedstock for sugar production in Australia. 6. Sugar industry and company profits are directly linked to an assured cane supply of suitable quality and quantity. 7. Fundamental research into sugarcane harvesting and transport systems has dwindled in recent years. Much innovation occurs within the mill area and producers/contractors. Formal research is increasingly focused on systems approach 8. Cane payment is based on sugar price and recoverable sugar content. Based on aggregate production for mill area. Traditionally there has been a split between miller 1/3 and grower 2/3 - a relative payment system is in place to account for quality changes through season. Payment to the grower is based on sugar only, other proceeds (molasses etc) belongs to miller. The Sugar Act sets a framework for negotiations. 9. Increased economies of scale are improving viability (growth or acquisition). 	<p>Mallee has generally been seen as an environmental service that must pay its way. More recently there has been increased emphasis upon the commercial value of biomass.</p> <ol style="list-style-type: none"> 2. Primary market is biomass for energy markets including pyrolysis bio-oil (precursor to transport fuel), fuel pellets, co-firing with coal, thermal energy (boiler fuel) and other products such as charcoal and eucalyptus oil. 3. Biomass prices for electricity generation driven by renewable energy targets (20% by 2020), network power charges, competing technologies and renewable energy certificate rates. Uncertainty in future policy and pricing of REC's is a key issue. 4. Energy Producers such as Verve Energy are actively developing renewable energy opportunities, especially wind and solar. 5. Coal is the primary feedstock for electricity generation in Australia. The established infrastructure of coal-fired power stations and the economies of a large scale concentrated fuel resource gives coal a significant economic advantage over biomass. Demand for biomass for electricity generation is driven more by regulatory mechanisms and policies (REC's) which are immature and subject to policy change. Biomass complements the energy company's portfolio of renewable energy sources (wind, solar, geothermal) given that it is a base load generation system. 6. Typically mallee will have the following pricing structure (Farmer stumpage \$15-\$30/gt; Energy market \$50-70/gt. Thus harvest and transport needs to be \$30-\$35/gt). 7. In Mallee bioenergy production there will be a fixed price determined by other established sources of energy, so farmers will be price takers. 8. Research into biomass harvesting is relatively limited and has focused on the harvester development currently 	<p>profitability and sustainability from sugarcane production. Mallee plantings were initiated to control salinity.</p> <ol style="list-style-type: none"> 2. Sugar mills have developed sophisticated sugar extraction processing capability over many years. New by-products processing requirements are in many cases complementary to sugar extraction technologies. Sugar refineries focus on adding value to the product by preparing and packaging sugar for different market sectors. Electricity generators are not well suited to developing new market opportunities for Mallee. They are more akin to a sugar refinery that is single product (ie sugar) focused. 3. The sugar value chain is well developed and has committed stakeholders who are fully dependent on one another. 4. The bioenergy value chain is less developed and has competing supply products. 5. The sugar industry processor (miller) and the bioenergy producer have power over the supply chain. The sugar miller has arguably a better understanding of the producer's needs. Many sugar millers also have sugarcane growing operations which are used to manage supply risk. 6. Energy markets will generally see the biomass supply as a commodity and have no interest in becoming involved in supply chain planning and management. 7. In sugar industry the growing sector has some influence on price paid for cane (through their representing bodies (Canegrowers)) and in some regions (eg Mackay) are rewarded through the pricing mechanism for good quality cane. In the mallee industry producers will be price takers and there is no trading commercial representation of mallee producer interests. 8. 	<p>chain with key driver being enterprise profitability. Returns from Mallee production seen as secondary to core business of wheat production and marginal so less incentive to optimise.</p> <ol style="list-style-type: none"> 2. Energy markets are less likely to be proactive in developing alternative resource streams to their existing sources. New businesses will need to develop to take up these other energy market opportunities. There are no other players in this space which are analogous to the sugar miller, with the possible exception of Delta Energy. 3. Key barriers to biomass markets likely to include marginal economics under current policy settings; inadequate volumes in biomass production; lack of integrated supply chain; uncertainty in volume of resource available; lack of established market for mallee biomass; limited interest in biomass supply within agricultural sector and electricity generating sector. 4. The economic viability of Mallee for bioenergy production better suited to thermal energy production and less to electricity generation given processing efficiencies. Consideration to be given to local markets at a local level, for example thermal energy for heating at abattoirs, hospitals and other demand points (replacement of LPG). 5. New markets will be required for Mallee biomass. This could involve a business who pre-processes the biomass (analogous to a sugar mill) separating the various components (eg trash, leaves, chips) for separate processing (eg oil, charcoal, bio-oil, electricity generation (analogous to the sugar refinery). 6. Integration of energy companies up the supply chain to own production areas or control management of supply is unlikely. 7. Energy market or regulatory mechanism to increase the mallee biomass price may be required. 8. In the Mallee industry the raw material supply is in place, however the market needs to be developed. Technologies are in place to process the crop however the economics are questionable. New markets may need to be
--	---	---	---

	<p>underway. There is not a strong producer/contractor element to provide innovation.</p> <ol style="list-style-type: none"> 9. Electricity and biofuel markets likely to be based on large scale industrial processing which raises the supply chain issues referred to elsewhere. Currently there is insufficient reliable local feedstock for such a large scale operation. 10. Alternative markets of thermal energy, fuel pellets, co-firing and co-generation, oil extraction and charcoal production are under various scales of development using other biomass materials and provide opportunity for mallee. 11. Conversion to fuel pellets would reduce cost of transport through higher bulk density, consistent properties, ease of handling and long term storage. Aim would be to limit transport of chips (400kg/m³ at 40% moisture content) over a short distance to the pellet facilities with further long haul distribution of higher value pellets (680kg/m³ at 10% moisture). 12. Post processing of material from the harvester (screening, re-chipping, drying) could improve the wood chip product. Tradeoff between the pellets and improved wood chip material (ie costs per GJ of delivered fuel) would need to be assessed. 13. Market for eucalyptus oil is small and high value (about \$10 per kg); however at extraction of 1% by mass of biomass could return \$10/gt delivered biomass (based on only \$1/kg oil ex distillery net of extraction cost). 		<p>developed which could include small local usage (eg mulch, thermal energy).</p> <ol style="list-style-type: none"> 9. Alternative markets for different parts of the biomass (e.g. woodchips, leaf, twigs) will require further processing (eg separation, pelleting) with associated costs. Beneficial income would need to exceed incremental processing costs. 10. Multiple markets will increase focus on quality of material supplied and will impact criteria for good quality 11. A mallee industry based on a single market operator who controls the supply chain will reduce the power of the biomass supplier. 12. Uncertainty in the market and future pricing would negate a processor negotiating long term supply contracts. 13. Unlikely for a processor to invest in biomass supply unless there was an established market that could be made more secure by investment in the supply chain. 14. Small scale markets close to the source could be the basis of early supply chain operations. These niche markets may offer relatively high value for the biomass even if they are limited in scale. 15. As the Industry expands, most significant potential market will probably involve emerging technologies such as liquid fuels via pyrolysis. 16. The focus of supply chain planning and management should be broadened from the narrow logistical and operational technical issues to include improving the transparency of information, integration of the various businesses within the supply chain. 17. There are both tangible and intangible benefits of value chain improvement that need to be communicated. 18. Flexibility is essential in biomass supply chains to cope with and adapt to unforeseen events. 19. While diversification can add value to the industry, the impact on supply chain constraints needs consideration.
--	--	--	--

References

- Agnew, J 2002. A Participatory Approach Towards Improving Industry Sector Profits Through Improved Harvesting Efficiency. Bureau of Sugar Experiment Stations Publication SD02023, Brisbane, Australia.
- Abadi A, Bartle J and Giles R 2008. Commercial Feasibility of Woody Biomass Production in Wheatbelt Agriculture. Bio-energy Australia 2008 Conference, 8 December 2008, Melbourne
- Antony G, Prestwidge DB, Sandell GR and Higgins A 2003. Scope for Cost Savings from Harvesting Rationalisation in the Australian Sugar Industry. Proc. Aust. Soc. Sugar Cane Technol., Vol. 25, (CDROM, 8 pp).
- Bartle, J, Huxtable, D and Peck, A 2011. Productivity Interactions of Integrated Oil Mallee Farming Systems. Chapter 2 in RIRDC Project No PRJ000477: Hydrological impacts and productivity interactions of integrated oil mallee farming systems: Landscape scale effects of dispersed mallee plantings. Edited by Kim Brooksbank. RIRDC project PRJ000477 (in press).
- Bartle, J, Olsen, G, Cooper, D and Hobbs, T 2007. Scale of Biomass Production From New Woody Crops for Salinity Control in Dryland Agriculture in Australia. Int. J. of Global Energy Issues, 2007, 27, 115.
- Bartle, J and Abadi, A 2010. Towards Sustainable Production of Second Generation Bioenergy Feedstocks, Energy Fuels, 24, 2–9.
- Beattie, R and Crossley, R 2006. Achieving World's Best Practice Harvesting and Transport Costs for the NSW Sugar Industry, Sugar Research and Development Corporation NSC006 Final Report, Brisbane, Australia.
- Bezuidenhout, C and Bodhanya, S 2010. Identifying Opportunities in South African Sugarcane Supply Chain Systems. School of Bioresources Engineering and Environmental Hydrology. University of KwaZulu-Natal. Pietermaritzburg. South Africa.
- Boston Consulting Group. 2004. Boston Consulting Group Report to Canegrowers, Review of Constraints on Industry Competitiveness and Innovation, Brisbane.
- Brotherton, G 2002. Harvester Performance Testing - Literature Review: Loss Measurement in Sugarcane Harvesting. Bureau of Sugar Experiment Stations Publication CD02008, Brisbane, Australia.
- Canegrowers 2002. Submission to the Independent Assessment of the Sugar Industry. Canegrowers, Brisbane.
- Canegrowers 2010. "Australian Sugarcane - Cane Payment Information." Retrieved 23 August, 2010.
- Chapman, FL and Grevis-James, I 1998. Investigations into a Differential Charging System for Harvesting. Proc. Aust. Soc. Sugar Cane Technol., 20: 43-46.
- Cooper D, Bartle J, Schilizzi S and Pannell D 2001. Oil Mallee Must Look to Multi-Product Industries, In Proceedings 45th Annual Conference of Australian Agricultural and Resource Economics Society Inc, 23-25 January 2001, Adelaide.

- Cooper, D, Olsen, G and Bartle, J 2005. Capture of Agricultural Surplus Water Determines the Productivity and Scale of New Low-Rainfall Woody Crop Industries. *Australian Journal of Experimental Agriculture*, 45:1369-1388.
- Crook, TD, Pope, GM, Staunton, SP and Norris, CP 1999. A Survey of Field CCS versus Mill CCS. *Proc. Aust. Soc. Sugar Cane Technol.*, 21: 33–37.
- Crossley, R and Dines, G 2004. Integrating Harvester GPS Tracking Data with a Spatial Harvest Recording System, *Proc. Aust. Soc. Sugar Cane Technol.*, 26, (CDROM, 11 pp).
- Crossley, R and Markley, J 2011. AGDAT: Spatial Applications to Improve Harvest Management, Data Recording, and Reporting and Data Exchange Between Organisations. *International Sugar Journal* 2011, Vol 113, No. 1354
- DaCunha Mello, R and Harris, HD 2000. Cane Damage and Mass Losses for Conventional and Serrated Basecutter Blades. *Proc. Aust. Soc. Sugar Cane Technol.*, 22, 84-91.
- Davis, RJ and Norris, CP 2000. Improved Feeding of Green Cane by Harvesters. Bureau of Sugar Experiment Stations Publication SD00009, Brisbane, Australia.
- Davis, RJ and Norris, CP 2001. Impact of Chopper Harvesting on the Translation of Field CCS to Factory Realised CCS. Bureau of Sugar Experiment Stations Publication SD01007, Brisbane, Australia.
- Davis, RJ and Norris, CP 2002a. Optimising the Forward Feeding Zone of Chopper Harvesters: Development of a Research Platform, *Proc. Aust. Soc. Sugar Cane Technol.*, 24, (CDROM, 1 p).
- Davis, RJ and Norris, CP 2002b. Improving the Feeding Ability of Sugarcane Harvesters, *Proc. Aust. Soc. Sugar Cane Technol.*, 24, (CDROM, 12 pp).
- Davis, RJ and Norris, CP 2003. Optimising the Forward Feeding Zone of Harvesters: Development of a Research Platform, *Proc. Aust. Soc. Sugar Cane Technol.*, 25, (CDROM, 12 pp).
- Davis, RJ and Schembri, MG 2004. Enhancing Harvester Forward-Feeding Performance: An Exercise in Optimizing Machine-Crop Interactions, *Proc. Aust. Soc. Sugar Cane Technol.*, 26, (CDROM, 14 pp).
- Dawson, M 2004. Cane Deterioration – Literature Review, Dawson Biological Consulting Pty Ltd, Brisbane
- Dogramaci, S and Waterhouse, A 2004. 'Engineering Salinity Solutions', First National Salinity Engineering Conference, Perth, Western Australia, Institution of Engineers, Australian Capital Territory
- Dunlop, M, Turner, G and Howden, S 2004. Future Sustainability of the Australian Grains Industry: a Consultancy Report Prepared for the Grains Council of Australia and Grains Research and Development Corporation, CSIRO Sustainable Ecosystems, Canberra, Australian Capital Territory, p.147.
- El Bassam, N 2010. Handbook of Bioenergy Crops: A Complete Reference to Species, Development and Applications. Published by Earthscan Ltd Dunstan House, 14 St Cross St London. EC1N 8XA. ISBN: 978-84407-854-7.
- Enecon 2001. Integrated Tree Processing of Mallee Eucalyptus. A Report for RIRDC/Land & Water Australia/FWPRDC Joint Venture Agroforestry Project. *RIRDC Publication No 01/160*.

- Eriksson P 2000. Skogforsk Review of Systems for Logging Residues Handling in Sweden. *New Zealand Journal of Forestry Science* 30(1/2): 88-93.
- Esquivel, M, Cabezas, L, Hernandez, B, Marrero, S, Fernandez, F, Ponce, E, Quintana, L and Gonzalez, L 2007. Harvester Automation and Precision Agriculture Trials in Queensland 2006, *Proc. Aust. Soc. Sugar Cane Technol.*, 29, (CDROM, 9 pp).
- FFI CRC 2010. Energy Tree Crops: Renewable Energy from Biomass could be the Driver to Large Scale Adoption of Woody Crops and Structural Improvement to Dryland Agricultural Systems in Australia. Future Farm Industries Cooperative Research Centre, University of Western Australia, Crawley.
- Fuelling, TG and Wright, R 1997. GPS and GIS: Management Tools for Millers and Growers. *Proc. Aust. Soc. Sugar Cane Technol.*, 19:14-20.
- Fuelling, TG 1999. Harvesting Quality Sugar Cane, *Proc. Aust. Soc. Sugar Cane Technol.*, 21, 28-32.
- Garson, CA 1992. Control of Harvester Basecutter Height. *Proc Aust. Soc. Sugar Cane Technol.*, 14:156-162.
- Garside, AL, Smith, MA, Chapman, LS, Hurney, AP and Magarey, RC 1997a. The Yield Plateau in the Australian Sugar Industry: 1970-1990. *In: Keating, B.A., Wilson, J.R. (Eds.), Intensive Sugarcane production, Meeting the Challenges beyond 2000.* CAB International, Wallingford, UK. pp. 103-124.
- Gaucher, S, Le Gal, PY and Soler, G 2003. Modelling Supply Chain Management in the Sugar Industry. *Proceedings South African Sugar Technologists Association.* 2003.
- Giles, RC and Harris, HD 2003. Developing a Biomass Supply Chain for New Australian Crops. Paper presented at IEA Bioenergy Task 30 (Short Rotation Crops for Bioenergy) Conference, Tauranga, NZ, 1-5 December 2003.
- Gomez, J C, Chapple, D, and McDonald L 2006. Sugar Losses in Burnt and Green Cane Harvesting in Argentina. *Proc of Aust Soc Sugarcane Technol.*
- Grimley, SC and Horton, JF, 1997. Cost and Service Improvements in Harvest/Transport through Optimisation Modelling. *Proc. Aust. Soc. Sugar Cane Technol.*, 19: 6-13.
- Henkel, CR, Fuelling, TG and Ridge, DR 1979. The Effect of Harvester Basecutter Setting on Dirt in the Cane Supply and Cane left in the Field. *Proc. Aust. Soc. Sugar Cane Technol.*, 14:156-162.
- Higgins, A and Archer, A 2005. Increasing the Capacity to Identify and Action Value Chain Integration Opportunities. Final Report Project CSE013. Sugar Research and Development Corporation. 2005.
- Higgins, A and Kozan, E 1997. Modelling Train Delays in Urban Networks. *Transportation Science*, 32: 347-357.
- Higgins, AJ 2006. Scheduling of Road Vehicles in Sugarcane Transport: A case study at an Australian sugar mill. *Europ. J. Operat. Res.*, 170: 987-1000.
- Higgins, AJ and Davies, I 2004. Capacity Planning in a Sugarcane Harvesting and Transport System using Simulation Modelling, *Proc. Aust. Soc. Sugar Cane Technol.*, 26, (CDROM, 9 pp).

- Higgins, AJ and Langham, DA 2001. Harvester Roster Optimisation: Case Studies in the Mackay Region, *Proc. Aust. Soc. Sugar Cane Technol.*, 23: 37-43.
- Higgins, AJ and Laredo, L 2006. Improving Harvest and Transport Planning within a Sugar Mill Region. *Journal of the Operational Research Society*, 57, 367-376.
- Higgins, AJ, Antony, G, Sandell, G, Davies, I, Prestwidge, DB and Andrew, B 2004. A Framework for Integrating and Optimising a Complex Harvesting and Transport System for Sugar Production. *Agricultural Systems*, 82: 99-115.
- Higgins, AJ, Prestwidge, D, Sandell, GR, Antony, G, Laredo, L and Thorburn, PJ 2006. Integrating and Optimising Farm-to-Mill decisions to Maximise Industry Profitability. Sugar Research and Development Corporation project CSE005 Final Report, Brisbane, Australia.
- Higgins, AJ, Prestwidge, D, Sestak, F, Markley, J, Attard, S, Laredo, L, Jiao, J, Power, A and Ford, A, 2005. Adoption Pathways for Alternative Cane Supply Options Across the Sugar Industry. Project CSE003 Final Report. Sugar Research and Development Corporation, Brisbane.
- Hildebrand, C 2002. Independent Assessment of The Sugar Industry, Report to the Hon Warren Truss, Minister for Agriculture, Fisheries and Forestry, Australian Government Canberra.
- Hobson, PA and Wright, PG 2002. An Extended Model of The Economic Impact of Extraneous Matter Components on The Sugar Industry. Final Report, SRDC project SRI090, Sugar Research Institute Project Report Number 9/02.
- Hobson, P A 2003. Progress in the Development of Bagasse Gasification Technology for Increased Co-generation in the Australian Sugar Industry. *Proc of Aust. Society of Sugarcane Technol: Vol 25* .
- Hockings, PR, Norris, CP and Davis, RJ 2000. Chopper Systems in Cane Harvesters: B: Results of a Test Program, *Proc. Aust. Soc. Sugar Cane Technol.*, 22: 250-255. Holmgren, B. R. (n.d.). J Fast Pyrolysis and Bio-Oil Upgrading. . www.ascension-publishing.com/BIZ/HD50 .
- <http://asdi.curtin.edu.au/csrp/projects/4c2.html>. Biomass 1A: Mallee Leaf/Twig Charcoal as Metallurgical Reagents (4C2). (n.d.).
- Huxtable, D and Bartle, J 2007. Predicting Mallee Biomass Yield in The WA Wheatbelt. An interim report on investigations, Department of Environment and Conservation, February 2007
- Industry Commission 1992. The Australian sugar industry, Report no. 19, Commonwealth of Australia.
- Jensen, T, Baillie, C, Bramley, R, Di Bella, L, Whiteing, C and Davis, R 2010. Assessment of Sugarcane Yield Monitoring Technology for Precision Agriculture. *Proc. Aust. Soc. Sugar Cane Technol.*, 32.
- Jones, R 2004. Cane Harvesting to Improve Industry Performance. Sugar Research and Development Corporation, Brisbane, SRDC Technical Report 2 / 2004
- Keating, BA, Robertson, MJ, Muchow, RC and Huth, NI 1999. Modeling Sugarcane Production Systems 1. Development and Performance of The Sugarcane Module. *Field Crops Res.*, 61: 253-271.
- Keating, BA, Antony, G, Brennan, LE and Wegener, MK 2002. Can Renewable Energy Contribute to a Diversified Future for the Australian Sugar Industry? *Proc. Aust. Soc. Sugar Cane Technol.*, 24: 26-39.

- Kroes, S and Harris, HD 1994. Effects of Cane Harvester Basecutter Parameters on the Quality of Cut. Proc. Aust. Soc. Sugar Cane Technol., 16:169-177.
- Kroes, S and Harris, HD 1995. A Kinematic Model of the Dual Basecutter of a Sugarcane Harvester. Journal of Agricultural Engineering Research, 62:163-172.
- Kroes, S 1997. Cane Loss Due to Basecutter and Knockdown Damage. Proc. Aust. Soc. Sugar Cane Technol., 19:155-161.
- Lavarack, BP, Hodgson, JJ, Broadfoot, R, Vigh, S and Venning, J 2004. Improving the Energy Efficiency of Sugar Factories: Case Study For Pioneer Mill. Proc. Aust. Soc. Sugar Cane Technol., Vol. 26.
- Lawes, RA, McDonald, LM, Wegener, MK, Basford, KE and Lawn, RJ 2004. Factors Affecting Cane Yield and Commercial Cane Sugar in The Tully District. Australian Journal of Experimental Agriculture, 42, 473-480.
- Lefroy, E, Hobbs, R J, O'Connor, M and Pate, JS 1999. 'Special issues: agriculture as a mimic of natural systems', Agroforestry Systems, Vol. 45, pp.1-436.
- Linedale, AI and Ridge, DR 1996. A Successful Campaign to Minimise Harvesting Losses within the Queensland Sugar Industry. Proc. Aust. Soc. Sugar Cane Technol., 18:1-5.
- Markley, J, Raines, A, Langham, DA and Fleming, G, 2006. Harvest and Transport Integration – A Mackay Sugar Perspective, Proc. Aust. Soc. Sugar Cane Technol., 28, (CDROM, 7 pp).
- Marrero, S, Ponce, E, Guerrero, A, Sefton, M, Camacho, A, DiBella, L, DeLai, R and Girgenti, A 2010. Asset management and electronic assignment. Proc. Aust. Soc. Sugar Cane Technol., 32.
- Mattsson JE and Kofman PD 2002. Method and Apparatus for Measuring the Tendency of Solid Biofuels to Bridge Over Openings. Biomass and Energy, 22; 179-185.
- McCormack, R, Kerruish, W, Giles, R 2009. Harvesting Mallee Biomass - Some Options, Future Farming Industries CRC.
- McDonald, LM, Wood, AW and Muchow, R 2003. A Review of the Effect of Harvest Time on Sugarcane Productivity, Proc. Aust. Soc. Sugar Cane Technol., 21, 177-184.
- Milford, BJ 2002. Value Chains in the Australian Sugar Industry: An Assessment And Initial Study. Proceedings of the Australian Society of Sugar Cane Technologists, 24: 56-62.
- Muscat, J and Agnew, J 2004. Oakenden Harvesting Company Pty Ltd: Delivering Harvesting Best Practice. Proc. Aust. Soc. Sugar Cane Technol., 26, (CDROM, 7 pp).
- National Land and Water Resources Audit 2001b. Australian Water Resources Assessment 2000. Surface Water and Ground Water – Availability and Quality, Land and Water Australia, Canberra, Australian Capital Territory, p.160.
- National Land and Water Resources Audit. 2002. Australia's Natural Resources: 1997 – 2002 and Beyond, Land and Water Australia, Canberra, Australian Capital Territory, p.141.
- nitrogen management. Proc. Aust. Soc. Sugar Cane Technol., 26.
- Norris, CP, Davis, RJ and Hockings, PR 1999. Improving the Performance of Chopper Systems in Cane Harvesters. Bureau of Sugar Experiment Stations Publication SD99019, Brisbane, Australia.

Norris, CP, Davis, RJ and Poulsen, LS 1998. An Investigation Into the Feeding of Lodged Green Cane by Harvesters, *Proc. Aust. Soc. Sugar Cane Technol.*, 20: 224-231.

Norris, CP, Hockings, PR and Davis, RJ 2000. Chopper Systems in Cane Harvesters: A: Development of a Test Facility. *Proc. Aust. Soc. Sugar Cane Technol.*, 22:244–249.

Norris, CP, Robotham, BG and Tudroszen, NJ 2000. Harvest and Transport Considerations for Whole-Crop Harvesting in the Condong mill Area, Bureau of Sugar Experiment Stations Consultancy Report CO00016, Brisbane, Australia.

O’Keefe, M 1997. Supply Chain Management. *Agricultural Science*, May-June 1997:29-32.

Olsen, G, Cooper, D J, Huxtable, D, Carslake, J and Bartle, J R 2004. Search project final report, NHT Project 973849 – Developing Multiple Purpose Species for Large Scale Revegetation, CALM, Kensington, Western Australia.

Pearce, F 1994, Optimising Cane Harvester Extractor Performance. ME Thesis, Faculty of Engineering and Surveying, University of Southern Queensland, Toowoomba, Australia.

Peck A, Sudmeyer R, Huxtable D, Bartle J and Mendham D 2011. Productivity of Mallee Agroforestry Systems Under Various Harvest and Competition Management Regimes. Rural Industries Research and Development Corporation, Canberra.

Petheram, C., Zhang, L., Walker, G. and Grayson, R 2002. Towards a Framework for Predicting Impacts of Land-Use on Recharge: A Review of Recharge Studies in Australia, *Australian Journal of Soil Research*, Vol. 40, pp.397–417.

Pinkney, A. and Everitt, P 1997. Towards an Integrated Cane Transport Scheduling System. *Proc. Au Technol.*, 19: 420-425.

Powell, JG 2006. Wide-Swath Harvesting, Powerpoint Presentation – Wide-Swath Harvesting Workshop, Mackay, May 2006, Queensland Mechanical Caneharvesters Association.

Prestwidge, DR, Lamb, B, Higgins, AJ, Sandell, GR and Beattie, R, 2006. Optimising the Number and Location of New Cane Delivery Pads in the NSW region. *Proc. Aust. Soc. Sugar Cane Technol.*, 28, (CDROM, 10 pp).

QSL . 2011. Raw Sugar Supply Agreements rolled over until June 2015, Retrieved 25 October 2011).
Ridge DR and Hobson PA 1999, Removal Of Extraneous Matter In Sugar Mills For Co-Generation Of Power And Reduction Of Cane Loss, Bureau of Sugar Experiment Stations Publication SRDC Final Report SD99005, Brisbane, Australia.

Ridge, DR and Dick, RG, 1988. Current Research on Green Cane Harvesting and Dirt Rejection by Harvesters, *Proc. Aust. Soc. Sugar Cane Technol.*, 10: 19-26.

Ridge, DR and Dick, RG, 1992. Soil Intake with Cane during Chopper Harvesting – Minimising the Problem. *Proc. Aust. Soc. Sugar Cane Technol.*, 14:24–30.

Ridge, DR and Linedale, AL, 1997. Targeting High Soil Levels in Cane. *Proc. Aust. Soc. Sugar Cane Technol.*, 19:44–50.

Ridge, DR and Norris, CP, 2000. Harvesting and Transport, Chapter 16 in *Manual of Canegrowing*, DM Hogarth and PG Allsopp (eds), Bureau of Sugar Experiment Stations, Brisbane.

- Ridley, AM., Pannell, DJ., Ewing, ME. and Lefroy, E 2004. 'The role of plants and plant-based R&D in managing dryland salinity in Australia', in Ridley, A., Feikema, P., Bennet, S.,
- Robinson, N, Harper, RJ, and Smettem, KRJ .2006. Soil Water Depletion by Eucalyptus Ssp Tree Belts Integrated into Dryland Agricultural Systems. *Plant and Soil* 286, 141-151.
- Robotham, BG, Norris, CP and Geddes, RG 2001. Upgrading Load and Speed Limits for Cane Transport Vehicles, Sugar Research and Development Corporation Project BSS190, BSES Publication SD01004.
- Ruxton, Adam, and Grabau, PJ 2009. Automating Harvester and Haulout Forward Progression During Harvesting RTK-GPS. *Proceedings of the Australian Society of Sugar Cane Technologists*, 31. pp. 355-364. ISSN 0726-0822
- Sandell, GR and Agnew, JR 2002. The Harvesting Best Practice Manual for Chopper-Extractor Harvesters. Bureau of Sugar Experiment Stations, Brisbane, Australia.
- Sandell, GR and Prestwidge, DB 2004. Harvest Haul Model – The Cost of Harvesting Paddocks of Sugarcane Across a Sugar Milling Region. *Proc. Aust. Soc. Sugar Cane Technol.*, 26, (CDROM, 10 pp).
- Schembri, M 2000. Commercial Implementation of the Crop Divider Height Control System. Sugar Research and Development Corporation Project SRI092 Final Report, Brisbane, Australia
- Schembri, MG and Garson, CA 1996. Gathering of Green Cane by Harvesters: A First Study, *Proc. Aust. Soc. Sugar Cane Technol.*, 18:145-151.
- Schembri, MG, Hobson, PA and Paddock, R 2002. The Development of a Prototype Factory-Based Trash Separation Plant. *Proc. Aust. Soc. Sugar Cane Technol.*, 24: 12-18.
- Schembri, MG, McKenzie, NJ, Connor, A and Everitt, PG 2000. Further Advances in Automating Basecutter Height Control. *Proc. Aust. Soc. Sugar Cane Technol.*, 22:92-97.
- Schroeder, B, Panitz, J, Linedale, T, Whiteing, C, Callow, B, Samson, P, Hurney, A, Calcino, D, and Allsopp, P 2009. SmartCane Harvesting and Ratoon Management. SmartCane Best Management Practice Booklet. BSES Limited Technical Publication TE09004. ISBN: 978-0-949678-32-4.
- Shaw, GR and Brotherton, GA 1992. Green Cane Harvesting – A Dilemma, *Proc. Aust. Soc. Sugar Cane Technol.*, 14: 1-7.
- Sichter, NJ, Whiteing, C and Bonaventura, P 2005. Estimation of Harvester Losses by Determination of Sugar in Harvest Residue, *Proc. Aust. Soc. Sugar Cane Technol.*, 27, (CDROM 7pp).
- Spinaze, D H 2002. A Harvester-mounted Trash Shredder and Collection System. *Proc. Of Aust Soc. of Sugar Cane Technol.* 12 , 63-66.
- Spinaze, D and Subramanian, C 1999. Surface Engineering of Basecutter Blades to Reduce Wear. *Proc. Aust. Soc. Sugar Cane Technol.*, 21:191-195.
- Stewart, RL and McComiskie, G 1988. A Comparison of Green and Burnt Cane Harvesting in the Burdekin, *Proc. Aust. Soc. Sugar Cane Technol.*, 10: 27-32.
- Sugar Industry Oversight Group 2006. The Strategic Vision for a Commercially Vibrant Sustainable and Self-Reliant Industry in Australia.

Sugar Research and Development Corporation, SRDC 2004. Cane Harvesting to Improve Industry Performance, Sugar Research and Development Corporation Technical Report 2/2004, Brisbane, Australia.

Sugar Research and Development Corporation, SRDC 2006. Analysis of Bagasse and Trash Utilisation Options, Sugar Research and Development Corporation Technical Report 2/2006, Brisbane, Australia.

Sugar Research and Development Corporation, SRDC 2006 (b). The Value Chain of the Australian Sugar Industry. SRDC Technical Report 1/2006. ISSN 1327-9475. Brisbane

Sutherland, RF 2002. New Energy Options in the Australian Sugar Industry. Proc. Aust. Soc. Sugar Cane Technol., 24: 19-23.

Thorburn, P, Hobson, P, Higgins, A, Juffs, R and Downs, P 2006. Integrated Value Chain Scenarios for Enhanced Mill Region Profitability. Final Report Project Report CSE010. Sugar Research and Development Corporation.

Turner, N and Ward, PR 2002. Special Issue: The Role of Agroforestry and Perennial Pasture in Mitigating Waterlogging and Secondary Salinity, Agricultural Water Management, Vol. 53, p.275.

URS Australia.2008. Oil Mallee Industry Development Plan For Western Australia. Report for the Oil Mallee Association of Australia Inc and the Forest Products Commission of WA. URS Australia Pty Ltd, November 2008

Watson LJ and Connors CG 2008. Furfural—A Value Adding Opportunity for the Australian Sugar Industry. Proc of Aust Soc Sugar Cane Technol. Vol 30

Whiteing CNC 2001. Extraneous Matter V's Cane Loss; Finding a Balance in Chopper Harvested Green Cane. *Proc of 24th ISSCT*.

Whiteing, C and Kingston, G 2008. Regional Adoption of Alternative Harvester Configurations for Sustainable Harvesting Efficiency, Bureau of Sugar Experiment Stations Publication SD 08005, Brisbane, Australia.

Whiteing, C, Norris, CP and Paton, D 2002. Facilitation of Best Practice to Reduce Extraneous Matter and Cane Loss. Bureau of Sugar experiment Stations Publication SD02009, Brisbane, Australia.

Whiteing, C, Norris, CP and Paton, DC 2001. Extraneous Matter versus Cane Loss: Finding a Balance in Chopper Harvested Green Cane. Proc. Intl. Soc. Sugar Cane Technol., 24(2):276-282.

Wildy, D, Pate, J and Bartle, J 2003. Silviculture and Water Use of Short-Rotation Mallee Eucalypts, RIRDC Publication No 03/033, Rural Industries Research and Development Corporation, Canberra

Willcox TG, Crane J and Downs P 2005. Measurement and Feedback Systems for Improving Market Signals for Harvesting, Final Report - SRDC Project BSS261, BSES Ltd.

Willcox, T, Hussey, B, Chapple, D and Kelly, R 2004. Working Towards Payment Methods for Harvesting that Provide Incentive for Good Farming Practice, Proc. Aust. Soc. Sugar Cane Technol., 26, (CDROM, 7 pp).

Willcox, TG, Juffs, R, Crane, J and Downs, P 2005. Measurement and Feedback Systems for Improving Market Signals for Harvesting, Sugar Research and Development Corporation Project BSS261 Final Report SD05013, Brisbane, Australia.

Wright PG, Fernandes AC and Zarpelon F 2007. Control Calculations for Factories Producing Both Sugar and Alcohol. *Proc. Aust. Soc. Sugar Cane Technol.*, Vol. 29

Wu H, Fu Q, Giles R, and Bartle J 2008. Production of mallee biomass in Western Australia: energy balance analysis. *Energy and Fuels*, 22, 190-198

Wu H, Hendrawinata W, Yu Y, Gao X, Li Y, Bartle J and Grayling P. 2011. Effect of hydrodistillation on 1,8-cineole extraction from mallee leaf and the fuel properties of spent biomass. *Industrial and Engineering Chemistry Research*, 50, 11280-11287.

Yun Yu, Bartle, J, Chun-Zhu Li and Hongwei Wu 2009. Mallee Biomass as a Key Bioenergy Source in Western Australia: Importance of Biomass Supply Chain. *Energy & Fuels* 2009, 23, 3290–3299.

Zillman, SR and Harris, HD 2001. Developing and Improving the Jetclean Harvester Cleaning System. Sugar Research and Development Corporation Project NCA006 Final Report, Brisbane, Australia.

Sustainable Biomass Supply Chain for the Mallee Woody Crop Industry

Pub. No. 12/O22

This report provides a pre-feasibility assessment of the mallee woody crop supply chain based on a comparative assessment with the sugar supply chain. The report will assist in developing a sustainable supply chain for the mallee industry.

The report is targeted at the stakeholders of the mallee woody crop industry. Stakeholders include seedling nurseries and contract tree planters, farmers, harvesting contractors, road transport operators, biomass processors and conversion industries, consumers of the products from conversion industries, CRC, university and public sector industry development workers and private sector industry development individuals and corporations other than farmers.

RIRDC is a partnership between government and industry to invest in R&D for more productive and sustainable rural industries. We invest in new and emerging rural industries, a suite of established rural industries and national rural issues.

Most of the information we produce can be downloaded for free or purchased from our website <www.rirdc.gov.au>.

RIRDC books can also be purchased by phoning 1300 634 313 for a local call fee.



RURAL INDUSTRIES

Research & Development Corporation

Phone: 02 6271 4100

Fax: 02 6271 4199

Bookshop: 1300 634 313

Email: rirdc@rirdc.gov.au

Postal Address: PO Box 4776,
Kingston ACT 2604

Street Address: Level 2, 15 National Circuit,
Barton ACT 2600

www.rirdc.gov.au