

Automation and Control in Surface Irrigation Systems: Current Status and Expected Future Trends

Richard Koech*, Rod Smith and Malcolm Gillies

CRC Cotton Catchment Communities and National Centre for Engineering in Agriculture
University of Southern Queensland, Toowoomba
Toowoomba, Australia

*Corresponding and presenting author, koech@usq.edu.au

Abstract—Surface irrigation systems are the most popular methods for irrigating crops and pastures not only in Australia but the world over. However, these systems are often labour intensive and exhibit low water use efficiency. Rising labour costs especially in the developed world and competition for scarce water resources have generated renewed interest in the automation of surface irrigation systems.

This paper provides a comprehensive review of the current level of automation and control of surface irrigation systems. The automation techniques discussed utilise various devices including mechanical, electronic, pneumatic and hydraulic means. The use of telemetry is also discussed. With the almost universal access to high performance computers and fast internet, the concept of real-time control in surface irrigation is not far-fetched. Towards this end, an on-going research project at USQ aimed at modernising furrow irrigation by use of automatic control systems in real time is discussed.

Keywords- Automation, real-time control, surface irrigation

I. INTRODUCTION

Surface irrigation (furrow, basin and bay) is a method of irrigation in which water is conveyed on the surface across field by gravity flow while at the same time infiltrating into the soil. Surface systems are the most common in Australia and much of the world. In 2008-09, surface irrigation accounted for 63% of the total irrigated land in Australia, the majority of which is located in the Murray-Darling Basin (ABS 2010).

In furrow irrigation, one of the oldest known techniques of surface irrigation, water is conveyed through small channels with a gentle slope towards the downstream end. The spacing of these channels generally correspond to the spacing of the crop to be established. This method is popular for the irrigation of row crops. As opposed to furrows, basins are designed to be level in all directions and can be square or rectangular in shape. Earthen banks are constructed around the basin leaving a notch for water inlet. The system has traditionally been used to grow rice. Bays are similar to basins, but have a slight slope and free draining conditions at the downstream end. Bay irrigation is the preferred method for the irrigation of pastures in southern Australia.

Surface systems are simple, have low energy consumption and require comparatively low initial capital. However, they are often associated with a high labour requirement and low water use efficiency (e.g. Smith et al. 2005). Rising labour costs, the competition for water and the need to conserve the

environment has intensified the move to more advanced systems. Automation is one means of ameliorating the problems of high labour requirement and low water use efficiency of surface systems. But the spatial and temporal variability of the soil infiltration characteristics means that each irrigation behaves differently and are therefore difficult to standardise and automate (Walker 1989).

Apart from on-farm automation, many irrigation areas especially in the southern part of Australia have or are developing automated water delivery systems. The integration of on-farm and channel control technologies will become a real possibility in the near future. Some of these developments in the irrigation industry have benefited from the Australian Federal and State governments' financing with a precondition that the water saved be surrendered back to the environment (Plusquellec 2009).

The purpose of this paper is to review the current status of automation of surface irrigation in Australia. An on-going research project at USQ aimed at modernising furrow irrigation through automation and use of adaptive real-time control is also described.

II. AUTOMATION AND CONTROL IN SURFACE IRRIGATION SYSTEMS

A. Equipment

A number of surface irrigation automation and control devices are available in Australia, the majority of which are manufactured locally. These range from gates that are commonly used to control the flow of water to an irrigation bay or basin, to water sensors, and to telemetry and supervisory control and data acquisition (SCADA) systems. The most commonly used systems are described below.

Gates and flow metering: Gates are structures placed in an irrigation channel or bay/basin outlet to control the flow of water. The control of these devices may be achieved by a mechanical timer or electric solenoid. In Australia, existing manually controlled gates are being automated (Mareels et al. 2005). Commercially available gates widely used in the Australian irrigation industry and their mode of actuation are summarised in Table 1.

Dethridge Wheels have traditionally been used in Australia to measure the flow of water from the supply system onto the

Table 1: Commercially available channel/outlet gates

Gate	Manufacturer	Features	Mode of control
Rubicon SlipGate	Rubicon Systems Australia	Can measure flow when fitted with sensors	Electromechanical actuators
FlumeGate™	Rubicon Systems Australia	Control and measure flow	Electromechanical actuators
Padman stop	Padman Stops	Rubber set in concrete structure	Mechanical timer
Water control gates (various)	AWMA Pty Ltd.	Actuation systems are custom made	Manual, electromechanical, hydraulic or pneumatic actuators

farm, but are increasingly being replaced by a variety of modern ultrasonic and electromagnetic meters (Smith and Nayar 2008).

Advance sensors: Irrigators often use their intuition and experiences to determine the time to cut-off water flow into an irrigation bay/ basin or furrow. In bay irrigation for instance, the inflow is commonly cut-off when the water front reaches two thirds of the distance down the bay (Dassanayake et al. 2009).

Sensors that are now routinely used in surface irrigation in Australia include Irrimate™ water sensors, Padman radio bay sensors and Padman pneumatic bay sensors. Irrimate™ advance sensors, commonly used in the evaluation of furrow irrigation, are placed at various points along the length of the field and are triggered by the advancing water front. The advance times are downloaded to a hand-held computer after the irrigation event. Padman radio bay sensors are placed at predetermined point along the irrigation bay. They are triggered by the advancing water and the signal is sent via radio links to the bay gate to cut-off the inflow. Pneumatic bay sensors are connected to the automatic gates by air-filled pipes. When the advancing water enters the sensor the air inside the pipe is pressurised thereby activating the opening and closing of the automatic gates (Armstrong 2008). A remote sensing vision system comprising a camera placed at the field boundary is described by Lam et al. (2007). There is however no evidence that such a system has been used at a commercial scale.

Telemetry systems: Telemetry systems are vital components of automatic surface irrigation methods. They allow measurement of various parameters from a remote location and the results are conveyed to a central location via wireless means such as radio, telephone, infrared, satellite and internet. The telemetry technology commonly used in automated surface irrigation systems is the SCADA system (Smith and Nayar 2008; Armstrong 2009). The AWMA Aquator system (mainly used to control bay/basin outlets), and Rubicon's Total Channel Control (used to control channel flow), both use SCADA platform and allow remote control of these devices.

B. Bay and basin Irrigation

Typical bay and basin systems have head ditches at one edge of the field which are fed from open channels. Initial attempts to automate these systems appear to have focussed on controlling the inlets or gates that supply water to the field. Gates with a single function (either open to admit water or shut off the flow) are described in Humpherys (1995a) while dual function gates (open and close) are detailed in Humpherys

(1995b). The control of these devices may be achieved by a mechanical timer or electric solenoid, that is, they are time-based open-loop systems (Humpherys 1995c). However, the two types of gates require resetting prior to the next irrigation event. A time-based control basin system using off-the-shelf sprinkler controller to control the gate is described in Niblack and Sanchez (2008).

AWMA Pty Ltd., a company based in Australia has developed the 'Aquator' system which combines the technology of radio telemetry, solar power and personal computers to automate and control bay and basin outlets (AWMA 2009). Aquator uses the SCADA platform and the software is installed in a personal computer stationed in a house or office (base station). The operation commands from the base station are sent out to the outlets to be controlled through a base transmitter connected to the computer and aerial installed on the roof. The outlets to be controlled have radio receivers, control electronics and aerials, and are mostly solar-powered.

The time to cut off flow in time-based control systems is mainly based on the irrigator's experience and intuition. But the spatial and temporal variability of soil infiltration characteristics (Smith et. al. 2009; Gillies 2008; Walker 1989; Emilio et al. 1997) means that the advance time will also be variable from one part of the field to the next and from one irrigation to the next (Humpherys and Fisher 1995). The essence of feedback control is to give a better estimate of the advance time (and therefore the most appropriate time to cut off) through the measurement of the advance rate with the ultimate aim of improving water use efficiency.

Feedback control in automated bay and basin irrigation systems typically involves the use of sensors placed near the downstream end of the field (for example Clemmens 1992, Niblack and Sanchez 2008, and Humpherys and Fisher 1995). The sensors are triggered by the advancing water front to send a signal by telemetry to the gates to cut off the flow (Niblack and Sanchez 2008, and Humpherys and Fisher 1995). Feedback from sensors can also be used to continually adjust the flow rate (Clemmens 1992).

C. Furrow Irrigation

In furrow irrigation, small channels or furrows spaced according to the row spacing of the crop to be established (typically about 1 m) are used to convey irrigation water from the inlet to the downstream end of the field. The water is supplied from a head ditch or gated pipe that runs along one edge of the field. Overbank siphons, pipes through the bank (PTBs) and bankless channels are all different means used to

transfer water from the head ditch into the furrows, with the former being the most predominant. A PTB is typically about 300 mm internal diameter buried underneath the bank facing the field to be irrigated and delivers water to a group of furrows. Bankless channel systems are relatively new to Australia (Graham et al. 2008), and as the name suggests, the head ditch in this case has no bank on the field side. The paddock is subdivided into separate bays which may be level or with a small slope upwards away from the channel. Gates installed in the channel are used to block the water forcing it to flow into each bay in turn. Notched lined head ditches, very rarely used in Australia, have been used to supply water to furrows in the US (Humpherys 1969).

Distributing water uniformly into individual furrows without the use of expensive structures and devices presents a major challenge in the automation of furrow irrigation (Humpherys 1969). For this reason, furrow systems have seen very little mechanisation and automatic control as compared to other surface irrigation techniques. Previous efforts at automation of furrow system include surge flow (Walker 1989; Lier et al. 1999; Humpherys 1989; Mostafadeh-Fard 2006), automatic cutback (Humpherys 1969) and cablegation (Kemper *et al.* 1987). Furrow systems involving the use of microcomputer and telemetry are described in Hibbs et al. (1992) and Lam et al. (2006).

Hibbs et al. (1992) developed a furrow irrigation automation system utilising an adaptive control algorithm (FAAC) in which water is delivered to a block of furrows and the outflow was monitored using a flume and a depth sensor installed at the downstream end of the furrow. The infiltration characteristics were analysed by a microcomputer and the inflow is adjusted accordingly by using an automatic valve. The inflow system employs an adjustable pressure regulator and a diaphragm valve to supply equal inflow rates among a block of furrows. However, outflow is only monitored from selected representative furrows. While it might be infeasible to monitor outflow from each furrow, errors will inevitably be introduced into the system because of spatial variability of the infiltration characteristics across the field. Application efficiencies of the FAAC irrigations were found to be higher than those of conventional systems (Hibbs et al. 1992). However, the system is based on the outflow hydrograph, and it is not always practical to obtain accurate measurements of outflow using a flume.

Surge flow irrigation is achieved by intermittent application of water to furrows, as opposed to the conventional continuous flow. Two commercially available surge flow irrigation systems are described by Walker (1989). The 'dual line' system commonly used by irrigators who already have gated pipe system in place, uses an automated surge flow valve to switch the flow between the two sides of the pipe system. In the 'single line' system, each outlet of the gated pipe is fitted with a valve. These valves are grouped into a suitable number and controlled from a central location to achieve a surge flow pattern. Mostafadeh-Fard (2006) designed an automatic surge flow irrigation system using wireless, cheap programmable surge valves installed in a gated pipe and use solar-powered batteries. The control mechanism consisted of an electronic board, motor and gear, and solar battery. Notwithstanding the merits of the surge system, the method is generally seen as complex and the cost of implementation may be too high. The use of rigid gated pipes

in surge flow systems is also unlikely to endear to many irrigators because of transportation difficulty.

Cablegation is an automatic furrow irrigation technique which uses a travelling plug inside a gated pipe system. Water application is restricted to only those gates nearest to the plugs, and the flow into any furrow gradually decreases as the plug moves further downstream. Although cablegation has a number of advantages including labour savings and potential reduction in runoff, it was found to be unable to compensate for the furrow-to-furrow variability in intake rate (Kemper et al. 1987).

None of these designs has been widely adopted by irrigators because of the initial cost and their perceived complexities.

Automation of overbank siphons has so far proved infeasible. An interesting fairly recent development is the use of a motorised priming unit to start up large overbank siphons (SPACEPAC 2010). The majority of the PTBs in use in the cotton industry have a flap valve and an extended arm at the inlet point in the head ditch side of the bank used to control flow (Fig. 1). The opening and closing is often done manually, but there is a great potential for automation. This was demonstrated at a furrow irrigation automation trial site in the Gwydir Valley (Fig. 2) whereby each PTB inlet mechanism was automated allowing remote control using the 'Aquator' system (AWMA 2009).

III. IMPACT OF AUTOMATION AND CONTROL IN SURFACE IRRIGATION SYSTEMS

A. Benefits

In automated surface irrigation systems, the irrigation process takes place in the absence of the irrigator (or operator). The excess labour as a result of automation can be re-deployed elsewhere in the farm or simply dispensed with. The irrigator will have more time to engage in other activities or relax. This partly explains why the benefits of automation have traditionally been seen as labour saving and lifestyle improvement, especially from the point of view of the irrigators.

The use of automatic structures and devices in irrigation guarantees timely farm operations (such as opening and closing of inlet bay structures) and eliminates (or at least reduces) the element of human error. This leads to water savings, the magnitude of which depends in part on the robustness of the control strategy in place.

That the water saving aspect of automation is somehow obscure is perhaps best illustrated by a survey undertaken by Maskey et al. (2001). When asked about their perceptions of the benefits of automation, the percentage of farmers who considered labour saving and reduction of water usage as having the greatest benefits were 59% and 19.3% respectively. The potential increase of land value as a result of automation was also widely recognised by the farmers.

Few researchers have attempted to quantify the benefits of automation in irrigation projects. Lavis et al. (2007) estimated water saving of 5 to 9% in the Shepparton Irrigation Region. Initial results from a bay irrigation project using an intelligent irrigation controller and wireless sensor network at Dookie, Northern Victoria, suggest that an average water saving of 38% can be realised (Dassanayake et al. 2009).



Figure 1. Manually operated PTB.



Figure 2. Automated (PTBs) for furrow irrigation.

B. Level of Adoption

There is limited published data on the percentage of irrigators who have adopted some form of irrigation automation in Australia. However it is clear that the majority of the automated systems are found in southern-eastern Australia (New South Wales, Victoria) and particularly within the dairy industry. Bay irrigation is the preferred method of irrigation in these areas. Statistics from Murray Valley Irrigation Area (Maskey et al. 2001) and Central Goulburn in Northern Victoria (Armstrong 2008) indicate that 8% and 11% of dairy farmers respectively were using some form of automation in their farming practices.

C. Barriers

Walker and Skogerboe (1987) cited lack of interest by potential manufacturers in investing in the design and manufacture of automation infrastructure because of perceived weak market. The low adoption of automation technologies was thus attributed to the scarcity and therefore expense of automation equipment. The survey of irrigators in the Murray Valley Irrigation Area (Maskey et al. 2001) rated automation equipment cost as the most important barrier to automation. The irrigators also added other priorities in the farm and the requirement of the farm re-design before automation as important barriers to automation. More manufacturers are expected to come onto the market as more irrigators adopt the new technology. This will inevitably lead to lower retail prices.

D. Future Trends

The future will undoubtedly face more competition for the already scarce water resources. Governments and environmentalists will continue to advocate for a balance between the exploitation of water resources and sustainable environmental conservation. All water users, including irrigators, will be required to be more accountable in their use of the scarce resource. Farm labour will become scarce and expensive. It is widely anticipated that some of the farms presently under surface irrigation will eventually be converted to the various forms of low-pressure systems, but nonetheless surface irrigation will remain a dominant method for the

foreseeable future (for example Gillies 2008; Raine 2006). It is likely that the current efforts to modernise and improve the water use efficiencies of the surface systems will intensify in the future.

Several factors work in favour of the surface systems, the initial capital requirement perhaps being the most significant. Most surface systems are gravity-fed with very limited piping. The limited pumping involved means that the energy requirements (and therefore the carbon foot print) are also low. There is also the advantage of low maintenance cost involved and the use of generally unskilled labour.

The conversion from surface to pressurised systems comes with a heavy initial capital investment. This investment cannot always be justified, as shown by a study of the dairy industry in the Lower Murray-Darling Basin (Doyle et al. 2009). This study concluded that adopting pressurised irrigation systems will not improve the viability of most irrigated dairy farms as the farmers need time to acquire a new set of skills. Wood and Martin (2000) also advised against the broad adoption of pressurised irrigation systems as the benefits were not automatic. Pressurised systems also rely heavily on energy, the price of which has been on a steady increase for several decades. The possibility of energy prices increasing to the point of rendering the pressurised systems unviable is not impossible.

We take the view that the research and improvement of surface systems will continue into the future. This will deliver performance similar to the pressurised systems at a lesser cost. But as with any new technology, automation and especially the use of telemetry, will take some time before irrigators can adopt in a broader scale.

IV. AUTOMATION AND REAL TIME CONTROL OF FURROW IRRIGATION

An on-going project at the University of Southern Queensland (USQ) aims to develop, prove and demonstrate an automated furrow irrigation employing adaptive real-time control. Hardware and software devices and systems will be utilised to automatically divert the desired amount of water to

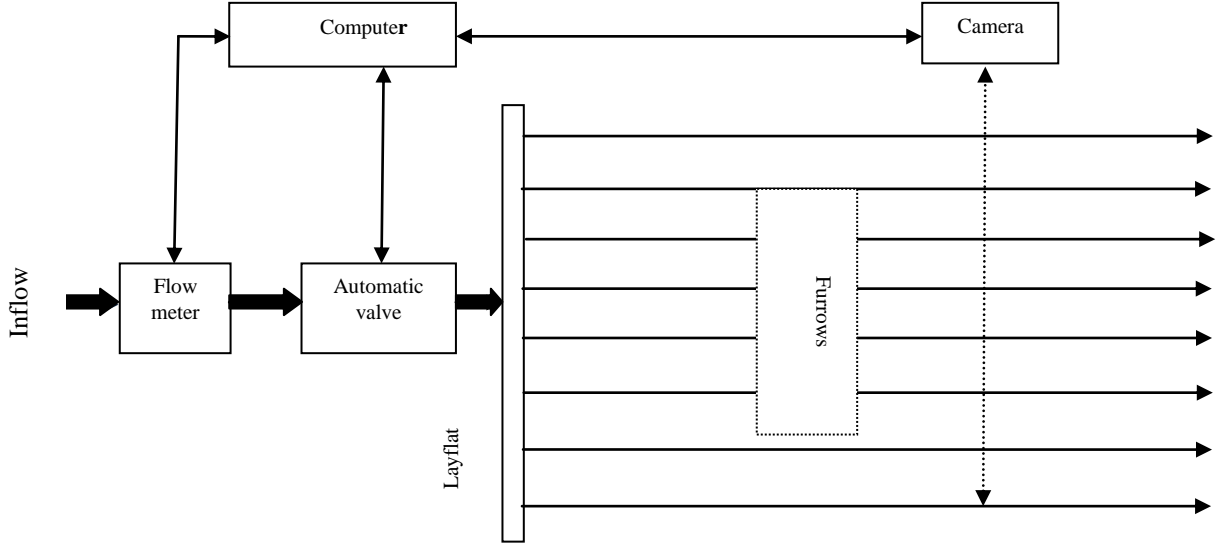

Figure 3. Real-time control system layout for furrow irrigation

furrows to satisfy the water requirements of a growing crop. Real-time adaptive control will be utilised, enabling the use of data collected during the irrigation being managed to control that particular irrigation to give optimum performance for the current soil conditions. The proposed system is expected to deliver irrigation performance similar to the pressurised systems along with similar labour savings but at greatly reduced capital and energy costs.

A. Conceptual design of a real-time control system for furrow irrigation

The conceptual design of an automatic furrow irrigation system using adaptive real-time control (Fig. 3) consists of the water delivery system, a computer and a camera placed close to the tail-end of the furrow. Water is delivered into individual furrows using gated layflat fluming. The camera is interfaced with a radio modem, enabling the images of the advancing water (taken across furrows) to be sent to the computer by wireless means. The computer then evaluates the infiltration characteristics through a simulation process and determines the optimum time to cut-off the inflow. The inflow into the set of furrows is switched off using an automatic valve. The system then commences irrigating the next set of furrows.

B. Model Description

A simulation model suitable for an automatic furrow irrigation using adaptive real-time control must be able to obtain reliable infiltration estimates in the shortest time possible and use the results to optimise that particular irrigation event. The basis for this type of system was proposed by Khatri and Smith (2006) who hypothesised that the shape of the infiltration characteristic for a particular field or soil is relatively constant despite variations in the magnitudes of the infiltration rate or depth of infiltration. The amount of data required for the prediction of the soil infiltration characteristics are reduced by scaling the infiltration parameters from an infiltration curve of known shape (model infiltration curve) and one advance point measurement in the furrow.

An appropriate infiltration equation such as the Kostiakov-Lewis is used to estimate the infiltration characteristics:

$$I = k\tau^a + f_o\tau \quad (1)$$

where I is the cumulative infiltration (m^3/m), τ is the time (min) from the commencement of infiltration, k ($\text{m}^3/\text{min}^a/\text{m}$) and a (non-dimensional) are fitted parameters and f_o ($\text{m}^3/\text{min}/\text{m}$) is the steady or final infiltration rate. A representative furrow in the field is selected and evaluated over an irrigation event, and the model infiltration curve is obtained using the Kostiakov-Lewis equation.

In this method a scaling factor (F) is formulated for each furrow or event from a re-arrangement of the volume balance model (as used by Elliot and Walker (1982)):

$$F = \frac{Q_o t - \sigma_y A_o x}{\sigma_z k t^a x + \frac{f_o t x}{1+r}} \quad (2)$$

where Q_o is the inflow rate for the corresponding furrow (m^3/min), A_o is the cross-sectional area of the flow at the upstream end of the field (m^2), t is the time (min) for the advance to reach the distance x (m) for the corresponding furrow, σ_y (dimensionless) is the surface storage shape factor, and σ_z (dimensionless) is the sub-surface shape factor and is defined as:

$$\sigma_z = \frac{a + r(1-a) + 1}{(1+a)(1+r)} \quad (3)$$

where r is the exponent from the power curve advance function $x = p(t)^r$ for the model furrow.

The scaling factor is then applied to the Kostiakov-Lewis equation to obtain the scaled infiltration curves for the whole field:

$$I_s = F(k\tau^a + f_o\tau) \quad (4)$$

where I_s is the scaled infiltration (m^3/m), a , k , f_o are the infiltration parameters of the model furrow.

The scaled infiltration characteristics obtained from this approach are then used in a simulation and optimisation process to determine the time to cut-off the inflow.

Component software and data to be integrated within the adaptive controller system include:

- continuous inflow measurement through inference from pressure measurements in the layflat fluming using the Gpipe program based on Smith (1990),
- pre-characterisation of the field by determining a generic soil infiltration characteristic from detailed measurements of single irrigation events,
- real-time prediction of the infiltration parameters from a single observation of the irrigation advance during the irrigation event being controlled (Khatri and Smith 2006), and
- simulation of the irrigation and optimisation to determine the preferred time to cut off the inflow to the field using the SISCO simulation engine (Gillies et al. 2010) and taking into account the current soil moisture deficit and the variation in the infiltration characteristic across the set of furrows.

V. CONCLUSIONS

Surface irrigation systems are the most popular for the irrigation of row crops and pasture. In Australia these systems are used on more than half of the total irrigated land. Compared to the pressurised systems however, surface systems are more labour intensive and often exhibit lower water use efficiencies.

The improvements of the surface systems through automation began several decades ago. These improvements appear to have been biased towards bay and basin systems and initially focussed on on-farm flow control by use of gates. The state of the art of the surface systems in the Australian irrigation industry has been presented. Notable recent addition is the use of telemetry such as the SCADA technology.

This paper has argued that the current development in the surface systems will be sustained into the future, and that these systems will continue to dominate for many years to come. The wide range of automation equipment and software tools commercially available in Australia has removed a major barrier to adoption.

The on-going research project at USQ focuses on the furrow system which is the preferred method for the irrigation of cotton in Australia. The project aims to develop, prove and demonstrate an automated furrow system employing adaptive real-time control. The goal is to upgrade the performance of the furrow system to be at par with the pressurised systems with similar labour savings but at greatly reduced capital costs.

REFERENCES

- ABS. 2010, 'Water use in Australian Farms, 2008-09', *Australian Bureau of Statistics*.
- Armstrong, D. 2009, 'Modelling dairy farming systems', *Technical Bulletin*, The State of Victoria, Department of Primary Industries.
- AWMA 2009, 'Aqator Automated Irrigation', viewed 12 May 2009, <<http://www.awma.au.com>>.
- Clemmens, A. J. 1992, 'Feedback control of basin irrigation system', *Journal of Irrigation and Drainage Engineering*, 118(3), 481-496.
- Dassanayake, D, Dassanayake, K, Malano, H, Dunn, G. M, Douglas, P and Langford, L 2009, 'Water saving through smarter irrigation in Australian dairy farming: Use of intelligent irrigation controller and wireless sensor network', *18th World IMACS / MODSIM Congress*, Cairns, Australia 13-17 July 2009.
- Doyle, P, Gibb, I and Ho, C 2009, 'Review of relevant information on potential productivity gains from on-farm irrigation technology', *Report prepared for Dairy Australia by Murray-Darling Basin Inquiry*.
- Elliott, R. L. and Walker W. R. 1982. 'Field evaluation of furrow infiltration and advance functions,' *Trans. of the ASABE*, 25(2), 396-400.
- Emilio, C., Carlos, P. L., Jose, R. C. and Miguel, A. 1997, 'IPE: Model for Management and Control of Furrow Irrigation in Real Time', *Journal of Irrigation and Drainage Engineering*, 123(4), 264-9.
- Gillies, M. H. 2008, 'Managing the effect of infiltration variability on the performance of surface irrigation', *PhD Thesis*, University of Southern Queensland, Toowoomba.
- Gillies, M. H., Smith, R. J., Williamson, B. and Shanahan, M. 2010. 'Improving performance of bay irrigation through higher flow rates', *Australian Irrigation Conference and Exhibition*, Sydney, 8-10 June 2010.
- Graham, M. K., Hornbuckle, J. W., Raine, S. R and Smith, R. J. 2008, 'Observations from initial evaluation trials of bankless channel irrigation systems', *Irrigation Association of Australia National Conference*, Melbourne, 20-22 May 2008.
- Hibbs, R. A, James, L. G and Cavalieri, R. P 1992, 'A furrow irrigation automation system utilizing adaptive control', *Trans. of the ASABE*, 35(3), 1063 -1067.
- Humpherys, A. S. 1969, 'Automation of Furrow Irrigation Systems', *Trans. of the ASABE*, 14(3), 460-470.
- Humpherys, A. S. 1989, 'Surge Irrigation: 1. An Overview', *ICID BULLETIN*, 38(2), 35-48
- Humpherys, A. S. 1995a, 'Semi-automation of irrigated basins and borders: I. Single function turnout gates', *Trans. of the ASABE*, 2(1), 67-74.
- Humpherys, A. S. 1995b, 'Semi-automation of irrigated basins and borders: II. Dual-function turnout gates', *Trans. of the ASABE*, 2(1), 75-82.
- Humpherys, A. S. 1995c, 'Semi-automation of irrigated basins and borders: III. Control elements and system operation', *Trans. of the ASABE*, 11 (1), 83-91.
- Humpherys, A. S. and Fisher, H. D. 1995, 'Water sensor feedback control system for surface irrigation', *Trans. of the ASABE*, 2(1), 61-65.
- Kemper, W. D, Trout, T. J. and Kincaid, D.C. 1987, 'Cablegation: Automated supply for surface irrigation.'

- Advances in irrigation*, D. Hillel. ed., Academic Press Inc., London, 1-66.
- Khatri, K. L. and Smith, R. J. 2006, 'Real time prediction of soil infiltration characteristics for the management of furrow irrigation', *Irrigation Science*, 25, 33-43.
- Lam, Y. S., Wallender W. W. and Upadhyaya, S. K. 2006, 'Computer Vision System for Automatic Control of Precision Furrow Irrigation System', *Trans. of the ASABE*, 50(2), 371-8.
- Lavis, A, Maskey, R and Lawler, D 2007, 'Quantification of farm water savings with automation', Department of Primary Industries, Victoria.
- Mareels, I, Weyer, E., Ooi, S. K., Cantoni, M., Li, Y. and Nair, G. 2005, 'Systems engineering for irrigation systems: successes and challenges', *Annual Reviews in Control*, 29, 191-204.
- Maskey, R, Roberts, G and Graetz, B 2001, 'Farmers' attitudes to the benefits and barriers of adopting automation for surface irrigation on dairy farms in Australia', *Irrigation and Drainage Systems*, 15, 39-51, 2001.
- Mostafazadeh-Fard, B., Osroosh, Y. and Eslamian, S. 2006, 'Development and evaluation of an automatic surge flow irrigation system', *Journal of Agriculture and Social Sciences*, 2(3), 129-32.
- Niblack, M. and Sanchez, C. A., 2008, 'Automation of surface irrigation by cut-off time or cut-off distance control', *Trans. of the ASABE*, 24(5), 611-614.
- Plusquellec, H. 2009, 'Modernization of large-scale irrigation systems: is it an achievable objective or a lost cause?' *Irrigation and Drainage*, 58: 104-120.
- Raine, S. R. 2006, 'The Future of Irrigation Technologies and Practices is Here Now', Keynote address. In "*Irrigation Australia 2006 Conference*". Brisbane.
- Smith, R. J. 1990, 'The distribution of water from rigid and lay-flat gated pipe. *Proc Australian Society of Sugar Cane Technologists 1990 Conference*, Townsville, p. 56-64.
- Smith, M. and Nayar, M. 2008, 'The first stage of Coleambally Water Smart Australia Project: Building on CICL's adoption of Total Channel Control (TCC)', *Irrigation Australia National Conference and Exhibition*, 20-22 May 2008, Melbourne, Australia.
- Smith, R. J., Raine, S. R., McCarthy, A. C. and Hancock, N. H. 2009, 'Managing spacial and temporal variability in irrigated agriculture through adaptive control', *Australian Journal of Multi-disciplinary Engineering*, 7(1), 79-90.
- Smith, R. J., Raine, S. R. and Minkovich, J. 2005, 'Irrigation application efficiency and deep drainage potential under surface irrigated cotton', *Agricultural Water Management*, 71(2), 117-130.
- SPACEPAC 2010, '*Overbank Siphons*', viewed 14 March 2010, <http://www.spacepac.com.au/Brochures/Durapoly/Cat09-10/Farm_Products_6pg_np.pdf>.
- Walker, W. R. and Skogerboe, G, V. 1987, 'Surface irrigation theory and practice', Englewood Cliffs, N. J., Prentice Hall
- Walker, W. R. 1989 'Guidelines for designing and evaluating surface irrigation systems', *FAO Irrigation Drainage Paper 45*.
- Wood, M. and Martin, M. 2000 'Improved irrigation practices for forage production: module 2. Alternative irrigation technology desktop analysis': Final Report. Department of Natural Resources and Environment, Tatura, Victoria.