

## **Processing of Polymer Matrix Composites Using Variable Frequency Microwave (VFM)**

**H S Ku, PhD Candidate, IRIS, Swinburne University of Technology (SUT);  
Faculty, University of Southern Queensland, Australia.**

**E Siores, Professor and Executive Director, Industrial Research Institute  
Swinburne (IRIS), Swinburne University of Technology (SUT), Henry Street,  
Hawthorn, VIC 3122, Australia.**

**J A R Ball, A/Prof & Head, Electrical, Electronic & Computer Engineering,  
University of Southern Queensland (USQ), West Street, Toowoomba, 4350  
Australia.**

**F Siu, PhD Candidate, IRIS, Swinburne University of Technology (SUT);  
Lecturer, Kwun Tong Campus, Hong Kong Institute of Vocational Education, 25  
Hiu Ming St., Kwun Tong, Hong Kong.**

### **ABSTRACT**

Microwave processing of polymeric matrix composite materials is a relatively new technology advancement alternative that provides new approaches for enhancing material properties as well as economic advantages through energy savings and accelerated product development. However, the most commonly used facilities for microwave processing materials are of fixed frequency microwaves (FFM), eg 915 MHz and 2.45 GHz. This paper presents a review of microwave technologies, processing methods and industrial applications, using variable frequency microwave (VFM) facilities. The technique offers rapid, uniform and selective heating over a large volume at a high energy coupling efficiency. This is accomplished using a preselected bandwidth sweeping around a central frequency employing tunable frequency sources. Successful applications of these modern facilities by the authors include the characterisation of glass or carbon fibre reinforced thermoplastic matrix composites, the characterisation of primers, eg two-part five-minute rapid araldite, and the joining of the above mentioned composite materials with, or without, primers.

### **INTRODUCTION**

Factors that hinder the use of microwaves in materials processing are declining so that prospects for the development of this technology seem to be very promising (Sutton, 1989). The two mechanisms of orientation polarisation and interfacial space charge polarisation, together with dc. conductivity, form the basis of high frequency heating (Metaxas and Meredith, 1983; Siores, 1994). Clearly, advantages in utilising microwave technologies for processing polymer matrix composite materials include better penetrating radiation, controlled electric field distribution and selective and volumetric heating. However, the most commonly used facilities for microwave processing materials and curing of adhesives are of fixed frequency, eg 915 MHz and 2.45 GHz. Variable frequency microwave (VFM) facilities present a new alternative

for microwave processing. The technique is geared towards advanced materials processing and chemical synthesis. It offers rapid, uniform and selective heating over a large volume at a high energy coupling efficiency. This is accomplished using a preselected bandwidth sweeping around a central frequency employing tunable frequency sources such as travelling wave tubes (TWTs) as the microwave power amplifier. Selective heating of complex samples and industrial scale-up are now viable. During VFM processing, a given frequency of microwaves would only be launched for less than one millisecond (Ku et al, 2000a).

Two such facilities are available at the Industrial Research Institute, Swinburne (IRIS). One, Microcure 2100 Model 250 (Figure 1) with a maximum power output of 250W generates microwave energy in the frequency range of 2 – 7 GHz and the other, VW1500 (Figure 2), operates at 6 – 18 GHz with a maximum power level of 125W. The cavity dimension of VW1500 was 250 mm x 250 mm x 300 mm; while, Microcure 2100 Model 250 had a cavity size of 300 mm x 275 mm x 375 mm.



**Figure 1: Cavity of Microcure 2100 Model 250 with Frequency Range of 2 - 7 GHz and a Maximum Power of 250 W**



**Figure 2: Cavity of VW 1500 Model with Frequency range of 6 -18 GHz and a Maximum Power of 125 W**

Variable frequency spectra have been investigated for a number of processing applications. Demeuse and Johnson (1994) demonstrated that VFM furnace can uniformly heat and post-cure isocyanate/epoxy plates over a volume of 200 cubic centimetres. Surret, et al (1994) showed that sweep frequency heating produces more uniform curing in thermosetting composite systems (carbon fibre/epoxy resin laminates). Fathi, et al (1995) investigated heating thermoset polymer matrix composite materials and showed that thermal runaway and hot spots problems associated with fixed frequency heating were overcome. Qui, et al (1995) showed how frequency switching enabled modes with high heating rates and desirable heating patterns to be selected to allow uniform heating of graphite epoxy load. Ku, et al (1997a; 1997b; 1999a; 2000a) successfully joined thermoplastic matrix composite materials. Anderson, et al (undated) cured advanced polymeric adhesives and encapsulants, and rapid processing of flip-chip (FC). Fathi, et al (undated) carried out structural bonding of glass to plastic housing. Wei, et al (1998) have looked at

variable frequency heating for bonding applications in polymer composites and electronic packaging. Bows (1999) developed variable frequency heating procedures to overcome the geometry of a roughly spherical foodstuffs dominating the heating pattern when heated in a fixed frequency applicators. Ku, et al (2000b) performed adhesive characterisation successfully.

There are a lot of factors that have to be considered before employing variable frequency microwave (VFM) irradiation for processing materials. Not all materials are suitable for microwave processing and one has to match the special characteristics of the process with the physical and chemical properties of the materials being processed. Blind applications of microwave energy in material processing will usually lead to disappointment. On the other hand, smart applications of the technology will have greater benefits than has been anticipated (NRC, 1994; Ku et al, 1999b).

Successful applications of these modern facilities by the authors include the characterisation of glass or carbon fibre reinforced thermoplastic matrix composites, eg 33% by weight glass fibre reinforced low density polyethylene [LDPE/GF (33%)], of primers eg two-part five-minute rapid araldite, and joining of the above mentioned composite materials with, or without, primers (Ku et al, 2000a; 2000c; Siu et al, 2001).

## **VARIABLE FREQUENCY MICROWAVES**

Mackay, et al (1979) first conceptualised the idea of variable frequency microwave (VFM) facility and it was not until Bible, et al (1992) designed and built the first VFM processing system using a high power travelling wave tube (TWT) amplifier capable of supplying up to 2.5 kW power over the frequency range of 4-8 GHz. The frequency range can be extended by the addition of other TWTs.

Microwave-based processing approaches can be broadly divided into either single-mode or multimode cavities. The single mode cavity approach makes use of a tunable microwave cavity specifically designed to support a single resonant mode at the frequency of the microwave source. This ensures maximum coupling of the microwave energy into the load. However, the single mode nature of the cavity limits the area of high electric fields intensity and, thus, the size, shape and positioning of the material to be processed. The multimode cavity approach makes use of a cavity that is overmoded, which means it is large enough to support a number of high-order modes, often at the same frequency. However, the power distribution at a single frequency is uneven and can result in multiple hot spots (Lauf and Bible, 1993).

The VFM uses a TWT high power, broadband amplifier to sweep a range of frequencies of approximately an octave in bandwidth. The concept behind this approach is that continuous sweeping through several cavity modes within a period of a few milliseconds results in time-averaged uniformity of heating throughout the load. The resulting relative power distribution pattern in a plane with fixed frequency (2.45 GHz) heating is not uniform. There is no mode control and hence the coupling efficiency is uncontrolled. On top of it, there is limited scaleup and high potential for

hot spots and thermal runaway. On the other hand, the resulting relative power distribution pattern in a similar plane with VFM heating is uniform. There is selective frequency control, high energy coupling efficiency, scaleable to large processing volumes and uniform heating throughout (Lambda Technology, undated).

### JOINING OF NYLON 66/GF (33%) WITH RAPID ARALDITE USING VFM

The two mirror image test pieces of Nylon 66/GF (33%) were cut from a standard tensile test piece (Figure 3) for composite materials (Ku et al, 1997a; 1997b). Lap joint was selected for the connection of the two tensile test pieces. The lapped area was made to be 20 mm x 10 mm. The lapped areas were first roughened by rubbing them against coarse, grade 80, emery paper. They were then cleaned in methanol solution and allowed to dry in air before applying primer onto them. After applying the rapid araldite (1.5 to 2.0 cc), the two pieces were pressure bound using a dielectric band (Figure 3). This fixed the relative position between the two test pieces and applied pressure onto the lap joint. The pressure on the lap joint was estimated to be 4

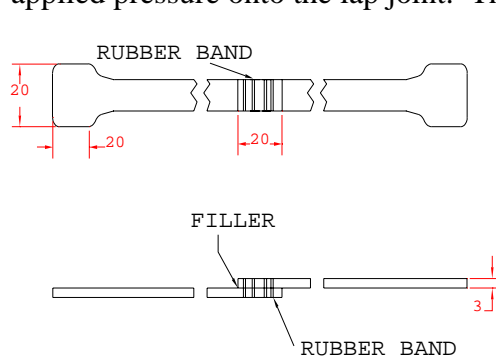

**Figure 3: Two Mirror Image Test Pieces of Nylon 66/GF (33%)**

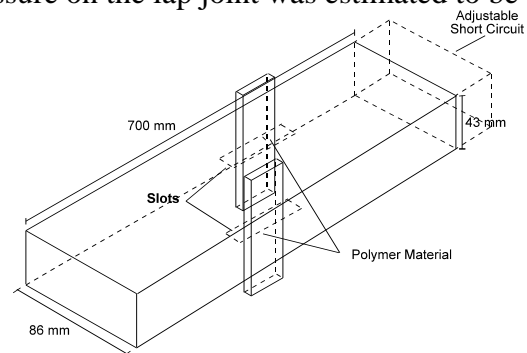

**Figure 4: Slotted Waveguide Used for Joining Nylon 66/ GF (33%) Using Rapid Araldite**

N. The Nylon 66/GF (33%) test pieces were then joined using VFMF by placing them in the cavity of the facility.

The best frequency to process rapid araldite and Nylon 66/GF (33%) using Microcure 2100 ie frequency range between 2 GHz to 8 GHz was from 6.5 GHz to 8 GHz and 6.5 GHz to 7.5 GHz (Ku et al, 2000a; 2000c). Since the material was processed with variable frequency sweep, it was necessary to find out the centre frequency for the sweep. Since the best processing range for the materials was from 6.5 GHz to 8GHz, the centre frequency sweep was 7.25 GHz and the bandwidth of sweep of 1.5 GHz was chosen (Lambda Technologies Inc., 1998; Bows, 1999). The sweep time ranged from 0.1 second to 100 seconds (Lambda Technologies Inc., 1998) and the chosen sweep time was 0.1 second. Since the material loss tangent was relatively low (Ku, et al, 1999b; 1999c; 2000d), a power level of 200 W was selected. For the sake of tensile shear tests, several sets of test pieces were joined at different duration and details are discussed later.

## JOINING OF NYLON 66/GF (33%) WITH RAPID ARALDITE USING FIXED FREQUENCY MICROWAVES (FFM)

To discuss the joining of Nylon 66/GF (33%) with adhesives using variable frequency microwaves without mentioning the joining of them utilising its fixed frequency counterpart will be incomplete. The method involved the use of a TE<sub>10</sub> mode rectangular waveguide operating in a standing wave configuration. Slots were machined in the waveguide allowing the adhesive layer on the specimens to pass through the microwave region. Nylon 66/GF (33%) specimens with the same lap area and surface treatment were located in a standard rectangular waveguide as depicted in Figure 4 (Ku et al, 1997a; Siores and Groombridge, 1997). To avoid microwave irradiation leakage, the slotted waveguide was enclosed in a modified commercial microwave oven case (Ku et al, 1997a; 1997b). One and a half to two cc of rapid araldite were smeared on both surfaces of the lapped area. A short circuit was adjusted to ensure that the maximum of the standing wave coincide with the lapped area of the specimen (Ku et al, 1997a; 1997b). The samples were exposed to 240 W and 400 W of power at different processing times. The magnetron was operating at

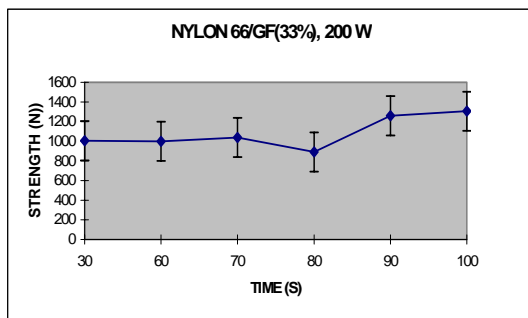

Figure 5: Bond Strength of Nylon 66/GF (33%) with Araldite Using VMF

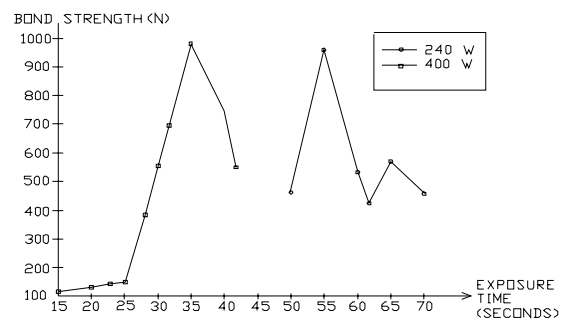

Figure 6: Bond Strength of Nylon 66/GF (33%) with Araldite Using FFM

2.45 GHz. The bonds formed were tensile shear tested and the results are outlined later.

## EXPERIMENTAL RESULTS

### Joining of Nylon 66/GF (33%) by VMF

Figure 5 illustrates the bond strength of Nylon 66/GF (33%) against different exposure time intervals. During most of the exposure period, the bond strengths of the test pieces were found to be above 1000N or shear strength of over 5 N/mm<sup>2</sup> and test pieces failed at bondline. At an exposure time of 35 seconds, the bond strength of the test piece joined by VMF was around 1005 N; at an exposure time of 55 seconds, the bond strength using VMF was 1050 N.

### Joining of Nylon 66/GF (33%) by FFM

With Nylon 66/GF (33%), the peak bond strengths obtained were at exposure times of 35 and 55 seconds with power levels of 400 W and 240 W respectively (Figure 6). They were 32% and 28% respectively higher than those obtained by curing the adhesive at room temperature conditions but the times required were only 0.06% and 0.1% of their counterparts (Ku et al, 1997a; 1997b; 1999a).

## CONCLUSION

In the joining of Nylon 66/GF (33%) with araldite as primer, it was found that at an exposure time of 35 seconds, the bond strength of the test piece joined by VFM was around 1005 N, which was 1.5% higher than that obtained from the fixed frequency facilities using a power level of 400 W. Similarly, at an exposure time of 55 seconds, the bond strength using VFM was 1050 N, which was 9 % higher than that achieved from its rival operating at 240 W. In both cases, the bond strengths obtained by VFM irradiation are higher than those achieved by FFM. In addition, the power used in VFM joining was only 200 W. It can be argued that VFM is more suitable for joining Nylon 66/GF (33%) than its fixed frequency counterpart. It is also believed that, within limits, the higher the power of the VFM facility, the higher will be the bond strength of the material.

Figure 5 shows that, within limits, the longer the time of exposure to variable frequency microwave energy, the higher will be the bondline strength of the material. At an exposure time of 100 seconds, the bond strength was 1305 N, which is 74% higher than that achieved by curing the adhesive at ambient conditions (Ku et al, 1997b). Since the tensile strength of Nylon 66/GF (33%) is 172.17 N/mm<sup>2</sup> (Ku et al, 2000b), there was plenty of room for improving its tensile shear strength without weakening the parent material due to the selective heating of VFM (Ku et al, 1997a).

Many of the above adhesive curing experiments are experimental and time-consuming. Computer simulations of variable frequency heating or curing are therefore recommended (Bows, 1999). The cost of higher power commercial VFM facilities, eg Microcure 2100 Model 2000, are currently expensive and in most industrial scale applications only the high power facilities will meet the demand of the loads. It is likely that multiple single-frequency sources, eg, magnetrons or narrow-band sources (tens of MHz) would be preferred as they are currently inexpensive and more powerful than amplified TWT devices (Bows, 1999).

The general significance of this work is that it shows to the composite material research community that VFM facilities can be applied to process polymeric composite materials and that hot spots and thermal runaway problems associated with fixed frequency heating can be overcome (Siores et al, 2000).

## REFERENCES:

Anderson, B., et al (undated), Rapid Processing and Properties Evaluation of Flip-Chip Underfills, <http://www.microcure.com/papers.htm>, undated, pp. 1 – 9.

Bible, D.W., Lauf, R.J. and Everleigh, C.A. (1992), Multi-kW Variable Frequency Microwave Furnace, Microwave Processing of Materials III, Materials Research Society, San Francisco, C.A.

Bows, J.R., Variable Frequency Microwave Heating of Food, *Journal of Microwave Power and Electromagnetic Energy*, Vol. 34, No. 4, 1999, pp.227-38.

DeMeuse, M.T. and Johnson, A.C. (1994), Variable Frequency Microwave Processing of Thermoset Polymer Matrix Composites, *Mat. Res. Soc. Symp. Proc.* Vol. 347, pp.723-8.

Fathi, Z, Garard, R.S., DeMeuse, M.T., Clemens, J., and Saltiel, C. (1995), Processing and Modelling of Select pmcs using Variable Frequency Microwave Irradiation. In: *Proceedings 209th American Chemical Society National Meeting & Exposition, Anaheim, Los Angeles. American Chemical Society.*

Ku, H S, Siores, E, Ball, J A R (1997a), Weldability and Heat Affected Zone (HAZ) Evaluation for High Energy Rate Joining of Thermoplastic Composites Using Microwave, *Proceedings of ICCM-11, Vol VI, Gold Coast, Australia, 14th-18th July*, pp. 55 - 64.

Ku, H S, Siores, E, Ball, J A R (1997b), Welding of Thermoplastic Composite Using Microwave Energy, *Proceedings of CIRP International Symposium - Advanced Design and Manufacturing in the Global Manufacturing Era, Vol 2, Hong Kong, August 21 - 22*, pp. 612 - 8.

Ku, H S, Siores, E, Ball, J A R (1999a), Microwave Facilities for Welding Thermoplastic Composites, and Preliminary Results, *Journal of Microwave Power and Electromagnetic Energy*, Vol. 34(4), December, pp. 195-205.

Ku, H S, Siores, E, Ball, J A R and Chan, P (1999b), Complex Permittivity of Low Loss Thermoplastic Composites Using a Resonant Cavity Method, *Proceedings of ICCM-12 in CD ROM, Theme: NDT & Reliability; Others, Paris, France, 5<sup>th</sup> - 9<sup>th</sup> July.*

Ku, H S, Siores, E, Ball, J A R and P K H Chan (1999c), Loss Tangent of Low Loss Thermoplastic Composites, *Science and Engineering of Composite Materials*, Vol. 8, No. 3, pp. 123-7.

Ku, H.S., MacRobert, M., Siores, E. and Ball, J.A.R. (2000a), Variable Frequency Microwave Processing of Thermoplastic Composites, *Plastics, Rubber and Composites* (final manuscript submitted).

Ku, H.S., MacRobert, M., Siores, E. and Ball, J.A.R. (2000b), Characterisation of Thermoplastic Matrix Composites (TPC) Using Variable Frequency Microwave (VFM), *Plastics, Rubber and Composites* (submitted for publication).

Ku, H, Siu, F, S, Siores, E and Ball J A R (2000c), Applications of Fixed and Variable Frequency Microwave (VFM) Facilities in Polymeric Materials Processing and Joining, *Journal of Materials Processing*, 2000, pp. (submitted for publication).

Ku, H S, Siores, E, Ball, J A R and Horsfield, B (2000d), Permittivity Measurement of Thermoplastic Composites at Elevated Temperature, *Journal of Microwave Power and Electromagnetic Energy*, pp. (final manuscript submitted for publication).

Siores, E, Ku, H S, Ball, J A R and MacRobert, M (2000) Applications of Variable Frequency Microwave (VFM) On Adhesives, *International Symposium on Adhesives: Synthesis, Characterization and Applications, Proceedings Volume, Journal of Adhesion Science and Technology*, Newark, NJ, USA, December 4-6, pp. (accepted for publication).

Lambda Technology Inc. (undated), What is Variable Frequency Microwave Processing? <http://www.microcure.com>, pp. 1 – 2.

Lambda Technologies Inc. (1998), Operator's Manual for Microcure 2100, Models 250, 700 and 2000, pp. 2.1-3, 3.1-3, 4.1-10, 4.15-24, 4.30-33.

Lauf, R.J. and Bible, D.W. (1993), 2 – 18 GHz Broadband Microwave Heating Systems, *Microwave Journal*, pp. 24 – 34.

Mackay, A., Tinga, W.R. and Everleigh, C.A. (1979), Frequency Agile Sources for Microwave Ovens, *Journal of Microwave Power*, Vol. 1, pp. 63-76.

Metaxas, A.C. and Meredith, R.J. (1983), *Industrial Microwave Heating*, Peter Peregrinus Ltd., pp. 5-6, 28-31, 43, 211, 217, 278, 284-5.

NRC (National Research Centre) (1994), *Microwave Processing of Materials*, National Advisory Board Commission on Engineering and Technical Systems, National Research Council, USA, p.7, 11-2, 100, 105.

Qui, Y., Adegbite, V. and Hawley, M (1995), Microwave Processing Using Intelligent Frequency Switching: System Setup and Characterisation Results. In: *Proceedings 30<sup>th</sup> Microwave Power Symposium*, Denver, US, 55-88. International Microwave Power Institute, Manassas, US.

Siores, E. (1994), Microwave Technology for Welding and Joining, *Materials World*, Vol. 2, No. 10, p.526.

Siores, E. and Groombridge, P. (1997), Preliminary Investigations into the Use of Microwave Energy for Fast Curing of Adhesively Bonded Joints Formed Using Engineering Plastics, *Ceramic Society Bulletin*, May, No. 8, pp. 437 –44.

Siu, F, Ku, H S, Siores, E and Ball J A R, Variable Frequency Processing of Thermoplastic Composites, *Journal of Materials Processing*, 2001, pp. (submitted for publication).

Surrett, A.D., Lauf, R.J., and Paulauskas, F.L. (1994), Microwave Processing of Thermosetting Prepreg Laminates. In: *Proceedings 29<sup>th</sup> Microwave Power Symposium*, Chicago, US, 95-98. International Microwave Power Institute, Manassas, US.



Sutton, W.H. (1989), Microwave Processing of Ceramics, Ceramic Bulletin, Vol. 68, No. 2, pp. 376-86.

Wei, J.B., Ngo, K., Tucker, D.A., Fathi, Z., Paulauskas, F.L. and Johanson, W.G. (1998), Industrial Processing via Variable Frequency Microwave Part I: Bonding Applications, Journal of Microwave Power and Electromagnetic Energy, Vol. 33, No. 1, pp. 10-7.