

# Investigation on role and function of noggings in residential timber frame construction

W. Karunasena

*Centre of Excellence in Engineered Fibre Composites, Faculty of Engineering and Surveying, University of Southern Queensland, Toowoomba, QLD 4350, Australia*

C. J. Leitch

*Cyclone Testing Station, School of Engineering, James Cook University, Townsville, Qld 4811, Australia.*

**ABSTRACT:** Currently, there is no consensus among wall frame manufacturers, engineers and builders on the role and function of wall noggings as required by AS1684. It is not clear whether they are prescribed for structural adequacy, serviceability or buildability reasons. This paper presents an investigation into the role and function of noggings and includes: (1) a literature review on wall framing, including summary findings of an industry survey to establish relevant issues for noggings; (2) review of nogging design criteria; (3) nogging alternatives; (4) structural analysis of nogging systems; (5) structural testing; and (6) key results and comparisons between tests and structural analysis. Key preliminary conclusions are that edge nogging could be used instead of flat (normal) nogging and that structurally, there may not be any need for nogging. However, these trends were not able to be conclusively confirmed from the pilot test program undertaken due to the inherent timber variability and the limited number of test replications.

## 1 INTRODUCTION

Timber remains a popular material for residential construction in Australia and many other countries. One of the first comprehensive life cycle assessments studies conducted in the US in the mid-1970s found that timber frame construction uses only one-half to one-seventh the energy needed for construction using steel, aluminium, concrete block or brick (Bowyer 2004). Another study from the mid-1990s, considered the use of re-cycled steel wall studs and found that the manufacturing energy differences between timber and steel-framed walls narrowed but timber still retained a significant advantage (Bowyer 2004). With 50% recycled-steel content in the steel-framed wall, it was found that these walls were some four times more energy intensive in comparison to timber-framed walls, and, correspondingly, at least that much more environmentally damaging, despite the recycled steel content in the steel walls. This indicates that environmentally, timber-framed walls are preferred over steel-framed walls.

This investigation is concerned with nogging members in residential timber frame-walls. The Australian Standard AS1684.1 (2002) defines a nogging (which in some countries is referred to as a 'dwang' or a 'blocking') as a horizontal member fitted between studs in a wall frame, which restrains the studs against buckling in the plane of the wall. Noggings may also be used for attachment of cladding or lining or as part of bracing system.

There is often confusion within the residential timber construction industry about the role and function of wall noggings prescribed in AS1684; are wall noggings prescribed for structural adequacy, serviceability or buildability reasons? Some information about the US practice on the use of noggings was found in the web-based forum Eng-tips (2006). In summary, the forum participants stated that noggings provide a point for shear transfer from lining, stability for timber studs, and nailing surfaces, and also serves as a fire stop. One participant said that the external sheathing and internal wall covering typically provide adequate stud support and for walls 10 ft (3.05 m) and greater, noggings are required at 4 ft (1.22 m) intervals to prevent twisting of the studs. Collins (1974) published an article questioning the requirement of noggings in light timber frame wall construction. He concluded that the usual practice in New Zealand of using two or three rows of noggings in all domestic light frame timber construction could not be supported on technical grounds and wastes both material and labour. He further stated that, in certain circumstances, one mid-height row of noggings was necessary. Overall, there is very little information in the literature on the role and function of noggings in residential timber frame construction.

To date, there has been no systematic study to address the issue of whether wall noggings can be omitted altogether or alternatively whether they can be replaced by some other type of restraint.

The main objective of this study was to investigate the role and function of noggings as required by AS1684, with the intention of maximizing the efficiency and cost competitiveness of timber framed domestic construction. Our investigation consisted of an industry survey on issues related to noggings, review of current nogging design criteria, proposing nogging alternatives (to accommodate concerns of the industry), structural analysis and testing of timber frames with different nogging systems.

Initially, an industry survey was performed by interviewing key personnel from the timber framing industry to gain an insight into their perception of the role and function of noggings in residential timber framed construction. Industry survey participants suggested that: noggings are useful to keep studs together and to straighten studs, so noggings should be retained. However, they acknowledged that the use of noggings according to current practice as in AS1684 creates problems when providing services such as electrical wiring and plumbing. More information on this survey can be found in Beckman (2006).

## 2 CURRENT NOGGING DESIGN CRITERIA

The AS1684.1(2002) definition of noggings suggests that their effect is to resist stud buckling in the plane of the wall frame and that they are only deemed to act against bracing if designed in the bracing system. Therefore, it may be possible that typical noggings prescribed in AS1684 are not counted in the strength calculations for wall bracing. So, from a design perspective, the main effect of noggings is to reduce the stud effective length, thereby, increasing their buckling load capacity in the plane of the frame.

The prescription for noggings in Cyclonic and Non-Cyclonic areas are the same. However, in the simplified Non-Cyclonic area there is a slight difference. AS1684.2 (2006) and AS1684.3 (2006) clause 6.2.1.5 stipulates the following for noggings (see Figure 1):

- Wall studs shall have continuous rows of noggings at 1350 mm maximum centres.
- Noggings not required to be stress graded.
- Nogging thickness shall be a minimum of 25 mm and shall be suitable for the proper fixing of cladding and linings.
- Noggings shall be installed either centrally in the depth of the studs or flush with one face of the stud in order to provide fixing support to cladding or linings. Stagger in the row of noggings shall be not greater than twice the nogging breadth.

AS1684.4 (2006) clause 6.2.1.5 is exactly the same as the previous one except for the following stipulation on the minimum nogging size:

- Nogging thickness shall be suitable for the proper fixing of cladding and linings.

This indicates that when simplifying the 'Non-Cyclonic Areas section' of AS1684, it has been assumed that noggings may be as small as desired and, therefore, are not designed to resist any significant lateral loads.

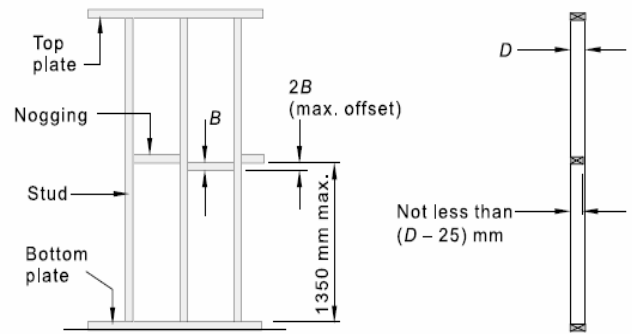

Figure 1. Nogging specifications in AS1684  
( Source: AS1684.3 (2006) )

## 3 NOGGING ALTERNATIVES

When determining alternative nogging or bracing systems we must look from point of view of builders, engineers, manufactures and home owner. As cost of materials and construction time (which is directly related to labour costs) are the major factors which govern the design of residential housing, any design features which can minimise either of these factors are of great importance. Other forms of nogging that may be suitable are given in this section.

### 3.1 Timber noggings 'on edge'

Timber noggings are generally the same depth as the studs and installed 'on the flat' (also referred to as normal noggings in this paper), so they are the full depth of the wall as shown in Figure 2(a).

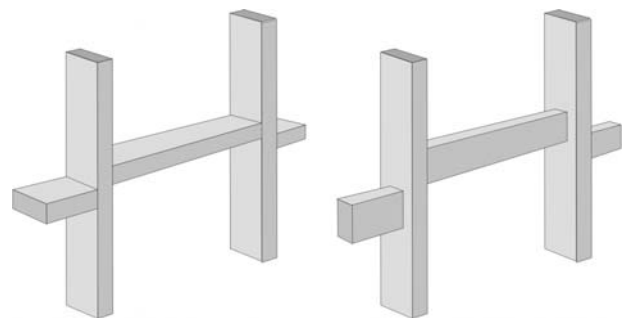

Figure 2(a) .  
Nogging 'on flat'.

Figure 2(b) .  
Nogging 'on edge'.

Although not in accordance with AS1684, it would be an advantage to place noggings 'on edge' as shown in Figure 2(b). This requires less precision when fixing the nogging and also allows for services (electrical & plumbing) to be installed without the need to drill holes through the nogging.

### 3.2 Flat metal strap

Flat Metal strap (typically 30 x 0.8 mm) shown in Figure 3 has previously been used by some builders in Australia.

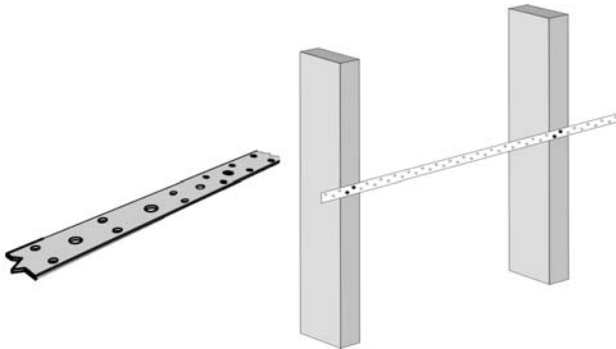

Figure 3. Flat metal strap

### 3.3 Other nogging types

Other nogging types that have been sparingly used in the past are metal angles and belt rails, but they are not considered here.

## 4 STRUCTURAL ANALYSIS

A detailed structural analysis to show the effect of various nogging arrangements on the structural behaviour of wall frames was conducted using Strand7 finite element (FE) analysis software package. Computer modelling of timber framed walls is an effective way of deducing the structural effects that noggings have in typical construction situations. The computer modelling conducted in Strand7 along with laboratory testing helps to provide an insight into dependable modelling procedures for timber wall frame construction.

Due to space limitations, analysis details are not presented here but they can be found in Beckman (2006). Only some key results are presented Section 6 to compare with experimental results. In summary, the effects of different noggings systems on racking stiffness, lateral stiffness, compression stiffness, compression buckling loads, and lateral patch load response in typical 2, 3 and 4 bay wall frames were investigated in the structural analysis using Strand7. Different timber grades and combined actions were considered in the analysis. From the analysis it was

clear that noggings have no effect on the racking and compression stiffness of the wall frame. Also it was found that the noggings have a very small effect on the lateral stiffness, compression buckling loads and the lateral patch load response. The maximum effect observed was a 5% deviation (relative to 'flat noggings') corresponding to the 'no noggings' application in the patch load response.

## 5 STRUCTURAL TESTING

Due to high cost involved in testing, only a pilot testing program was carried out to verify key findings of the FE analysis. The FE analysis has shown that the nogging system has no influence on the racking stiffness of the wall frame. Also it was revealed that different nogging systems have insignificant effect on the structural response of wall frames subjected to combined actions. The test program considered only compression and lateral loads acting independently on the wall frames as these load cases showed some nogging effect in the FE analysis.

### 5.1 Compression tests

The compression tests were carried out by erecting wall frames and installing them into a specially prepared loading rig which was used to apply a compression load to the frames via a set of four hydraulic jacks. The testing rig had a series of displacement gauges called LVRTs (Linear Variable Resistance Transducers) to measure displacements corresponding to different loads. A schematic diagram of the compression testing rig and LVRT locations are shown in Figure 4.

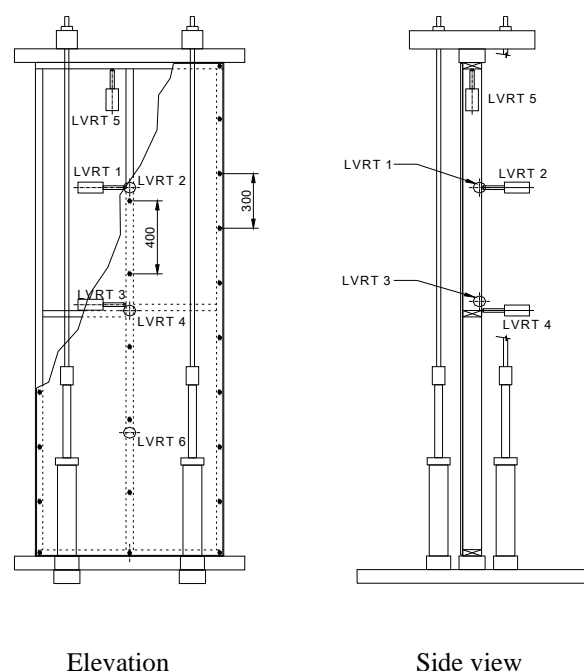

Figure 4: Schematic diagram of the compression testing rig

The details of the compression test program are given in Table 1.

Table 1. Compression test program

Stud Size (mm)	Trial No.	Nogging Details		
		Nogging Fitted?	Size & Material	Orientation
70 x 35	1	NO	NONE	NONE
	2, 5	NO	NONE	NONE
	3, 6	YES	70 x 35 Timber	EDGE
	4, 7	YES	70 x 35 Timber	FLAT
90 x 35	8	YES	90 x 35 Timber	NONE
	9	YES	90 x 35 Timber	EDGE
	10	YES	90 x 35 Timber	FLAT
	11	YES	30 x 1 Metal Strap	EDGE
	12	YES	90 x 35 Timber	FLAT

Notes:

- 1 All trials except Trial 1 had wall lining (10 mm thick Gyrock plasterboard) fitted.
- 2 Timber grade: Trials 1 to 7 and 12 – MGP10 (studs and noggings), Trials 8 to 10 – MGP12 (stud and noggings), Trial 11 – MGP12 (studs).
- 3 Trials 5, 6, 7 replicates of Trials 2, 3, 4, respectively.

### 5.2 Lateral load tests (bending tests)

The original plan of four uniformly distributed lateral load tests was modified to four lateral patch load tests to investigate the load-deformation behaviour of wall frames. For this test program, a lateral patch load acting over a small area (150 mm side square) of the plasterboard lining was applied. These lateral loads represent a concentrated load, such as that applied by a hand or a chair-back, or as a distributed load caused by leaning against a wall. The schematic plan of a bending test wall frame is shown in Figure 5.

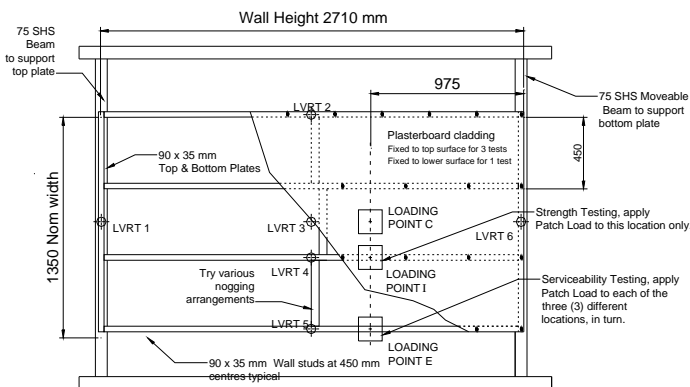

Figure 5. Schematic plan of bending test wall frame and LVRT arrangement

The three lateral load locations and the positions of the LVRTs set up to measure the corresponding vertical displacements at different points are shown in Figure 5. All four test frames consisted of:

- 3 bays (i.e. 4 studs) with wall height 2.71 m and width 1.35 m.
- stud size 90x35 mm, wall plates 90x35 mm, and noggings 90x35 mm (if fitted).
- studs, wall plates, and noggings from MGP12 grade timber.

The details of the bending test program are given in Table 2.

Table 2: Bending test program

Stud Size (mm)	Trial No.	Nogging Details		
		Nogging Fitted?	Size & Material	Orientation
90 x 35	13	YES	90 x 35 Timber	FLAT
	14	YES	90 x 35 Timber	EDGE
	15	NO	NONE	N/A
	16	YES	90 x35 Timber	EDGE

Notes:

- 1 All linings are fitted to the top face of wall frame, except in Trial 16 in which lining is fitted to the bottom face of wall frame.
- 2 All trials had a 10 mm thick Gyrock plasterboard wall lining fitted

## 6 RESULTS AND DISCUSSION

### 6.1 Compression loading results

Compression test results for all LVRT locations for have been presented as deflections versus load plots in Crawford (2006). Only a few key results are presented in this paper. Figure 6 shows the comparison of test results for vertical deflection at LVRT5 for different nogging arrangements for timber grade MGP12 and studs size 90x35 (Trial 8, 9 and 10). It is seen from Figure 6 that the vertical displacement response of edge noggings and flat (normal) noggings systems are very similar and that of 'no noggings' case is not far away from the edge and flat nogging cases.

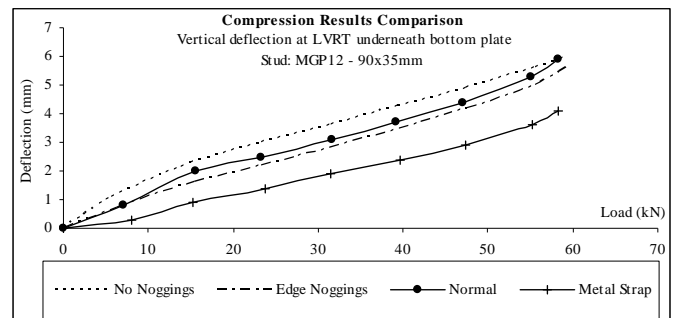

Figure 6. Comparison of compression test results of vertical deflection at LVRT5 underneath Top Plate for Trials 8, 9 and 10.

FE analysis results for the wall frame, normalised by dividing the deflection or lowest buckling load by that of the flat (normal) nogging type, are shown in Table 3. These results are for different type of nog-

gings with timber grade MGP12 and stud size 90x35 mm. These modelling results show that having different nogging options or having no noggings has an insignificant effect on the compression stiffness of the wall frame or on the buckling load.

Table 3: FE analysis results of normalised deflection and lowest compression buckling load for different nogging systems.

Nogging type	LVRT 2	LVRT 4	LVRT 5	LVRT 6	Buckling load
Flat	1.00	1.00	1.00	1.00	1.00
Edge	1.00	1.00	1.00	1.00	1.00
None	1.00	1.00	1.00	1.00	1.00
Metal strap	1.00	1.00	1.00	1.00	1.00

Notes: All results have been normalised with respect to the 'flat nogging' case results.  
Buckling load refers to the normalised value of the lowest compression buckling load.

Figure 7 shows a comparison of FE analysis with test results for the deflections of the frame at LVRT5 (which was underneath the top plate).

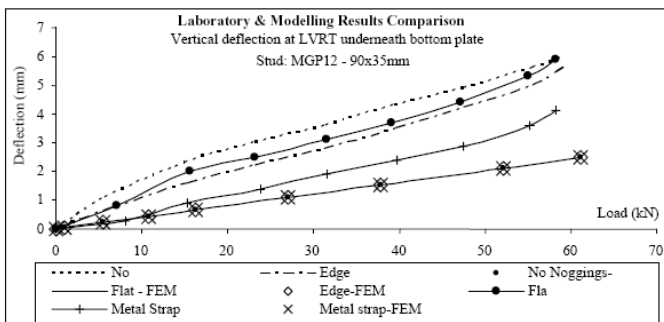

Figure 7. Comparison between FE analysis and test results for vertical deflection at LVRT5 in top plate (MGP12 Timber grade)

Figure 7 shows that the trend lines are similar for FE analysis and structural test deflections results. However, structural test deflections are higher than those from the FE analysis. This may be due to the FE analysis assumption of a rigid link connection between the lining and studs. In the FE modelling, the wall frame and lining form a monolithic structure which allows the load to be transmitted directly from wall frame to lining through the rigid link. However, in the structural tests, screws are used to connect the lining to the wall frame. When the wall panel is loaded in the test, only part of the load (relative to that of numerical modelling) is transferred to the lining, due to the rotation of screws and no proper bonding between screws and lining. Thus the studs in test wall panels may be transmitting higher loads than the studs in the numerical wall panels, resulting in higher vertical deflections.

## 6.2 Lateral loading results

Figure 8 shows a comparison of lateral load test displacements for different type of nogging arrangements when the load is applied at point C (Refer to Fig. 5 for location of C).

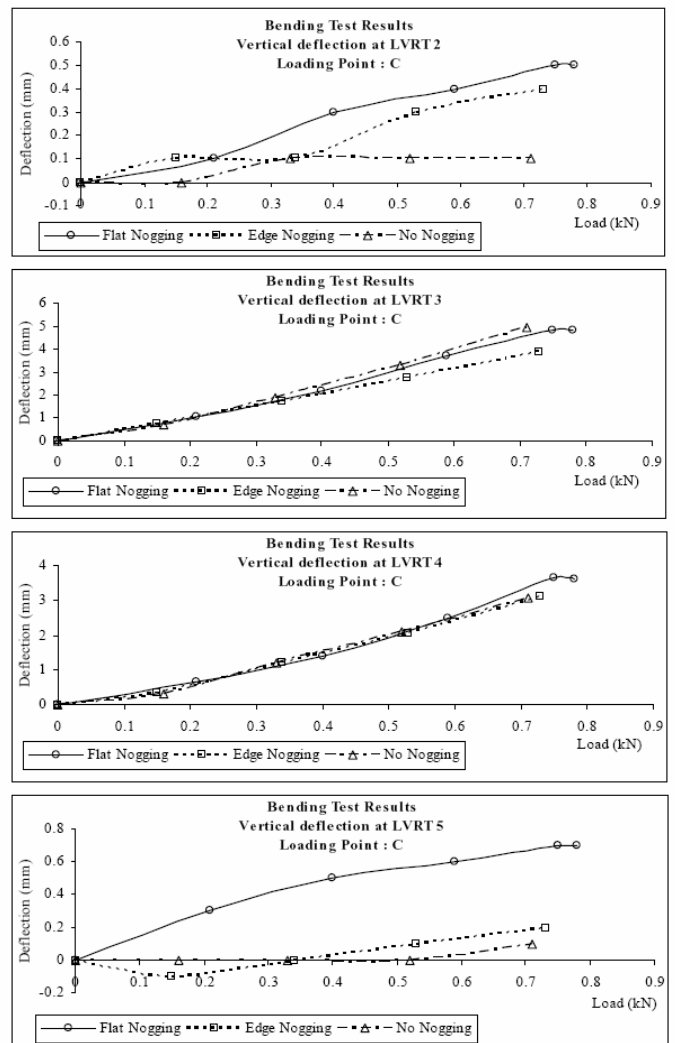

Figure 8. Comparison of lateral load test results for displacements for different type of nogging arrangements when load is applied at point C (Refer to Fig. 5 for location of C).

Similar comparisons for load applied at points E and I were made but are not shown here due to space limitations. It was observed that nearly the same displacements were recorded by the LVRTs adjacent to the loaded area for different type of noggings. As the distance of the LVRTs from the loaded area increased, significantly different displacements could be seen for different noggings types. However, the displacements corresponding to edge and no noggings were in reasonably good agreement. For flat noggings, higher deflections were recorded at LVRT5 for loading cases C and I, and at LVRT4 for loading case E. The main reason for these high deflections would be the presence of knots immediately below the loading point E and I, which lowered the local stiffness of timber, and subsequently induced higher deflections.

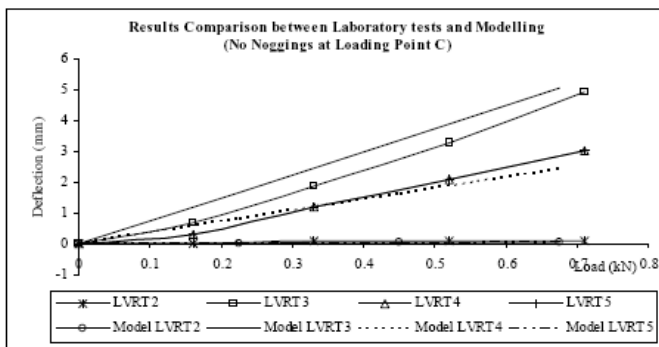
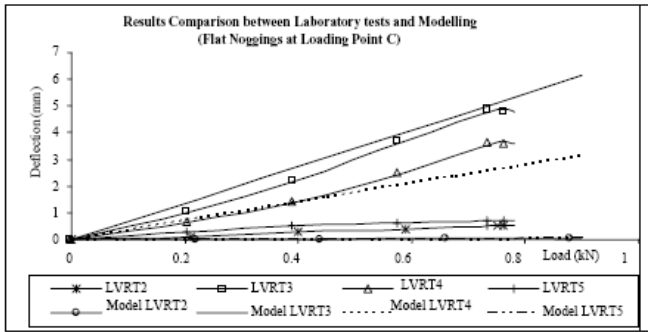
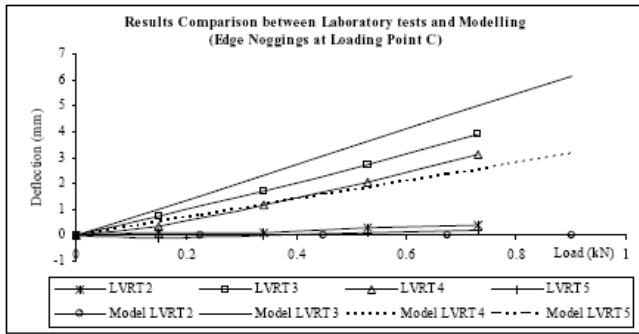

Figure 9. Comparison between FE analysis and test results for displacements when lateral load is at point C.

Comparison of the displacement results obtained from FE analysis and structural tests when lateral load is at point C, for different types of noggling arrangements, is presented in Figure 9. It is seen that modelling results agree well with test results except for LVRT3 deflections where model results are higher than test results. The errors tend to be smaller at higher loads, however, to prevent the risk of punching through the plasterboard, the wall frames were not loaded to high loads.

### 6.3 General discussion

The structural analysis using Strand7 showed that there is negligible difference between flat and edge noggings, and the case of 'No Noggings' is only slightly different to the case of flat (or edge) noggings. Given the fact that only few samples were tested (due to cost constraints), and due to variability of material properties due to knots etc., test results showed some variation from the structural analysis

findings. However, test results showed trends of flat and edge noggings behaving similarly.

## 7 CONCLUSIONS

It appears that the structural response of wall frames with flat and edge noggings have negligible difference when panels are loaded in compression, bending or combined bending and compression. For the 'no noggings' case there is a discernible difference, but this is small. Industry survey responses suggest that noggings are useful to keep studs together and to straighten studs, so noggings should be retained. However, provided edge noggings can do the straightening and keeping studs together, then based on limited evidence so far, it appears likely that edge noggings could be used rather than flat noggings. If this approach can be adopted, it will allow a useful pragmatic on-site construction practice of using edge noggings making it easier to install vertical piping, wiring, etc. down the wall cavity for services. A possible downside in this approach is that for the case of walls with lining on both sides, there is no support at noggings for lining on one side. This may not be an issue, as it was found that 'no noggings' case has only a slightly different structural response to flat or edge noggings cases.

## ACKNOWLEDGEMENT

The authors gratefully acknowledge permission from the FWPA (Forest and Wood Products Australia) to be able to report on the research study that was performed for them, using a contract research grant through Timber Queensland. FWPA is financially supported by the timber industry and the Australian Government. The authors also kindly acknowledge the research assistance provided by Ms Ching Ting, Mr. Darren Beckman, Mr. Daniel Crawford, Mr. Peter Kim and Mr. Lex Sommerville during various stages of this project.

## REFERENCES

- AS1684.1. 2002. Residential timber-framed construction – Part 1: Design Criteria. Standards Australia.
- AS1684.2. 2006. Residential timber-framed construction – Part 2: Non-cyclonic areas. Standards Australia.
- AS1684.3. 2006. Residential timber-framed construction – Part 3: Cyclonic areas. Standards Australia.
- AS1684.4. 2006. Residential timber-framed construction – Part 4: Simplified Non-cyclonic areas. Standards Australia.
- Beckman, D. 2006. The role and function of noggings in AS1684 – Part B. Undergraduate Thesis, School of Engineering, James Cook University, Townsville, Australia.
- Bowyer, J.L. 2004. Environmental benefits of wood as building materials. *Encyclopedia of Forest Sciences: 1863 -1869.*

- Collins, M.J. 1974. Are dwangs necessary in light timber frame wall construction? *New Zealand Building Inspector*, 5(3), 3-14.
- Crawford, D. 2006. The role and function of noggings in AS1684 – Part B. Undergraduate Thesis, School of Engineering, James Cook Univeristy, Townsville, Australia.
- Eng-tips. 2006. <http://eng-tips.com> Thread 'Are noggings necessary?' under the section 'Wood Design and Engineering' (March 2006).