

# Use of geopolymer concrete in column applications

Weena Lokuge<sup>1</sup>, Jay Sanjayan<sup>2</sup> and Sujeeva Setunge<sup>3</sup>

<sup>1</sup>Lecturer, Centre of Excellence in Engineered Fibre Composites (CEEFC),  
School of Civil Engineering and Surveying, University of Southern Queensland (USQ),  
Toowoomba, Queensland 4350, Australia

<sup>2</sup>Professor, Director, Centre for Sustainable Infrastructure,  
Faculty of Science Engineering & Technology, Swinburne University of Technology,  
Hawthorn, VIC 3122, Australia

<sup>3</sup>Professor, Deputy Head of School, School of Civil, Environmental and Chemical Engineering  
RMIT University, Melbourne, VIC 3001, Australia

**Abstract:** Geopolymer Concrete has been extensively studied in the past and recognised as a greener substitute for Ordinary Portland Cement (OPC) concrete. Geopolymer concrete is proven to have good engineering properties with a reduced carbon footprint. Geopolymers not only reduce the greenhouse gas emission but also use a large amount of industrial wastes such as fly ash and slag. This environmentally friendly material is being embraced by the construction industry after its use in the Global Change Institute at University of Queensland. However, research into the use of geopolymer concrete in structural applications is very limited.

This research paper aims at investigating the applicability of a constitutive relationship that authors developed for OPC concrete in predicting the constitutive relationship of geopolymer concrete. This model has the capacity to predict the lateral dilation of concrete which in turn will be used to establish the confinement provided by the lateral reinforcement in column applications. Load deformation behaviour of twelve geopolymer concrete slender columns reported in the literature is used to validate the proposed model. Since geopolymer concrete exhibits higher brittleness than OPC concrete, careful consideration should be given in the structural design of geopolymer concrete. Predicted behavior for slender geopolymer concrete columns using the proposed stress-strain relationship for confined geopolymer concrete is in good agreement with the experimental results. The outcomes of this paper will be useful in the structural analysis of geopolymer concrete columns.

**Keywords:** geopolymer concrete, stress-strain relationship, confinement, slender column.

## 1. Introduction

Emission of greenhouse gases such as carbon dioxide and nitrous oxide is a major contributing factor for global warming while the production of cement contributes about 5-7% of CO<sub>2</sub> emissions globally. Although the production of one ton of Ordinary Portland Cement (OPC) releases approximately one ton of CO<sub>2</sub> into the atmosphere [1, 2], it is widely used as a construction material around the world. As a result of few decades of research activities, geopolymer concrete (GPC) has become a potential candidate to replace the OPC concrete. It is reported that mechanical properties of GPC depend mainly on the source material, mix design and curing method [3]. However Reed et al. [4] proposed that fly ash based GPC is suitable for in-situ applications. The changes in the mortar with OPC and geopolymer are compatible with the changes in the OPC and GPC [5]. Some mechanical properties of GPC (tensile strength) are higher than those of OPC concrete [3, 5, 6], while some properties such as elastic modulus [5, 6] and flexural strength [6] are comparatively lower. Although design guidelines for geopolymer concrete are not very well documented, equations for some properties such as tensile strength, flexural strength and modulus of elasticity can be found in the literature [3, 7]. Commercial use of geopolymer concrete has taken place in the recent past for small scale applications. However the use of geopolymer concrete by Wagners, Australia in the Global Change Institute at University of Queensland and in the Wellcamp airport in Toowoomba are reported as its first structural application on large scale construction projects.

Geopolymer concrete has highly desirable structural engineering properties, which can lead to significant environmental and economical benefits. Its use is, however, limited by concerns regarding its increased brittleness compared with OPC concrete [5] and a lack of understanding of the behaviour under complex multi-axial loading conditions. The ductility of geopolymer concrete has not been investigated by many researchers in the past. The traditional method of improving ductility of columns is by using lateral confinement with steel reinforcement. However, effective methods of lateral confinement have not been reported for geopolymer concrete. The above concerns have led to very few research projects around the world [8], [9, 10]. In these studies the experimental/ analytical studies covered the behaviour of small-scale

square columns with a limited configuration of steel reinforcements, tested under laboratory conditions. In most studies, the confining pressure is assumed to be that corresponding to the yield stress of the confining steel. However the confining pressure exerted by the lateral steel is corresponding to the lateral dilation of concrete in that instance. Currently, with very limited research on the structural performance of geopolymer concrete, there is no agreement among researchers about the amount of lateral steel required in geopolymer concrete columns to provide a required level of ductility.

Based on experimental results, various stress-strain models for unconfined/confined normal or high strength concrete have been proposed in the literature [11-16]. These models can be divided into three broad categories. One group of researchers used a form of equation proposed by Sargin et al. [15]. The second group of researchers proposed a second order parabola for the ascending branch and a straight line for the descending branch and their studies were based on equations proposed by Kent and Park [14]. The third group developed stress strain relationships based on equations suggested by Popovics [16]. There are many developments to all the three preliminary equations. In these models, selected parameters were included in the stress-strain curves and then they were calibrated using the test results. There are very limited knowledge about the stress-strain relationship for unconfined/confined geopolymer concrete although it is the basis of any structural application of this new green construction material.

## 2. Existing stress-strain models for geopolymer concrete

There are two categories of constitutive models that have been discussed in the literature, one for geopolymer concrete [9, 17] and the other for geopolymer paste [18]. Haider et al. [18] developed a stress-strain model for geopolymer paste based on the experimental results with active confinement. The model proposed by the Concrete Institute of Australia is a modified version of Popovics [16] which gives a single curve for both the ascending and descending branches of the stress-strain curve for unconfined geopolymer concrete. Sarker [9] also proposed a modified version of Popovics [16] and applied this model for confined geopolymer concrete in column applications. Ganesan et al [17] used another version of Mander et al. [19] which was originally proposed by Popovics [16]. Ganesan et al [17] used the stress-strain relationship for geopolymer concrete to predict the behaviour of geopolymer concrete short columns confined by spiral reinforcement. These constitutive models are capable of predicting only the axial stress versus axial strain relationships. However, the confinement provided by lateral steel reinforcement depends on the lateral dilation of concrete. Therefore it is a timely concern to develop or investigate a complete deformational behaviour including both axial and lateral strains of laterally confined geopolymer concrete with axial compression. With the increased popularity in geopolymer concrete due to environmental and economic benefits, the greener material will be used in high-load-carrying structural members all over the world in the near future. Therefore a thorough knowledge of the material behaviour of the constituents (such as geopolymer concrete and steel) subjected to monotonically increasing loading is of great importance.

## 3. Methodology

Proposed stress-strain models for confined geopolymer concrete, steel and the procedure used in obtaining the load deformation curves are described in the following sub sections.

### 3.1 Proposed stress strain model for confined geopolymer concrete

The model proposed in this paper was originally developed by the authors for normal and high strength concrete. It is described in detail in Lokuge et al. [20]. Only one material parameter in the original model was changed to suit geopolymer concrete. Two different exponential curves form the complete stress-strain relationships for confined geopolymer concrete. The terms described in this model are illustrated in Figure 1.

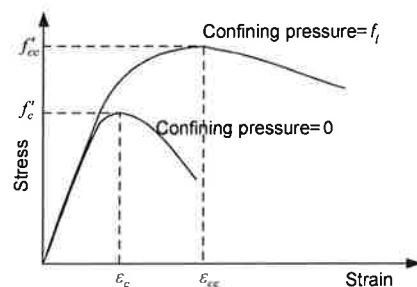

Figure 1. Typical stress-strain relationship for confined and un-confined concrete.

### 3.1.1 Relationship between axial strain and lateral strain

Relationship between axial strain  $\varepsilon_1$  and lateral strain  $\varepsilon_2$  is described below:

$$\frac{\varepsilon_2}{\varepsilon'_{cc}} = \begin{cases} \nu_i^a \left( \frac{\varepsilon_1}{\varepsilon_{cc}} \right) & \text{if } \varepsilon_1 \leq \varepsilon' \\ \left( \frac{\varepsilon_1}{\varepsilon_{cc}} \right)^a & \text{if } \varepsilon_1 > \varepsilon' \end{cases} \quad (1)$$

$\varepsilon_{cc}$  and  $\varepsilon'_{cc}$  are axial strain and lateral strain corresponding to peak axial stress.  $a$  is a material parameter which depends on the characteristic compressive strength of concrete ( $f_c$ ) and can be approximated by:

$$\mathbf{a} = 0.0177f_c + 1.2818 \quad (2)$$

$\varepsilon'$  can be obtained by equating the right hand side of Equation 1.  $\nu_i^a$ , the initial Poisson's ratio is defined as follows:

$$\nu_i^a = 8 \times 10^{-6} (f_c)^2 + 0.0002f_c + 0.138 \quad (3)$$

Equation 1 completely defines the relationship between axial strain and lateral strain if axial strain ( $\varepsilon_{cc}$ ) and lateral strain ( $\varepsilon'_{cc}$ ) corresponding to peak axial stress are known. Axial strain corresponding to peak axial stress  $\varepsilon_{cc}$  can be expressed as follows.

$$\frac{\varepsilon_{cc}}{\varepsilon_{co}} = 1 + (17 - 0.06f_c) \left( \frac{f_l}{f_c} \right) \quad (4)$$

$f_l$  is the confining pressure and  $\varepsilon_{co}$  is the axial strain corresponding to the peak uniaxial compressive strength. Peak axial stress for confined concrete  $f_{cc}$  is defined as:

$$\frac{f_{cc}}{f_c} = \left( \frac{f_l}{f_t} + 1 \right)^k \quad (5)$$

where  $k$  is a constant given by:

$$k = 1.25 \left( 1 + 0.062 \frac{f_l}{f_c} \right) (f_c)^{-0.21} \quad (6)$$

$f_t$  is the tensile strength. Tensile strength of geopolymer concrete is given by:

$$f_t = 0.9 \times 0.32 (f_c)^{0.67} \quad (7)$$

Equations 1-7 can predict the lateral strain for a given axial strain if the unconfined concrete strength and lateral strain corresponding to peak axial stress are known.

### 3.1.2 Lateral strain at peak axial stress

Similar to the observations for normal and high strength concrete [20] and for geopolymer paste [18] it is assumed that geopolymer concrete samples will return to the original volume when the axial strain is corresponding to the peak axial stress. Therefore at peak stress:

$$\bar{\varepsilon}_v = \frac{\varepsilon_1 + 2\varepsilon_2}{\varepsilon_{v,\max}} = 0 \quad (8)$$

$$\varepsilon_{cc} = 2\varepsilon'_{cc} \quad (9)$$

By introducing Poisson's ratio, Equation 9 can be written as:

$$\nu_f^a = 0.5 \quad (10)$$

where  $\nu_f^a$  is the secant value of Poisson's ratio at peak stress.

### 3.1.3 Relationship between axial stress, axial strain and lateral strain

Based on shear stress factors and shear strain factors, axial stress ( $\sigma_1$ ), axial strain ( $\varepsilon_1$ ) and lateral strain ( $\varepsilon_2$ ) constitutive behaviour of geopolymer concrete can be expressed as:

$$\sigma_1 = \begin{cases} 2\tau_{mp} \left( 1 - e^{-c \left( \frac{\varepsilon_1 + \varepsilon_2}{2\gamma_{mp}} \right)} \right) + f_l & \text{before peak} \\ 2\tau_{mp} \left( 1 - e^{d \left( \frac{\varepsilon_1 + \varepsilon_2}{2\gamma_{mp}} \right)^2} - d \right) + f_l & \text{after peak} \end{cases} \quad (11)$$

$c$  and  $d$  are material parameters defined as follows:

$$\begin{aligned} c &= -0.0427f_c + 3.15 \quad \text{and} \\ d &= -0.0003f_c - 0.0057 \end{aligned} \quad (12)$$

$c$  is the only material parameter that was modified to suit geopolymer concrete better.

$\tau_{mp}$  is the maximum shear stress at peak and  $\gamma_{mp}$  is the maximum shear strain at peak. They are defined as:

$$\tau_{mp} = \frac{f_{cc} - f_l}{2} \quad \text{and} \quad \gamma_{mp} = \frac{\varepsilon_{cc} + \varepsilon'_{cc}}{2} \quad (13)$$

Therefore complete deformational behaviour of concrete can now be generated.

### 3.2 Stress-strain model for steel

A simple idealised elasto-plastic stress-strain model was used in this investigation.

$$f_s = \begin{cases} E_{st}\varepsilon_s & \text{if } 0 \leq \varepsilon_s \leq \varepsilon_y \\ f_{sy} & \text{if } \varepsilon_s > \varepsilon_y \end{cases} \quad (14)$$

Where  $f_s$  and  $\varepsilon_s$  are steel stress and strain,  $E_{st}$  is the modulus of elasticity and  $f_{sy}$  and  $\varepsilon_y$  are the yield strength and corresponding strain of steel.

### 3.3 Load-deformation relationships

The analysis was performed by assuming plane sections remain plane after bending, perfect bond between the longitudinal steel and the concrete and only tension steel resists the tensile forces. The stress-strain relationships for concrete and steel are assumed to be as described in the previous section.

A standard pin-ended column is used in analysing the slender columns used in the experimental results reported in the literature. The procedure used in obtaining the mid height deflection is the one suggested by Rangan [21]. The deflected shape,  $v(x)$  is assumed to be represented by a sine wave as follow:

$$v(x) = \delta \sin\left(\frac{x\pi}{L_e}\right) \quad (15)$$

$L_e$  is the effective length of the column. At mid height, when  $x = L_e/2$ , the relationship between the curvature and the deflection can be obtained by:

$$\varphi\left(\frac{L_e}{2}\right) = \frac{\pi^2}{L_e^2} \delta \quad (16)$$

The section is divided into a number of strips. For an assumed strain distribution (using curvature,  $\varphi$  and strain at extreme compression side,  $\varepsilon_t$ ), stresses in core, cover and reinforcement are calculated using the corresponding stress-strain relationships. Mid height deflection calculated using Equation 14 can be used to obtain the calculated eccentricity. For a given curvature,  $\varphi$  and eccentricity,  $e^*$ , strain at extreme compression side,  $\varepsilon_t$  is iterated until the calculated eccentricity is equal to the actual eccentricity within a given tolerance level. The procedure used in getting the load-deflection curve is shown in Figure 2.

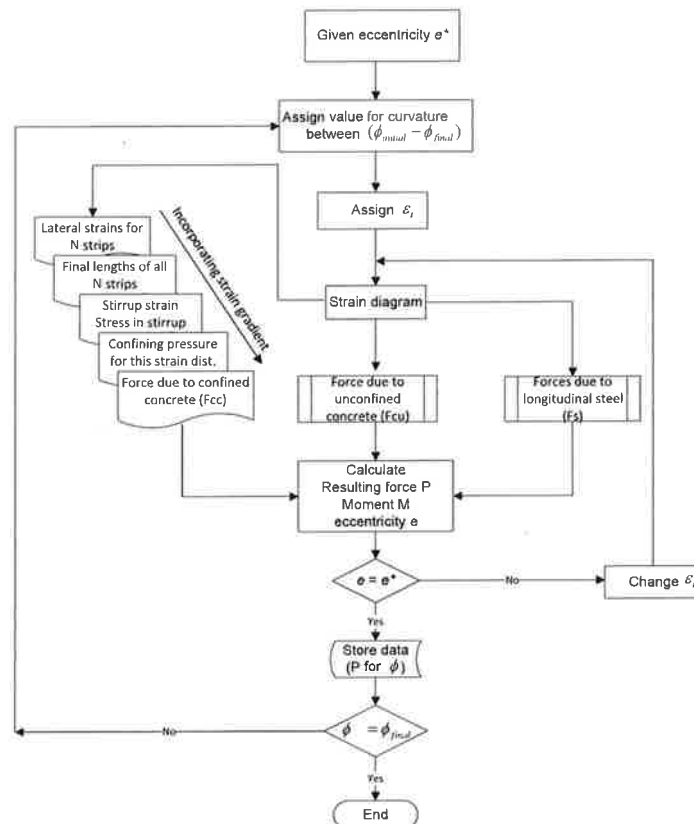

Figure 2. Flow chart used to draw load-deflection curves

#### 4. Experimental results used to compare model predictions

Twelve reinforced geopolymer concrete slender columns tested by Sumajouw et al. [8] are selected in this research to compare with model predictions. These columns were eccentrically loaded and two test series were utilized. Compressive strength of geopolymer concrete, reinforcement configuration and level of eccentricity were the test variables in their experimental program. Compressive strengths were in the range of 42-66 MPa and three level of eccentricities 15, 35 and 50 mm were used. Longitudinal reinforcement used in these columns are of type N12 deformed bars with cross sectional area of 110 mm<sup>2</sup> and yield strength of 519 MPa from tensile strength tests. Two different reinforcement configurations were used with 4N12 and 8N12. Lateral reinforcement used were 6 mm diameter hard drawn wires (W6) with 100 mm spacing for all the columns. Details of column specimens are shown in Figure 3 and Table 1. Length of all the columns was 1500 mm and the effective length was found to be 1684 mm.

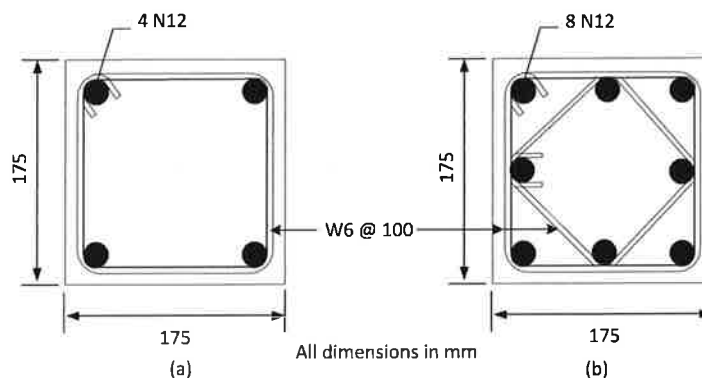

Figure 3. Details of columns [8]

**Table 1. Specimen details.**

Column	$f_c$ (MPa)	Tie reinforcement	Eccentricity (mm)
GCI-1	42	Figure 2(a)	15
GCI-2	42	Figure 2(a)	35
GCI-3	42	Figure 2(a)	50
GCI-4	43	Figure 2(b)	15
GCI-5	43	Figure 2(b)	35
GCI-6	43	Figure 2(b)	50
GCII-1	66	Figure 2(a)	15
GCII-2	66	Figure 2(a)	35
GCII-3	66	Figure 2(a)	50
GCII-4	59	Figure 2(b)	15
GCII-5	59	Figure 2(b)	35
GCII-6	59	Figure 2(b)	50

**5. Results and discussion**

Twelve slender column results reported in the literature [8] were used to validate the theoretical analysis described before. Figure 4(a) and Figure 4(b) show the experimental and theoretical load versus deflection curves for GCI and GCII series respectively.

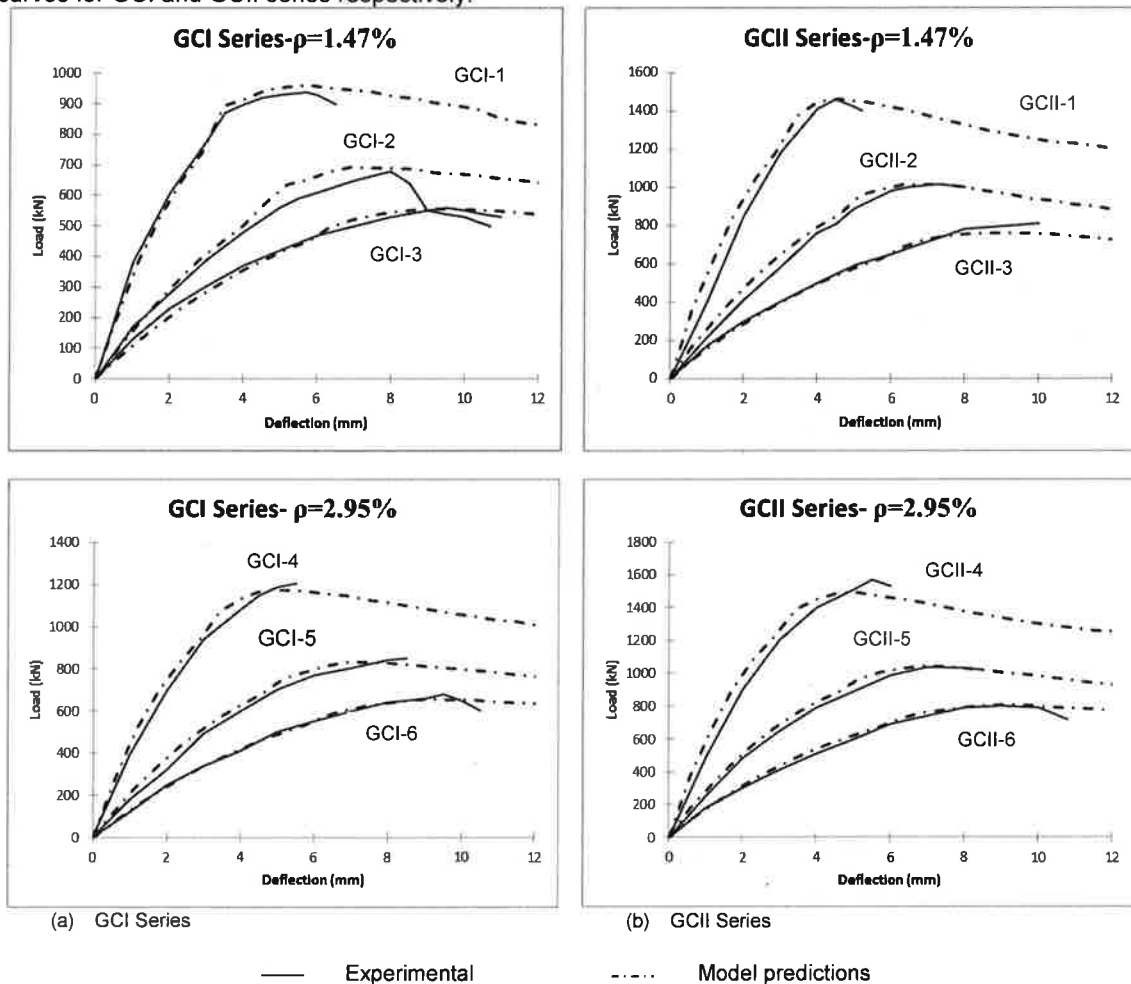

**Figure 4. Load versus deflection curves for GPC slender columns**

The analytical procedure was capable of predicting the ascending branch as well as the descending branch for all the twelve curves while a short post peak behavior is observed in majority of the experimental curves. Model predictions are in reasonable agreement especially for GCI series (low compressive strength) and for higher eccentricity values irrespective of the compressive strength. The load capacity of slender geopolymer concrete columns considerably decreases with increasing eccentricity for both experimental and model predictions. The predicted peak load and the corresponding deflection are always matching well with the experimental results. There are small variations in the ascending branches of GCII series (higher compressive strength). This needs to be investigated further with more experimental results in the future. The discrepancies between the experimental results and the model predictions may be due to the assumed sine wave function for the deflected shape.

## 6. Conclusions

The proposed constitutive relationship for confined/unconfined geopolymer concrete and the proposed analytical procedure to establish the load-deformation behaviour for eccentrically loaded slender geopolymer concrete columns compare well with the experimental results reported by Sumajouw et al. [8]. Conclusions resulted from this research are summarized below:

- The stress-strain relationship originally proposed by the authors for normal and high strength concrete [20] can be modified slightly and used for confined geopolymer concrete. It has been effectively used in the analysis of eccentrically loaded slender columns as it reflects both axial and lateral strain of confined geopolymer concrete.
- Proposed analytical procedure uses the confining pressure applied by the lateral steel which changes with lateral dilation of geopolymer concrete.
- With the increasing eccentricity, the strength of GPC columns decreases rapidly which is consistent with the experimental results as well as for NSC and HSC.
- Proposed analysis has good practical implications because the proposed model which was originally based on triaxial tests is more likely to work for a wide range of column configurations and sizes.
- The results discussed here for the slender columns not only depend on the moment-curvature of cross section, but also on curvature-deflection relationship of the column. The simplified sine-curve relationship is likely to have contributed to the slight discrepancies between the results which needs further investigation.

## 8. References

1. Rangan, B.V., *Fly ash-based geopolymer concrete*, in *Research Report GC4 2008*, Curtin University of Technology: Perth, Australia. p. 44.
2. Wallah, S.E., *Creep behaviour of fly ash-based geopolymer concrete*. Civil Engineering Dimension, 2010. **12**(2): p. 73-78.
3. Sofi, M., et al., *Engineering properties of inorganic polymer concretes (IPCs)*. Cement and Concrete Research, 2007 **37**: p. 251-257.
4. Reed, M., W. Lokuge, and W. Karunasena, *Fibre-reinforced geopolymer concrete with ambient curing for in situ applications*. Journal of Materials Science, 2014. **49**: p. 4297-4304.
5. Pan, Z., J.G. Sanjayan, and B.V. Rangan, *Fracture properties of geopolymer paste and concrete*. Magazine of Concrete research, 2011. **63**(10): p. 763-771.
6. Olivia, M., and Nikraz, H., *Properties of fly ash geopolymer concrete designed by Taguchi method*. Materials and Design, 2012 **36**: p. 191-198.
7. Diaz-Loya, E.I., E.N. Allouche, and S. Vaidya, *Mechanical properties of fly ash-based geopolymer concrete*. ACI Materials Journal, 2011. **108**(3): p. 300-306.
8. Sumajouw, D.M.J., Hardjito, D. and Wallah, S.E., *Fly ash-based geopolymer concrete: study of slender reinforced columns*. Journal of Materials Science, 2007. **42**: p. 3124-3130.
9. Sarker, P.K., *Analysis and geopolymer concrete columns*. Materials and Structures, 2009. **42**: p. 715-724.

10. Rahman, M., Sarker, P.K., *Geopolymer Concrete Columns under Combined Axial Load and Biaxial Bending*, in *CONCRETE 2011 Conference 2011*, The Concrete Institute of Australia: Perth Western Australia.
11. Sheikh, S.A. and S.M. Uzumeri, *Analytical model for concrete confinement in tied columns*. Journal of the Structural Division, Proceedings of the ASCE, 1982. **108**(12): p. 2703-2722.
12. Mander, J.B., M.J.N. Priestley, and R. Park, *Theoretical stress-strain model for confined concrete*. Journal of Structural Engineering, 1988. **114**(8): p. 1805-1826.
13. Cusson, D. and P. Paultre, *Stress-strain model for confined high strength concrete*. Journal of Structural Engineering, 1995. **121**(3): p. 468-477.
14. Kent, D.C. and R. Park, *Flexural members with confined concrete*. Journal of the Structural Division, Proceedings of the ASCE, 1971. **97**(7): p. 1969-1990.
15. Sargin, M., *Stress strain relationship for concrete and the analysis of structural concrete sections*. 1971(Study No.4).
16. Popovics, S., *A numerical approach to the complete stress-strain curve of concrete*. Cement and Concrete Research, 1973. **3**(5): p. 583-599.
17. Ganesan, N., et al., *Stress-strain behaviour of confined geopolymer concrete*. Construction and Building Materials, 2014. **73**: p. 326-331.
18. Haider, G.M., J.G. Sanjayan, and P.G. Ranjith, *Complete triaxial stress-strain curves for geopolymer*. Construction and Building Materials, 2014. **69**: p. 196-202.
19. Mander, J.B., M.J.N. Priestley, and R. Park, *Theoretical stress-strain model for confined concrete*. Journal of Structural Engineering, ASCE, 1988. **114**(8): p. 1804-1826.
20. Lokuge, W.P., Sanjayan, G.J. and Setunge, Sujeeva, *Stress strain model for laterally confined concrete*,. Journal of Materials in Civil Engineering, ASCE, 2005. **17**(6): p. 607-616.
21. Rangan, B.V., *Strength of reinforced concrete slender columns*. ACI Structural Journal, 1990. **87**(1): p. 32-38.