



# Change in the cotton harvesting system

## **A review and implications for the John Deere 7760 cotton picker**

N.P. Woodhouse

J.McL. Bennett

T.A. Jensen



**NCEA**

National Centre for  
Engineering in Agriculture

NCEA Publication 1004960/13/1  
National Centre for Engineering in Agriculture  
University of Southern Queensland  
Toowoomba, Queensland, Australia, 4350

Printed in November 2013 by the National Centre for Engineering in Agriculture, Toowoomba. Material from this publication is subject to copyright and may not be used, in whole or part, unless formal acknowledgement to the research institution is made.

***This document should be cited as follows:***

Woodhouse, N.P., Bennett, J.McL., Jensen, T.A. (2013) *Change in the cotton harvesting system: A review and implications for the John Deere 7760 cotton picker*. National Centre for Engineering in Agriculture Publication 1004960/13/1, USQ, Toowoomba.

***Acknowledgements***



Australian Government  
Cotton Research and  
Development Corporation

This work was funded by Cotton Research & Development Corporation (CRDC) as a component of CRDC Project: NEC 1301.

## Contents

Introduction .....	5
The effect of increasing cotton harvest rate .....	7
Increase in machine weight is the cost of a non-stop harvest.....	11
Soil compaction.....	14
Australian grower perspective of the John Deere 7760 .....	24
Towards an informed decision making framework.....	27
Conclusion.....	30
References .....	31

## List of tables

Table 1. Yield loss and calculated lost potential from the effect of soil compaction on grain yield due to in-field traffic associated with harvest; based on Neale (2010) .....	18
Table 2. Summary of emerging themes for the discussion forums held in the Australian cotton industry ordered in terms of key discussion points. Total participants for the five forums was twelve (Freq., frequency; frequency of response N=12). .....	26
Table 3. Round cotton modules ginned by region and year since the 2008 inception of the John Deere 7760 on-board module builder picking system in Australia. (Data sourced from: Vanderstok, 2012) .....	27

## List of figures

Figure 1 The effects of mechanisation over time. (A) Fuel use for difference components of cotton harvest - '+' is first picking; '●' is second picking, 'C' combined first and second; and, 'H' is the conventional handling system. Fuel use of the OBMB is not known. (B) Cost of harvest for the different systems. The conventional cost is well established, the CIH OBMB is limited and the JD OBMB is estimated by (Kulkarni et al. 2008) and Parvin and Martin (2005). (C) Field efficiency over time has not changed for the conventional system ('●'). The CIH OBMB (diamond) and the JD OBMB (square) have broken the 75% barrier. (D) EC is clearly the greatest effect of advances in mechanisation allowing the effort of one person to achieve greater output. Fuel use, cost per acre and field efficiency (FE) were taken directly from the literature, while effective capacity (EC) was calculated from FE and ground speeds.....	7
Figure 3 The top ten producers of cotton showing the amount of machine picking compared to hand picking. This shows the key market for the cotton pickers although approximately 30% of US production comes from Texas, which has 85% adoption of strippers. Data for this graph comes from 1997. ....	9

Figure 2. Yield comparisons of the 3 main regions in the US to Australian yields. Cotton production in the West of the US is very similar to Australia in yield and total tonnes (434 000 tonnes average 1965-2011 for West US to 492 000 tonnes average 1992 to 2012). ..... 10

Figure 4. Constraints of the cotton picker faced by manufactures. Three factors are involved: speed of the spindles relative to ground; speed of the surface of the spindle to attach to the cotton; and, rotational speed which potentially tangle cotton..... 11

Figure 5. A scale drawing reproduced from Deere & Co (2012) used to estimate axle loads as the baler forms two round bales (Figure 6). The centre of the first bale was measured as 3.89 metres from the front wheel and the centre of the rear bale to be 7.48 m. Other dimensions in the picture are A 10.1 m; B 5.25 m; C 3.81 m; and, D 4.32 m ..... 12

Figure 6. The axle load for the front and rear axle, calculated from the scale drawing in Figure 5. By the time a second bale is formed, the rear axle is carrying 83% of the load on the front axle; and 45% of the total load of the machine. The axle loadings in this chart would be the worst-case scenario when the machine is full of grease, water, fluid, fuel and carrying 5 rolls of wraps. ... 13

Figure 7 The difference in rear wheel sizes between the JD7760 (back) and a conventional picker (foreground) taken from (McVeigh 2010). ..... 14

Figure 8. Isotropic compression diagram as described by (O'Sullivan, Henshall & Dickson 1999) where the mean normal stress is considered the driving compaction force. Compaction, or change in the specific volume ( $v$ ), is considered a logarithmic function of the mean normal stress characterised by a rebound/recompression parameter ( $K$ ) and a plastic compression parameter ( $\lambda$ ), with the hashed line representing the precompression stress ( $P_c$ ). ..... 15

Figure 9 Crabbing: how a sugar beet harvester avoids multiple wheelings in the same pass. The sugar beet production system benefits from wheeling the entire width of a pass and spreading its load over three or four axles rather than concentrating the load to tracks. .... 17

Figure 9. Schematic depiction of a solid cotton system planted in 12 m frontages at 2 m machine centres and harvested using a 4 row conventional picker in comparison to a John Deere 7760 picker. The hashed lines demonstrate impact of using a dual wheeled tractor for planting. Note that the JD7760 dual wheel spacing is not aligned with furrow centres and encroaches on cotton hills of rows 2, 5, 8 and 11..... 21

Figure 10. Summary of impacts of incorporating the John Deere 7760 on-board module building cotton picker into the Australian conventional cotton system drawn from the Australian perspective and literature. .... 28

## Introduction

As a country's wealth increases the impact of labour costs rise above those of capital and land, seeing smaller farms purchased by larger operators (Hazell & Wood 2008). Increased land area increases management requirement, which when coupled with reduced staff levels strains harvest productivity and creates a need for higher capacity machines. Farmers, who want to maintain their industry effectiveness and productivity (Abeels 1983) in the face of an increasingly expensive and diminished labour force, demand larger equipment with higher capacity (Flowers & Lal 1998; Wood et al. 1993). Since the inception of machine based cotton pickers, man hours to pick a bale of lint cotton have decreased to approximately eight minutes with the current innovation of the on board module building (OBMB) picking machines (*Cotton and Wool Yearbook Data Sets* 2010; Kocher et al. 1989), which is a vast improvement from 50-70 hours picking by hand (Narayanan 2005).

Adoption of the spindle picker in the United States (US) occurred from west to east of the cotton belt mainly because the southeast had an established manual labour harvest system that worked whereas the west did not. In the West where yields were higher, the potential to grow cotton was limited by labour, so the industry was small. However, with the introduction of cotton-picking machines, this limit was overcome and rapid adoption of the cotton-picking machines drove the industry (Heinicke & Grove 2008). Conversely, the picker did not offer the same benefit to the South since labour was needed for three seasonal peaks; planting, weeding and harvest required that ordinary workers were given a share of the profit in a share-farming type setup to entice them to stay all year (Holley 2003). There was no alternative for weeding at the time; meaning machine picking would have negatively impacted the system almost to failure. In the West there was less risk as they could manage their weeds with timely irrigations in the dry, arid climate. The cotton stripper, as opposed to the more expensive cotton picker, was adopted in Texas instead because lower yields did not warrant the more expensive machine and the stripper provided a higher harvest rate, although increased contamination of lint yield with cotton trash. The picker also, but to a lesser extent, increased the level of plant trash accompanying cotton fibre to the gin, instigating a plant breeding program in subsequent years designed to favour machine picking (Hughes, Valco & Williford 2008). A plant breeding program was instigated for stripping also but focused on creating smaller plants with tighter boll conformations (Porter et al. 2012). Such breeding actually made handpicking more difficult, resulting in a more complete adoption of machine picking and increased pressure on gins. The creation of the field based module building system (MBS) reduced gin downtime and removed this pressure, but created a dangerous work environment.

Whilst it is recognised that automation and innovation are requirements of a successful and competitive industry, the flow on effect from the cotton picking machine revolution produced numerous system impacts with mixed effects.

Obvious benefits (faster picking, ability to manage greater land area) were accompanied by latent problems (available workforce decrease, gin downtime, safety issues). The cotton system in its current day is not immune to latent effects from innovative machinery. What is required is a means by which to identify these and plan for them prior to mass adoption of the technology.

In most modern cropping systems in the world, machines are becoming heavier to cope with larger land areas and accelerate processes to reduce risk associated with climate uncertainty and create time efficiencies. The cotton production system is no exception but cotton pickers may feature more design constraints than other systems. A major factor is the pickers turning time, and since cotton pickers can only pick parallel to the planting direction turning space is limited—especially for irrigated fields. Therefore the turning circle has to be small and this is made possible by maintaining a short wheelbase and narrower rear track width (Deutsch, Haverdink & Pearson 2001; Longoria 2013). The latest cotton picker from John Deere (JD) utilises an OBMB (the JD7760), as opposed to the more conventional boll basket, weighing about 36 Mg fully loaded with a rear axle load reaching approximately 16.5 Mg. This has had numerous implications for JD, including increasing rear wheel size, repositioning the engine and raising the chassis. Whilst these machines are designed to increase the harvest rate and create efficiencies in the system, they are approximately 50% heavier than the conventional basket based cotton pickers (Deere & Co 2006; Deere & Co 2012). As the weight of a machine increases, so too does the potential to cause soil compaction, which is one of the most insidious and widespread forms of soil degradation (McGarry 2003) affecting 68 million hectares worldwide, as reported by Flowers and Lal (1998). In Australia, the cost of soil compaction in lost agricultural production is approximately AUD\$850 million per year (Walsh 2002) which raises concerns for heavy machines with large physical footprints. However, these machines have been rapidly adopted in the Australian cotton industry with approximately 35% of the 2010/2011 cotton ginned picked by a JD7760 OBMB increasing to 70% of cotton ginned in the 2011/2012 season (Houlahan 2012; Vanderstok 2012). The machines have been labelled a revolution in cotton picking, but their impacts for the cotton system are not completely understood and provide an interesting case study to discuss the impacts of large, heavy machines on agricultural systems.

Hence, this review examines the impacts of increasing cotton harvest rate and highlights implications for the JD7760. In particular, this review investigates why machine weight needs to be increased to meet consumer demand and evaluates the potential for soil compaction by looking at other industries. This information is complimented by perspective on the JD7760 cotton-picking system provided by Australian cotton growers.

## The effect of increasing cotton harvest rate

The harvest rate of cotton pickers has increased with harvest frontage width from 0.35 hectares per hour for a two-row cotton picker to 3.5 hectares per hour for a six row OBMB. This is shown in Figure 1, which has been compiled from past research (Chen & Baillie 2009; Deere & Co 2006; Kocher et al. 1989; Kulkarni et al. 2008; Laws 2008a; Parvin & Martin 2005; Renoll 1979; Willcutt 2011; Willcutt & Barnes 2008; Willcutt et al. 2009; Willcutt et al. 2010).

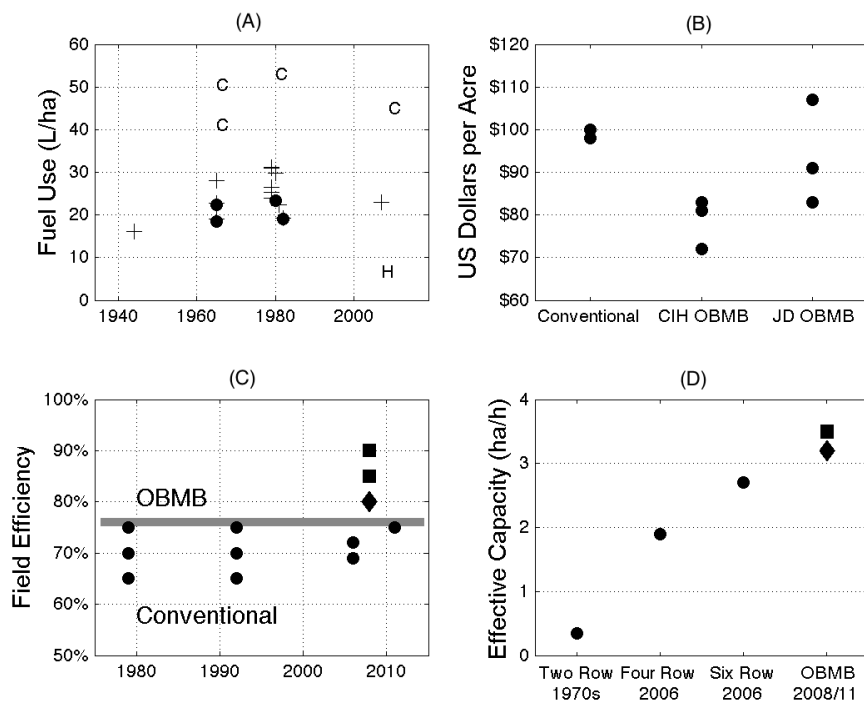

Figure 1 The effects of mechanisation over time. (A) Fuel use for difference components of cotton harvest - '+' is first picking; '●' is second picking, 'C' combined first and second; and, 'H' is the conventional handling system. Fuel use of the OBMB is not known. (B) Cost of harvest for the different systems. The conventional cost is well established, the CIH OBMB is limited and the JD OBMB is estimated by (Kulkarni et al. 2008) and Parvin and Martin (2005). (C) Field efficiency over time has not changed for the conventional system ('●'). The Case IH OBMB ('◆') and the JD OBMB ('■') have broken the 75% barrier. (D) EC is clearly the greatest effect of advances in mechanisation allowing the effort of one person to achieve greater output. Fuel use, cost per acre and field efficiency (FE) were taken directly from the literature, while effective capacity (EC) was calculated from FE and ground speeds

During this period of engineering to increase harvest rate, fuel and harvest costs have largely remained constant despite efficiency gains and are clearly unlikely to be drivers of adoption. In contrast, the effective capacity (EC), and the contributing factors, is demonstrated as the primary driver of machine innovation (Figure 1). The effective capacity (EC) is the area of a field harvested per hour including unproductive time such as turning, unloading and maintenance and is a product of the theoretical capacity (TC) and field efficiency (FE) (Mamster 2003; Eq. 1):

$$EC = FE \times TC \quad (\text{Eq. 1})$$

where, TC is the potential harvest rate if time spent not picking was ignored, and FE is the ratio of EC to TC as a percentage.

Throughout history, the demand for increasing EC has impacted the cotton production systems in several ways. In the 1940s on the high yielding west coast of the US the cotton spindle picker rapidly replaced hand picking (Heinicke & Grove 2008). The machines addressed labour issues: namely the fact labour was required for harvest; was problematic requiring management; restricted the expansion of cotton acreage due to dry conditions; and, reduced the use of irrigation to control weeds (Grove & Heinicke 2003; Heinicke & Grove 2008). As a direct result of adoption, incomes, farm sizes and productivity increased, which are perceived benefits of increasing EC.

Conversely, adoption in the South East of the US was slow largely because a share-farming system to ensure a labour force was existent for the three peak workforce requiring periods of the season. The South East was also well established, as the area was the original cotton growing region in the US and the climate allowed for rain fed systems (Street 1955; Vickers 1999). Established and functional systems are often hesitant in adoption – if it isn't broken why fix it? Share farming was essentially a system where farm owners would share the profit with the ex-slaves and poor whites, promoting spirit and creating a relatively happy, reliable and permanent labour supply for the times. The region was tailored for hand picking through the natural climate, the small land holdings and because at the time there was no other control of the characteristic weed growth in that area. The picker was not adopted due to fear the cotton growers would lose labour for weeding and also planting (Heinicke & Grove 2008; Musoke & Olmstead 1982). During the 1960s and 70s, herbicide development coincided with rising wages (Holley 2000), possibly due to technological change leading to economic growth, with factories in cities more able to compete with farm owners. This created a push pull effect on the millions of cotton workers towards the cities with a range of 20–40% push, 80–60% pull (Holley 2003; Peterson & Kislev 1986). Whilst the impacts of mechanisation in the West were largely positive, in the South, the debate continues as to whether the cotton picker was or was not the main cause of the mass exodus of workers from the cotton field (Grove 2002).

In the US, between 1955 and 1965 adoption of cotton pickers went from 12% to 100% and ginneries were struggling to cope with the influx of machine picked cotton. The gin had become the hindrance to the harvest chain and farmers began to dump cotton at the ends of the rows (and later bins) to allow picking to continue (Anthony & Mayfield 1995). In the late 1960s the cotton caddy and the cotton ricker became the first devices to form a free-standing stack of cotton (Anthony & Mayfield 1995). However, these free standing stacks were inefficient in comparison to the later developed MBS (or the conventional system) developed by Cotton Incorporation in 1973 (Wilkes & Wilkes 1973). Complete adoption of the MBS did not happen until four row cotton pickers increased the



productivity in the 1980s and, while it was successful in removing the gin as a major impedance (Willcutt et al. 2009), it also increased the risk of injury from an occupational health and safety perspective (OH&S). In Australia from the 1997/8 season to 2005/6 season the MBS was responsible for 723 workers compensation claims (at an average of 80 per year) and claimed 4 lives (Fragar & Temperley 2011).

In all regions, as the cotton picker was first adopted, increased EC appears to benefit cotton production systems and outweigh the potential reduction in profit from trash content of cotton lint delivered to gins. Mechanical picking introduced trash to the gin (Hughs, Valco & Williford 2008) and removing further downgrades the cotton due to tangles and broken fibre (Williford, Meredith Jr & Anthony). However, just as social security in the US, and Government pensions in Australia, helped overcome some of the problems of labour loss in regional areas (Grove 2002), years of plant breeding and development of chemicals like defoliant changed the cotton plant to suit machines (Street 1955). In manipulating the plant physiology to favour machines, hand picking hard became much harder, which accelerated the adoption process where machine harvest was an option (Musoke & Olmstead 1982). Whilst hand picking is the slowest method, it is the cleanest in terms of trash and cheapest in terms of initial capital outlay. Thus, it is common in developing countries (Chaudhry 1997; Narayanan 2005) and is still the dominant method worldwide at 70–80% (Figure 2). Comparatively, stripping is the fastest but most unclean, and picking is the compromise between speed and a clean pick (Keeling et al. n. d.).

The cotton growing conditions in Australia are very similar to the environmental conditions in the West of the US and as such, the yields for the two regions are also very similar (Cotton and Wool Yearbook Data Sets 2010; ABS 1993-94, 2003, 2004, 2007, 2009-10, 2011-12, 2012) and especially adoption rates of innovative picking technologies (Houlahan 2012; Musoke & Olmstead 1982). Differences between the JD7760 picking system front and the conventional picking system front are minimal; the main gain in harvest efficiency comes from the JD7760 not having to stop to unload into boll buggies (Willcutt et al. 2009). This feature has dramatically reduced the labour required as shown in a few US farms where four staff can now do the work of 24 on one 14 000 acre property (Laws 2008a) and a reduction of three staff on a 2 500 acre property (Laws 2008b). These studies, while conducted early in the adoption phase and mainly concerning Case IH (CIH) Module Express

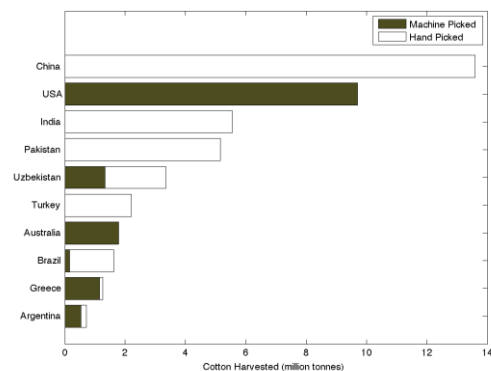

Figure 2 The top ten producers of cotton showing the amount of machine picking compared to hand picking. This shows the key market for the cotton pickers although approximately 30% of US production comes from Texas, which has 85% adoption of strippers. Data for this graph comes from 1997.

625 pickers, show a reduction in labour demand of of 1.2 to 1.5 workers per 1000 acres for the harvest season. On average one boll buggy and one module builder are required for every 6 rows of cotton harvest, meaning the OBMB is responsible for a loss of about 1.2 tractors per 1000 acres (Parvin & Martin 2005). Higher yields in Australia means 6 rows of cotton picking requires 1.5 boll buggies and 2.5 module builders on average and the reduced labour demand has been between 2 and 4 people per 1000 acres (JD7760 discussion forums, Pers. Comm. 2013). Another impact of the OBMB, in particular the JD7760, is that now cotton is presenting a larger variation in moisture to ginners due to the smaller size allowing cotton picked at different times during the day to be mixed (Houlahan 2012). Also, there is less mixing of cotton in the JD7760 compared to the conventional system, which stored cotton in a basket for some time before transferring it either into a boll buggy or directly into a module builder and received multiple compressions (Willcutt et al. 2010). The JD7760 compresses the cotton just once and very soon after it has been picked so not only is there is less chance of airing (Willcutt et al. 2010) but more chance infield variation replicating in a round module instead of being spread across the full length of a large rectangular module. Other impacts to be identified thus far include the high cost of wrap exaggerated by the higher yields in Australia; a fluctuating Australian dollar; and, transport difficulties of the picker itself (due to the weight and size) (Houlahan 2012; Vanderstok 2012).

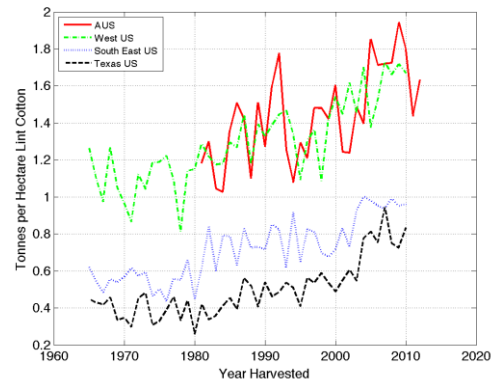

Figure 3. Yield comparisons of the 3 main regions in the US to Australian yields. Cotton production in the West of the US is very similar to Australia in yield and total tonnes (434 000 tonnes average 1965-2011 for West US to 492 000 tonnes average 1992 to 2012).

It is apparent that to increase the EC, machine efficiencies and automation of process present an obvious potential to industries. However, while there are obvious direct benefits such as increased productivity, there are more latent effects on the system such as decreased workforce availability, safety and impacts on regional social capital. The cotton industry has been resilient and innovative in addressing impacts and strengthening the cotton production and processing system, but this has been ad hoc and reactive, rather than structured and mitigative. Early identification of technological likely effects on cotton production and processing systems would help to optimise systems prior to mass adoption.

## Increase in machine weight is the cost of a non-stop harvest

The most recent leap in EC has come from the adoption of the OBMB. Just as the spindle picker took 90 years to develop from its initial conception in 1850 (Rembert 1850) to functional machines in the 1940s (Holley 2000; Peterson & Kislev 1986; Rust 1933), the OBMB has taken similar steps. Patents have shown that thoughts to compress cotton on board begun as far back as 1919 with an all-in-one picking and ginning machine (Silverthorne 1919) and have continued in the 1950s (Wagon 1956) and 1960s (Nickla 1965, 1968). However, the soft and fluffy nature of cotton has caused problems for machine designers over the years and has resulted in development of augers to compact cotton on harvesters (Deutsch 1989). It was this concept that led to the first OBMB design in the 1980s, consisting of an auger with a diameter of about 1.5 metres and two module chambers (Fachini & Orsborn 1985). The two commercially available OBMBs for JD and Case International Harvester (CIH) took shape in 2000 and 2003 (Covington et al. 2003) respectively with JD combining the cotton picker with a long history of proven design in the hay baler (Gola, Basile & Deutsch 2000; Viaud 1990) and CIH using the proven concepts of the module builder (Gola, Basile & Deutsch 2000). Due to the automated module forming process, they have successfully improved the OH&S of the cotton harvest system. However, while EC has been the focus, like machinery in most farming systems (Gysi, Klubertanz & Vulliet 2000; Heuer et al. 2008), the new OBMBs are extremely heavy in comparison to the conventional basket pickers they replace.

The most recent leap in EC has come from the adoption of the OBMB. Just as the spindle picker took 90 years to develop from its initial conception in 1850 (Rembert 1850) to functional machines in the 1940s (Holley 2000; Peterson & Kislev 1986; Rust 1933), the OBMB has taken similar steps. Patents have shown that thoughts to compress cotton on board begun as far back as 1919 with an all-in-one picking and ginning machine (Silverthorne 1919) and have continued in the 1950s (Wagon 1956) and 1960s (Nickla 1965, 1968). However, the soft and fluffy nature of cotton has caused problems for machine designers over the years and has resulted in development of augers to compact cotton on harvesters (Deutsch 1989). It was this concept that led to the first OBMB design in the 1980s, consisting of an auger with a diameter of about 1.5 metres and two module chambers (Fachini & Orsborn 1985). The two commercially available OBMBs for JD and Case International Harvester (CIH) took shape in 2000 and 2003 (Covington et al. 2003) respectively with JD combining the cotton picker with a long history of proven design in the hay baler (Gola, Basile & Deutsch 2000; Viaud 1990) and CIH using the proven concepts of the module builder (Gola, Basile & Deutsch 2000). Due to the automated module forming process, they have successfully improved the OH&S of the cotton harvest system. However, while EC has been the focus, like machinery in most farming systems (Gysi, Klubertanz & Vulliet 2000; Heuer et al. 2008), the new OBMBs are extremely heavy in comparison to the conventional basket pickers they replace.

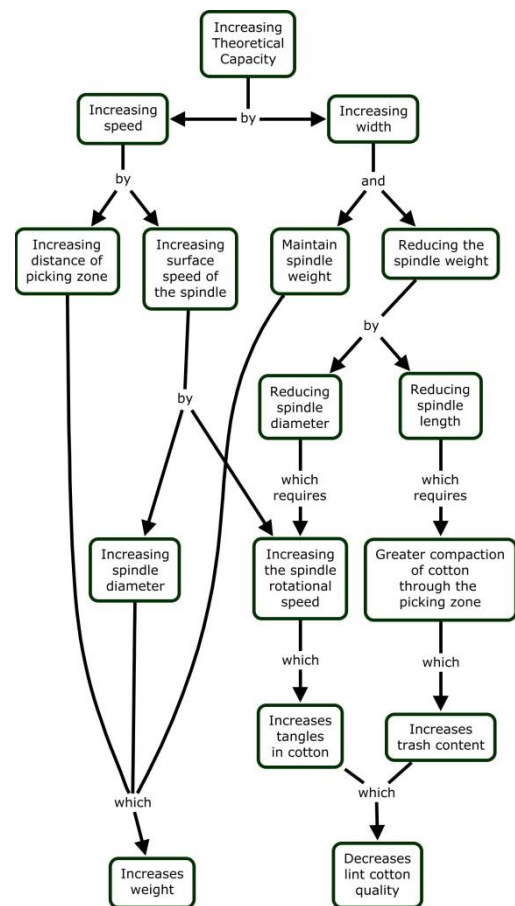

Figure 4. Constraints of the cotton picker faced by manufactures. Three factors are involved: speed of the spindles relative to ground; speed of the surface of the spindle to attach to the cotton; and, rotational speed which potentially tangle cotton.

The increase from a two-row picker to a four-row picker revealed some design constraints of cotton pickers that manufacturers face, mainly manifesting in spindle size and speed of machine travel (Figure 4). If increasing the ground speed the speed of the row of spindles need to increase to maintain a zero velocity relative to the cotton plant. The rotational speed of the surface of the spindle also needs to increase so the barb can continue to attach to the cotton fibre and remove it from the plant (Willcutt et al. 2010). This can be done either

by increasing the revolutions per minute (RPM) of the spindle or increasing its diameter. Increasing the diameter increases the weight, which is not desirable mainly for keeping the material costs low so increasing the RPM becomes the desirable option. The drawback, shown in research as recent as 2004 (Armijo et al. 2006; Baker et al. 2004), is that higher RPM decreases lint quality through higher counts of short fibre and tiny knots, called neps, and the number of these doubles for every 1000 RPM increase. In the experiments undertaken by Baker et al. (2004) the counts after cleaning were less noticeable in comparison to controls, but still significant given ginning has a similar effect when removing trash (Columbus, Bel & Robert 1990).

A second method by which to increase the TC is to increase the width. Since the concept of the spindle system is robust and is almost unchanged from since the 1940s (Key 1985) widening the machine is simple. However, decreasing the weight is essential for optimising the cost of the machine and increasing the length and diameter of the spindle achieves this (Key 1985). CIH could not widen their two-row cotton picker to four rows without doing this. The drawback of this are twofold: with shorter spindles, cotton needs to be compressed more to ensure contact with the barbs and this adds trash to the seed cotton; and decreasing the spindle diameter requires an increase in the spindle RPM, which is discussed above. So, to design a faster machine, the quality of the cotton and the weight need to be considered.

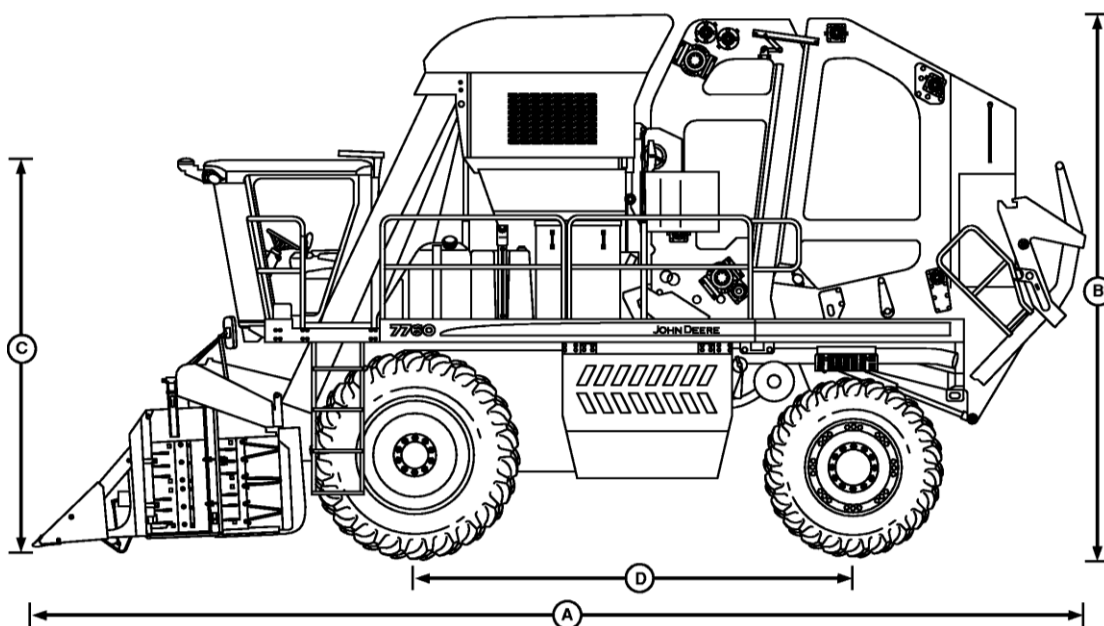

Figure 5. A scale drawing reproduced from Deere & Co (2012) used to estimate axle loads as the baler forms two round bales (Figure 6). The centre of the first bale was measured as 3.89 metres from the front wheel and the centre of the rear bale to be 7.48 m. Other dimensions in the picture are A 10.1 m; B 5.25 m; C 3.81 m; and, D 4.32 m

While the added OBMB has dramatically reduced the unloading time for the JD7760 and increased the FE, it has added 12 Mg to the machine including another 10 Mg over the rear axle (Wattonville 2008). Axle loads of the JD7760 can be estimated using the field ready, starting weight of 32 Mg (taken from Deere & Co 2012), which includes the weight contribution of fluid, five rolls of wrap, dual wheels and 6-row pro 16 picking head, and by applying a force and moment equilibrium analysis via estimating the position of round cotton modules from the scale drawing in Figure 5. During formation of the initial round bale, the front axle load was found to be mostly stable at 21.5 Mg and decreases to about 19.9 Mg as a round bale is moved to the rear platform. The rear axle's weight was found to be more dynamic starting at 10.6 Mg when empty to 12.8 Mg when the first round bale has formed and changing from 14.5 Mg to 16.5 Mg as a second round bale forms. The absolute maximum weight of the working machine fully loaded with cotton based on a round module weight of 2.27 Mg (Deere & Co 2012), ignoring cotton in the accumulator and any aftermarket modifications, is calculated at 36.5 Mg (Figure 5).

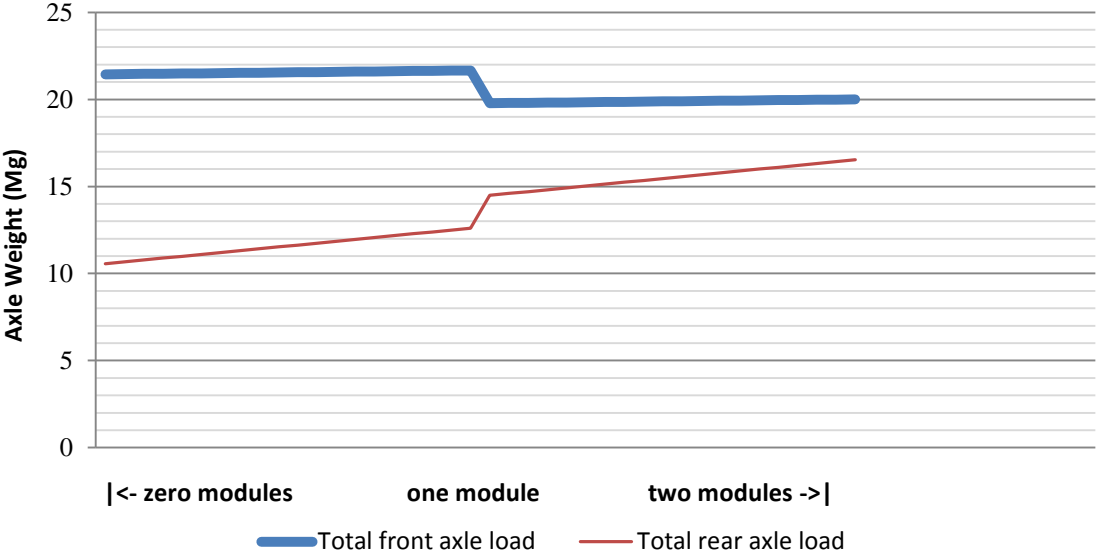

Figure 6. The axle load for the front and rear axle, calculated from the scale drawing in Figure 5. By the time a second bale is formed, the rear axle is carrying 83% of the load on the front axle; and 45% of the total load of the machine. The axle loadings in this chart would be the worst-case scenario when the machine is full of grease, water, fluid, fuel and carrying 5 rolls of wraps.

Lengthening the machine could alleviate this dramatic increase in rear axle load, but another equally important component of FE would be affected: turning efficiency. Not only does the machine need to turn tightly to minimise turning time (Renoll 1979), it must also fit between the head ditch and the start of the row in surface irrigated agriculture. Other crops may not have this restriction, but with cotton a short wheelbase with high angle pivoting rear tyres is critical. John Deere itself has expressed difficulty in accommodating for a larger wheel and maintaining a tight turning circle having to reposition and align the engine and raise the rear wheel cavity to make room (Fox, Pearson & Bares 2009).

Increasing the wheelbase and track width requires sharper steering of the wheel to maintain the same turning circle according to the principles of vehicle system dynamics and control (Longoria 2013).



*Figure 7 The difference in rear wheel sizes between the JD7760 (back) and a conventional picker (foreground) taken from (McVeigh 2010).*

characteristic or output must be compromised, as is the case for the JD7760 where the compromise is a larger, heavier physical footprint that has the potential to detrimentally increase soil compaction.

Constraints from the cotton production system and design phenomenon have resulted in a machine that is restricted in width, length and height. Space for the addition of a module builder on board is limited resulting in much of the excess weight positioned over the rear axle. Since the development of machinery is complex and time consuming, as shown by the 90 years of spindle design and similar length of time for the OBMB, design changes, which appear simple on the outside, are extremely complex for the engineers who implement them. Therefore, some

## Soil compaction

Compaction is regarded as the most serious effect of conventional agriculture on the environment (McGarry 2003) and is one of the greatest threats to soil quality worldwide (COM, 2006; Hamza and Anderson, 2005). Given the recent trend (within the last 30 years) of increasing machine axle loading (Etana & Håkansson 1994; Flowers & Lal 1998; Gameda et al. 1987; Gysi, Ott & Flüher 1999; Håkansson et al. 1987; Raper 2005; Van den Akker & Soane 2005) to increase EC, soil compaction risk is not likely to be diminished without concerted effort and careful farming system considerations. Compaction occurs when the applied load exceeds the precompression strength of the soil, resulting in an increase in the bulk density (BD), due to the reduction of macropores that dominate soil hydraulic conductivity (HC) and infiltration (Chamen et al. 2003). When soils are dry the precompression strength is high, but this weakens rapidly as the soil moisture approaches field capacity (FC) (Van den Akker & Soane 2005) at a magnitude dictated by the clay content (Håkansson et al., 1987). Avoiding trafficking of moist soils on permanent tracks is reported as the best approach to managing compaction (Tullberg et al. 2007), but the crop dictates the timing of the harvest window, and machinery manufacturers limit the matching of wheel tracks of various machinery for a farming system. Heavy machines are used in various agricultural systems, but the importance of soil compaction as a consideration versus EC, and the subsequent methods of decreasing heavy

machine impact, differ substantially between and within agricultural systems. The following subsections discuss soil compaction from the point of view of machine traffic and investigate the potential considerations for the JD7760 through examination of heavy machines from other agricultural industries.

### **Importance of axle load in avoiding Compaction**

Danfors (1994) suggests that machine axle load is required to be less than 6 Mg (single axle) or 8 Mg (tandem axle) to minimise the risk of irreversible soil compaction occurring. Soil compaction describes the alteration of soil structure whereby the spatial arrangement, size and shape of soil aggregates changes, subsequently causing a reduction in soil macroporosity (Chamen et al. 2003; Defossez & Richard 2002). Soil compaction from traffic can be explained by soil mechanics to include an elastic, plastic deformation and failure phase (Defossez & Richard 2002), whereby the elastic phase represents reversible compression, which changes to irreversible as the plastic deformation phase is reached, and subsequently can result in complete failure (Figure 8). Whilst Figure 8 is a diagram considering soil as an isotropic medium, it demonstrates that the effects of compaction change from reversible ( $K$ ) to irreversible ( $\lambda$ ) as the compression stress exceeds the precompression stress ( $P_c$ ) value. Thus, the majority of conventional farm machinery where axle loads often exceed 10 Mg presents a concern for irreversible soil compaction considering the axle load limits suggested by Danfors (1994).

Axle loads between 10 Mg and 25 Mg, approximately the range of the axle loads for the JD7760, have been studied in the US (Flowers & Lal 1998; Lal 1996; Lal & Ahmadi 2000; Lowery & Schuler 1991; Voorhees 1986; Wood et al. 1993), Canada (Gameda et al. 1987; Gameda et al. 1994; Raghavan et al. 1978), Norway (Riley 1994), Sweden (Arvidsson 2001; Etana & Håkansson 1994; Håkansson 1985), Germany (Schäfer-Landefeld et al. 2004) and Switzerland (Gysi, Klubertanz & Vulliet 2000). These worldwide results show that soil compaction is variable, with traffic based compaction occurring at depths ranging from approximately 15 cm (Gysi, Klubertanz & Vulliet 2000; Schäfer-Landefeld et al. 2004; Voorhees 1986; Wood et al. 1993) to 60 cm in the worst cases (Håkansson et al. 1987; Voorhees 1986). Differences in axle load

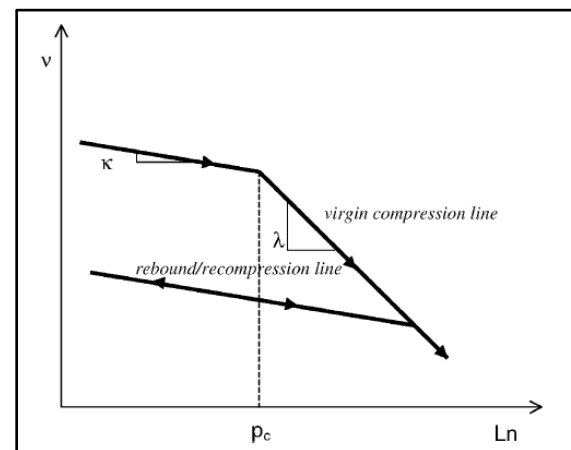

Figure 8. Isotropic compression diagram as described by (O'Sullivan, Henshall & Dickson 1999) where the mean normal stress is considered the driving compaction force. Compaction, or change in the specific volume ( $v$ ), is considered a logarithmic function of the mean normal stress characterised by a rebound/recompression parameter ( $K$ ) and a plastic compression parameter ( $\lambda$ ), with the hashed line representing the precompression stress ( $P_c$ ).

aside, compaction is also a function of soil mechanical strength, which is governed by characteristics such as clay content (texture), organic carbon content, soil water status, structure and the tilled state of the soil prior to traffic (Guérif 1984; Hettiaratchi 1987; Horn et al. 1994; Larson, Gupta & Useche 1980; O'Sullivan, Henshall & Dickson 1999). Changes in these characteristics between soils likely account for this variation in compaction depth not explained by axle load. Therefore, to truly understand the potential effect of a machine on soil compaction both the soil mechanical strength and machine loading stress should be understood (Defossez & Richard 2002), although it is simpler to predict this from the characteristics of the latter.

Keller and Arvidsson (2004) have shown that the axle load of a machine is less important than the individual wheel load in an experiment comparing dual- and tandem-wheel loads. Thus, they report soil compaction as a function of the stress on the soil surface and the contact area, which is derived from wheel load, wheel arrangement, tyre inflation pressure, contact stress distribution and soil conditions. Whilst they further state that soil compaction is not a function of axle load or total machine load, these loads affect wheel load. That is to say, axle load and total machine load indirectly affect soil compaction, but that wheel load more accurately describes the potential for soil compaction. Tyre dimensions, as well as inflation pressure, are well documented as characteristics that affect the compaction potential of a soil (Berisso et al. 2013) and reducing or preventing high axle loads not only avoids compaction at depth but allows lower inflation pressures to be used. Low tyre inflation pressure reduces contact pressure and hence compaction at the surface (Heuer et al. 2008). Using smaller machinery or increasing the number of axles are ways of reducing axle load (Keller and Arvidsson 2004), but not possible for many situations. The effect of contact pressure on soil compaction disappears at 40 cm in some circumstances (Wood et al. 1993), so high contact pressure is generally associated with topsoil compaction (TSC). Increasing the diameter of a tyre theoretically decreases contact pressure, but Raper (2005) found that tyre stiffness increased with increasing tyre height—wide tyres and dual wheels are then more successful options to increasing diameter, but this increases the soil surface area traversed.

A further consideration is the use of tracked machines. Ansorge and Godwin (2008) conducted a series of experiments in soil bins comparing rubber track assemblies to wheels and found when tracks were simulated for a 33 Mg axle load soil deformation was similar to that of an axle load of 11 Mg for a wheel. The peak contact pressure can be 1.5 times the average contact pressure under tyres and 2–4 times higher under tracks (Van den Akker & Soane 2005). Hamza and Anderson (2005) found metal tracks are more damaging than radial tyres, although rubber tracks were comparable. In either case, tracks also exert a force for longer (Demmel, Brandhuber & Geischeder 2008) and the assembly adds weight to the machine (Arvidsson et al. 2011). On the other hand, when a draft force is required, tracks offer high tractive force with much less damaging wheel slip, as compared to wheeled machines (Raper 2005), but this tractive force



prevents tight turning circles. The use of tracks would therefore be detrimental to the JD7760 cotton picker and the realised gains in EC without further significant engineering resulting in probable machine weight increase (Figure 3).

### **Compaction lessons from heavy machines in the sugar beet and grain industries**

Sugar beet harvesters (SBH) can weigh more than 40 Mg fully loaded (Schäfer-Landefeld et al. 2004) with axle loads reaching between 20 and 27 Mg but the adverse effects of soil compaction appear to be limited (Arvidsson 2001; Demmel, Brandhuber & Geischeder 2008; Heuer et al. 2008; Schäfer-Landefeld et al. 2004). Instead of controlling their traffic to permanent lanes SBHs spread their load over the entire surface, avoiding multiple wheelings where possible via offset wheels, either by ridged design or crabbing (see Figure 9). This strategy allows old plough pans to support the load without leaving compaction at the surface where it is tilled. However, sugar beets may not be affected by compaction as much as other crops (Lal 1996) and earthworms appear to increase the hydraulic conductivity in the subsoil (Gysi, Ott & Flühler 1999; Schäfer-Landefeld et al. 2004). The minimal depth of compaction under SBH (to just 17 cm) is explained by Gysi et al. (1999) as due to the sand content of the soil (50%), which prevented compaction from deepening.

In a multiple location, year-long study of compaction by researchers in 29 countries, a relationship between yield loss, time after traffic and soil texture for a 10 Mg load was produced (Håkansson et al. 1987). Of importance to soil compaction under heavy machines, the yields of a range of different crops were shown to decrease rapidly as the soil clay content was increased at a constant axle load.

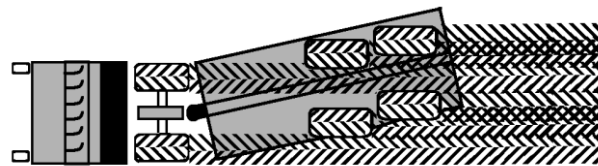

*Figure 9 Crabbing: how a sugar beet harvester avoids multiple wheelings in the same pass. The sugar beet production system benefits from wheeling the entire width of a pass and spreading its load over three or four axles rather than concentrating the load to tracks.*

Cotton in Australia is typically grown on Vertosol soils (Isbell 2002), also known as Vertisol soils (IWG 2007), as these soils dominate the Australian cotton regions (McKenzie 1998). These soils have high clay content and uniform soil profiles, and are likely higher in clay content than soils used for SBH compaction studies. Hence, while the management of SBH soil compaction advocates high surface area traffic in singular passes, this would not necessarily be a useful technique for mitigating detrimental soil compaction under heavy machines in the Australian cotton industry.

In the grain industry, recent advances in cropping system management recommend no-till and minimum tillage systems to maintain soil structure and maximise nutrient and water use efficiency, which has led to increased interest in

soil compaction effects caused by harvest systems (Botta et al. 2007). Grain harvesters are increasing in size to maximise the frontage harvested (increased EC), are typically the heaviest machine operating in the grain system paddock, and can weigh 20 Mg with an additional 7–9 Mg of grain when fully laden (Neale 2010). Potential reduction in yield for various grain crops is calculated from literature yield decline due to in-field traffic associated with harvest in Table 1. While the various data sources in Table 1 have calculated yield reduction using different methods of measurement, the data is sufficient to show that compaction has significant effect on grain yield and, from the above discussion, that reductions could be expected to be greater with heavier axle loads on high clay content soils. Chan et al. (2006) and Jensen and Neale (2001) have made their calculations on traffic affected rows in comparison to non-traffic affected rows in a controlled traffic farming (CTF) system, thereby the lost potential is calculated on the compaction yield figures only. Thus, it stands that if 100% of the paddock surface was traversed that this lost potential per hectare, in comparison to the planted hectare, would be significantly greater than if the in-field traffic were contained to permanent traffic lanes with all machine wheel tracks (distance between wheels along an axle) matched (true CTF). As a result of harvester impact on soil compaction and subsequent yield, the grain industry has pushed for the uptake of CTF as best management practice for soil productivity maintenance (Neale 2010). While the Australian cotton industry also recommends CTF (McKenzie, 1998), the information from the grains industry highlights the potential to lose production due to soil compaction.

*Table 1. Yield loss and calculated lost potential from the effect of soil compaction on grain yield due to in-field traffic associated with harvest; based on Neale (2010)*

<i>Grain</i>	<i>Average yield loss (t/ha)</i>	<i>Yield reduction (%)</i>	<i>Lost potential<sup>†</sup> (AUD\$/ha)</i>	<i>Data source</i>
Grain sorghum	0.9	50*	221	Jensen, Powell and Neale (2001)
wheat	0.75	30*	236	
Corn (maize)	0.41	30*	72	
Wheat	0.4	24	126	Braunack (2008)
Soy bean	0.79	30	379	Botta et al. (2007)
Wheat	0.7	21	221	Radford et al. (2001)
Corn	2.18	43	382	
Canola	2.1	66*	1050	Chan et al. (2006)
Wheat	0.9	15	284	Neale (2010)

\*Reduction of yield in traffic affected rows only, as compared to non-traffic affected rows

<sup>†</sup>Lots potential of commodities is calculated on mean yearly averages for the period 2009-2013 from PentAg NIDERA (Turner Pers. Comm. 2013)

## *Effect of the John Deere 7760 cotton picker on soil compaction*

The JD7760 has been designed to pick a six row cotton frontage, which is compatible with a 12 m planting system common to cotton (Figure 10). Although the JD7760 is compatible with current systems, the surface area traversed is increased, comparative to the conventional 4 row picker, in order to minimise the impact of heavy axle load by spreading it across four wheels on the front axle. If the cotton system is skip-row based to optimise water use management (Bange et al. 2005) the impact of the conventional system becomes even less by modifying the tool bar to accommodate a 6 row frontage with 4 picking heads; the wheels then align with the JD7760 wheels (Figure 10) between rows 2 and 3, and 4 and 5, for example. However, in Australia, this modification has also been undertaken on the JD7760 to allow an 8 row frontage with 6 picking heads, which is not compatible with the 12 m planting widths. According to Tullberg et al. (2011) only ~15% of farmers (all industries) use CTF in the true sense of permanent wheel tracks and matching machine centres, with many intending to implement CTF, but becoming defeated due to economics and practicalities of matching machine wheel centres. Thus, modification to an eight row frontage, 6 row pick, might be seen by growers as an efficient use of time and money for harvest, but would be detrimental to soil compaction potential. Whether using CTF, picking in skip-row or solid cotton systems, the dual wheels of the JD7760 increase the surface area traversed, as compared to conventional picking systems.

As discussed previously, the depth of compaction can be decreased and reversible if axle loads are below 6 Mg for a single axle (Danfors 1994), which translates to an individual wheel load of 3 Mg, but the JD7760 exceeds this. To combat a heavy axle load, dual wheels are used to decrease the individual wheel load for a given axle load. The axle load is approximately divided by the number of wheels to obtain wheel load, although the positioning of machine transient load can affect individual wheel loads in a non-uniform fashion. This is the premise of Keller and Arvidsson (2004) determining that wheel load is more important in calculating soil stress than axle load and that each wheel of a machine should be considered independently. In the case of the JD7760, the addition of dual-wheels results in a wheel load of ~5.38 Mg on the front axle, which decreases slightly to ~4.98 Mg as a round module is transferred to the rear haulage basket. Comparatively, the rear wheel load increases from ~5.3–8.25 Mg, due to the same process. Of note, the individual wheel load of the JD7760 approaches for all wheels, and exceeds in the rear, the total axle load of Danfors (1994) and is near double the individual wheel load of Danfors (1994). Thus, the potential for the JD7760 to cause soil compaction might be consider high. Braunack (2012) investigated the effects of the JD7760 after harvest when soils were near, or exceeding, the plastic limit using a cone penetrometer and found evidence that soil strength increased to a depth of ~60 cm for a cracking clay (likely Vertosol) and red brown clay. However, on closer inspection of the cracking clay, the major differences occurred in the 0-20 cm depth. Even though

absence of confidence measures for the data suggest a conservative interpretation of this data should be made, there appears a trend for soil strength to be slightly greater ( $\sim 50$  kPa) at all depths to 60 cm. Comparatively, a conventional basket picker was shown to cause compaction between 40 and 60 cm. Kulkarni et al. (2008) assessed the JD7760 in comparison to a John Deere 9996 (JD9996) basket picker ( $\sim 20$  Mg unloaded, 6 row frontage variant), which is also a dual-wheeled front axle machine. They measured soil strength with a penetrometer at 40 points in the direction of travel of the machines and found that both the JD7760 and JD9996 caused compaction to increase above 2000 kPa (the soil strength representing complete restriction to majority of root growth) between 5 and 15 cm within some portion of the field. Although the JD9996 exhibited a greater impact in this shallow depth in terms of soil strength, the JD7760 caused a significant increase in average soil bulk density from  $1.54 \text{ g cm}^{-3}$  to  $1.62 \text{ g cm}^{-3}$  (sample depth unreported). Kulkarni et al. (2010), using the same site, reported a trend for compaction to increase as JD7760 modules were built and carried throughout the pass of the machine from empty to the end of the field. They also showed that slight increases in soil strength due to traffic with the JD7760 occurred, but report that the data is currently insufficient to draw real conclusions about the extent of compaction, except to say that it was definitely occurring.

Using a basket picker, growers have incorporated boll buggies into the picking system to increase EC by minimising machine downtime to unload a full basket into the boll buggy; the picker can then continue without need to leave the field. Therefore, the traffic schematic in Figure 10 does not completely portray the picking system traffic, just the harvester traffic. Whilst boll buggies are not heavy vehicles, they travel alongside the picker and affect soil compaction between rows 2 and 3, and 4 and 5, for the example in Figure 10. Hence, the conventional basket picker and boll buggy cotton system does not lend itself well to true CTF systems (Tullberg 2010). Even though the addition of an OBMB to compact cotton has made the modern cotton picker in the same weight class as grain trailers (or chaser bins) and sugar beet harvesters where axle loads reach 20 Mg or more, the modern cotton picking system does away with parallel traffic from boll buggies, and limits compaction to harvester traffic lanes only. In addition, Willcutt et al. (2009) showed that the JD7760 increased FE by between 6.2 and 8.7%, when speed was kept constant at 4 miles per hour ( $\sim 6.5 \text{ km h}^{-1}$ ), as compared to the CIH625 module express and numerous conventional basket pickers. This translated to an average time saving of 2.59 min per basket picker unload instance for the JD7760. Although, the JD7760 places the  $\sim 2.27$  Mg round module directly onto the ground, which commonly occurs in-field given the length of Australian cotton fields (unpublished observations). A tractor then needs to remove the module from the field, which increases soil traffic, albeit on the same tracks, especially if the tractor reverses out of the field rather than driving through. Alternatively, some manufacturers are producing trailers for the JD7760 pickers that are capable of holding up to four round modules. Again, this increases traffic, but alleviates direct placement of modules onto the soil and

constrains traffic to lanes, which is in keeping with CTF. A trailer should also reduce the period of time the rear wheel load is elevated to 8.25 Mg by distributing the load over tandem axles on the trailer. However, trailer wheel loads need to be investigated in order to determine if this is a benefit to wheel load.

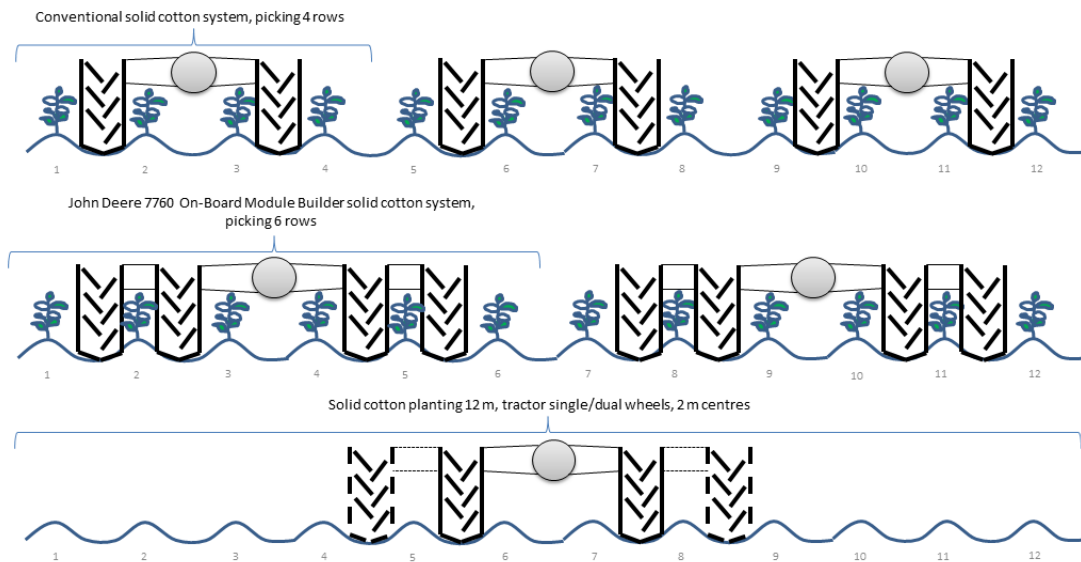

Figure 10. Schematic depiction of a solid cotton system planted in 12 m frontages at 2 m machine centres and harvested using a 4 row conventional picker in comparison to a John Deere 7760 picker. The hashed lines demonstrate impact of using a dual wheeled tractor for planting. Note that the JD7760 dual wheel spacing is not aligned with furrow centres and encroaches on cotton hills of rows 2, 5, 8 and 11.

The change from four row conventional cotton pickers in Australia has meant an increase in the machine weight for the JD7760, but this increase in weight is compromised with the removal of parallel supporting traffic for unloading of boll baskets in field. Whilst preliminary studies suggest that the JD7760 is responsible for increasing soil compaction during harvest, more information on the extent on this is needed, and it would appear that constraining traffic to permanent lanes would address this issue; i.e. CTF. The main concern for the JD7760 is the field surface area traversed due to the dual-wheeled front axle and potential wheel load. However, some innovative Australian growers have adapted their machines to suit CTF by removing a front wheel, which voids the JD machine warranty (Grant pers. comm.), and is subject to the economic and practical limitations to adoption as described by Tullberg et al. (2011). A comparison between the soil compaction effects of these dual-wheel and single-wheel variants of the JD7760 will identify potential benefits for either system, and perhaps justify CTF costs.

### Managing soil compaction

Alleviation of compaction can occur naturally in shrink and swell clays through self-mulching phenomena (Radford et al. 2001; Van den Akker & Soane 2005) and from bioactivity (Schäfer-Landefeld et al. 2004; Spoor, Tijink & Weisskopf

2003; Van den Akker & Soane 2005); freeze and thaw cycles can also alleviate soil compaction, but are not relevant to the Australian cotton industry and only penetrate the top 5 cm (Gameda et al. 1994; Van den Akker & Soane 2005). However, these processes alone may not adequately address soil compaction without sufficient fallow periods. Thus, tillage is often relied upon. Tillage can decrease the BD of a soil but cannot restructure it (Schäfer-Landefeld et al. 2004). Furthermore, during tillage the soil can be exposed to further compaction via tractors and the supply of draft forces, which become larger as compaction increases (Arvidsson, Sjöberg & Van Den Akker 2003). Implements utilising power take off instead of draft force may compact soil less. Subsoiling has been investigated to alleviate subsoil compaction (SSC), but should only be done if absolutely required (Chamen et al. 2003; Schäfer-Landefeld et al. 2004) and should aim to create fissure cracks by passing single tines under the compacted zone to bend it (Spoor, Tijink & Weisskopf 2003). Subsoiling to alleviate compacted soil is an expensive exercise and if trafficked within a few months, can be easily re-compacted. Thus, minimum tillage is prescribed. However, in the Australian cotton industry, where the Bollgard II® cotton variety is prevalently used, there is a requirement to cultivate post-harvest to destroy the pupae of *Heliothis* (*Helicoverpa* spp.) and therefore reduce the chance of resistance genetics forming in *Heliothis* (Deutscher, Wilson & Mensah 2005; Rust 1933). Cultivation to at least 10 cm destroys the exit tunnels of the moth forming from the pupae, and is currently the only successful management method.

As discussed in preceding sections, CTF systems have proved to be the most effective means by which to manage soil compaction (Radford et al. 2001; Yule and McGarry 2007; Tullberg et al. 2007; Tullberg 2010). Prior to further discussion, it is pertinent to identify that "SOILpak for Cotton Growers" (McKenzie 1998) provides a comprehensive discussion around managing soil compaction in the cotton system in relation to other system considerations, with CTF as a primary recommendation. Control traffic farming was developed in the 1990s as a way of dealing with compaction whereby traffic is limited to compacted tramlines to increase the yield and decrease soil compaction incidence in-field (Neale 2010). However, the adoption of CTF is severely restricted in Australia, even though extension of the benefits of such a system have been presented to farmers for over 20 years, including a 5 year long program to educate farmers on such (Tullberg, Yule & McGarry 2007). The main problem growers' face is machinery imported from North America and Europe arriving with ridged track widths, requiring the grower to seek aftermarket modification of the wheel-track. These modifications present a substantial upfront capital outlay and void the machine's warrantee, which more often than not leads to true CTF not being adopted (Tullberg et al. 2011). Growers need manufacturers to provide wheel-track optional extras, in the same way that various sensors and air-conditioning are provided, to allow matching of wheel-track without further capital outlay and voidance of warrantee. A further consideration wheel-track as a manufacturer option, as opposed to aftermarket, is maintenance of the machine's resell value. Adoption of CTF would likely

increase if such options were made available, but manufacturers are currently unlikely to begin the long innovation development process mentioned in Section 0 without considerable evidence of requirement for CTF from their major markets. To shorten the innovation process, the wealth of knowledge from growers and local manufactures in Australia, who have been modifying machines for 20 years, could be harnessed. However, communication between the Australian industry and large manufacturers would need to improve. This was highlighted by a progressive grower in the Narrabri / Moree region who held a meeting in Moree to discuss implications of the JD7760 close to its inception and presented his findings to a manufacture's annual conference but still could not get the message offshore (Narrabri JD7760 discussion forums, Pers. Comm. 2013). On the other hand, Neale (2010) compares the cost of modifying machinery to 3 m wheel-track in a grain system (usually between AUD\$5,000–\$30,000) and relates this to the potential gains to be made by limiting compaction in the field (based on a nominal AUD\$200/ha gain; see Table 1). On this basis, the expense is easily justifiable and likely to be recouped within a season, or within the first few seasons for an average farm, which was defined by Neale (2010) as 1,000–3,000 ha. Perhaps better communication and exemplification of this economic rationale would also see CTF adopted without having to battle manufactures innovation processes.

The work of Keller and Arvidsson (2004) demonstrates that soil compaction is a function of the imposed stress and the contact area of that stress, which indicates that tyre characteristics and wheel load can be manipulated to minimise the effect of machine traffic on soil productivity. Where CTF cannot be justified by a grower, then ensuring that the precompression stress of the soil is not exceeded by minimising wheel load should be the aim of management. However, this often requires the use of smaller machinery, or increasing the footprint of heavier machines using dual wheels and/or tandem axles. Precompression stress decreases as soil moisture increases, which means that growers would need to have a keen understanding of their soil strength and the relation of this to the precompression stress. The imposed stress of the machine is also required, which is why SoilFlex was developed by Keller et al. (2007) to allow practitioners to obtain such information. However, this system is still relatively complex. Thus, optimisation of soil traffic impact for growers not using true CTF and a simple means by which to do this is still required. Models such as Soil Flex (Keller et al. 2007) should not be ignored in this process, but simpler ways to employ them should be investigated.

## Australian grower perspective of the John Deere 7760

Given the rapid adoption of the JD7760 in Australia (inception 2008 and 70% industry adoption by the 2011/2012 season; Vanderstock, 2012) and the discussion concerning previous impacts that technological innovations have on farming systems, an initial perspective on the JD7760 from Australian cotton growers is provided here. This information helps address the paucity of direct information pertaining to the JD7760 and its impact on the cotton farming system. In doing this, the emphasis has been placed on collecting “rich” data (Kelly, Allan & Wilson 2009b; Tullberg et al. 2011) through a series of four face-to-face discussion forums held throughout the Australian cotton industry (New South Wales: Hillston, Warren and Narrabri; Queensland: Dalby and Goondiwindi). These forums focussed on four key discussion points: 1) Adoption of the technology; 2) Incorporation of the technology into the farming system; 3) Perceived and evident impacts of the technology; and, 4) Technical support and communication for the technology. Participants attended the forums at the end of the 2012/13 cotton season, with a total of 12 growers and 8 extension/industry representatives; only the perspectives of growers are presented here. While the sample population is small ( $N=12$ ), the geographical representation and the richness of the data afford rigour to the information, providing initial industry perspectives. Discussions lasted for approximately 140 min and, although facilitated in order to address the key discussion points, the content direction was largely driven by participants. Facilitators asked confirmatory or follow up questions, but were cognisant not to use a leading line of questioning. The discussions were all digitally recorded and transcribed for emerging theme analysis. A summary of grower perspectives is provided in Table 2.

Grower estimation of adoption by 2013 is >80% for all regions, except for Dalby, Qld, where growers were uncertain of adoption rate. However, a dealer suggested that 120 JD7760 machines had been introduced Australia in 2013. This rapid adoption is supported by ginning data (Table 3) that takes into account the proportion of the seasonal cotton pick arriving at the gin in round module form. Initial insights into adoption drivers interestingly suggest that these machines appear to have been adopted for system efficiencies, rather than for immediate productivity gains, which is commonly a driver of adoption (Kelly, Allan & Wilson 2009a). At a cost of approximately AUD\$750K, the JD7760 represents a substantial investment, which might have been considered an impediment to adoption, as was found by Bennett and Cattle (2013a) when looking at adoption of soil health management programs. They also found that landholders could not afford machinery costs and that this was the major economic impediment to managing soil health. However, Australian cotton growers obviously do not see capital investment and machinery cost as impeding adoption of the JD7760, which can be explained by John Deere having elucidated



the benefits of the machine to the agricultural system in a way that reduced the perceived risk of investment to growers (Bennett & Cattle 2013a; Guerin 1999). In this case, the major drivers for adoption appear to be foremost increased safety on farm (100%,  $N=12$ ) and then a combination of better effective capacity of the machine (67%,  $N=12$ , all forums), reduced workforce requirement (50%,  $N=12$ , 3/5 forums) and decreased management stress (42%,  $N=12$ , 4/5 forums) (Table 2). Furthermore, 92% of participants ( $N=12$ , all forums) directly discussed and agreed that increased productivity (i.e. decreased harvest costs – crop return considered equal irrespective of harvest system utilised) did not drive adoption, which supports growers actively considering benefits to the agricultural system in the decision to adopt.

Five years since inception of the JD7760 in the Australian cotton industry, the issues with incorporating the machine into the system were focussed mainly on machine improvements (Table 2). Issues with obtaining parts and accessing qualified mechanical expertise appropriate to the JD7760 were raised by 58% ( $N=12$ ) of growers, although this was only from two regions – Warren and Hillston, NSW. Those in Warren stated that this was due to qualified personnel relocating away from the region, while those in Hillston are more geographically displaced from the centre of the cotton industry and may find access to services limited (Bennett & Cattle 2013b). The price of module plastic wrap is seen to be decreasing profit per hectare (a latent impact), with growers only being able to obtain wrap from one manufacturer. The general comments from forums pertaining to this issue suggest that as an alternate source of wrap is developed (hopefully within Australia) that this issue will be addressed. Interestingly, only 25% of participants found the machine difficult to transport, while only one participant was having difficulty transporting round modules. This reflects the fact that the Australian industry has quickly adapted to address these issues. Whilst Houlahan (2012) has indicated that there are issues with transport of both the machine and the module, a concerted effort by the cotton industry to address interstate regulations and create a series of guidelines and options (Houlahan Pers. Comm. 2013) has effectively removed transport as an impact. However, it initially was considered impacting on the cotton system and needs to be considered for future innovations.

As far as directly discussed JD7760 impacts were concerned, the forums suggest that the machine has had an overwhelmingly positive effect on the cotton system (Table 2). As discussed above, there were some initial issues to do with ginning (Krajewski 2012a; Vanderstok 2012) and transport (Houlahan 2012), but these have been rapidly overcome. A third of participants agreed that the round modules have caused an increase in cotton contamination, which was also highlighted by (Krajewski 2012b). Furthermore, half of the participants found that soil compaction was an issue resulting from harvesting with the JD7760. Of note, those from Warren, NSW, had only recently (since 2012) been able to grow cotton, which meant that the JD7760 had not been used in this area for that long. Additionally, these participants indicated that the harvest was irregularly

dry and that compaction was potentially not observed because of this. Tullberg (2010) suggests that while compaction may not be seen on the surface, that soils are often traversed when the soil moisture in the subsoil is beyond or near the plastic limit, thus causing subsoil compaction; this may have occurred as a latent impact in Warren, but was not measured by any of the growers. Removing the influence of Warren participants on the impact of the JD7760 on soil compaction for this reason results in 80% (N=7) of participants indicating that increased soil compaction is an impact of the JD7760.

*Table 2. Summary of emerging themes for the discussion forums held in the Australian cotton industry ordered in terms of key discussion points. Total participants for the five forums was twelve (Freq., frequency; frequency of response N=12).*

<i>Emerging theme</i>	<i>Freq. of response (%)</i>	<i>Number of forums representing view (N=5)</i>
<i>Adoption of the technology</i>		
Contractors have influenced the adoption of JD7760	33	4
Reduction in harvest costs is not an adoption driver	92	5
The JD7760 eliminates the module builder and increases safety	100	5
Management stress is reduced by the JD7760	42	4
The Case IH Module Express did not meet needs compared to the JD7760	100	5
<i>Incorporation of the technology into the farming system</i>		
Cost of wrap per hectare is reducing bottom-line	67	3
Skilled operators are needed	33	2
Need to be more careful with module moisture	25	3
Parts can be hard to source	58	2
The JD7760 2012 model accumulator is too small	75	3
Moisture can be more easily controlled allowing higher moisture pick (Vomax moisture sensor a key support tool)	42	3
Machine electrics can cause machine downtime and much frustration	75	4
<i>Perceived and evident impacts of the technology</i>		
Increased effective capacity	67	5
Reduced need for seasonal workforce	50	3
Increased tillage requirement post-harvest	25	3
Soil compaction is an issue	50	5
Decreased workplace health and safety risk	100	5
Increased contamination of modules	33	2
<i>Technical support and communication for the technology</i>		
Machine dealers are providing adequate technical support	42	5
John Deere link system	33	3

*Table 3. Round cotton modules ginned by region and year since the 2008 inception of the John Deere 7760 on-board module builder picking system in Australia.  
(Data sourced from: Vanderstok, 2012)*

<i>Gin</i>	<i>Round modules ginned at season finish (%)</i>				
	<i>2008</i>	<i>2009</i>	<i>2010</i>	<i>2011</i>	<i>2012</i>
MacIntyre	0	0	0	41	62
Mungindi	-	0	26	29	73
Ashley	24	40	39	48	75
Wathagar	-	0	0	20	45
Moomin	0	0	0	28	69
Yarraman	-	-	-	0	26
Merah	0	0	0	0	34
Boggabri	0	0	0	24	38
Trangie	-	-	0	0	65
Hillston	0	0	0	57	74

## **Towards an informed decision making framework**

Whilst the decision to adopt the JD7760 cotton picking system is not in question, the rapidity of the adoption causes some concern for the agricultural system to be able to adapt in order to utilise the system optimally. Increasing the harvest rate in the cotton industry via the numerous innovations discussed throughout this review has shown that the system has always had both positive and negative influences bestowed upon it as a result of an innovation. Eliminating the negative impacts is not necessarily feasible. Instead, identifying these, prior to majority adoption, and putting in place adoption guidelines, agricultural system considerations, and/ or impact mitigation options to optimise the integration of an innovation into the agricultural system should be the focus. In the cotton industry, the harvesting machinery represents a significant investment and potential risk, so identifying possible impacts, both positive and negative, would be advantageous in making informed, whole system, decisions. Using a combination of the literature reviewed and the Australian grower perspective of the JD7760, we have proposed an initial impact framework (Figure 11). This framework is not inclusive of all potential impacts, but identifies major impacts that could help informed decision making.

In order to pre-empt concerning impacts of future innovations, it is proposed that a structured framework and analysis method be used. One potential option is an adaptation of a process called Hazard Analysis and Critical Control Point (HACCP) theory. HACCP is a well-known methodology widely used in the food industry to ensure high quality products with minimum health risks to food consumers (Commission & Commission 1997). In agriculture, HACCP approaches have been made to extend the food safety chain back onto farm (Toregeani-Mendes et al. 2011) and it has also been regarded as a potential tool to improve management and increase productivity (Knight 2009).

Banhazi and Black (2009) detailed the enormous amount of information available in Precision Livestock Farming (PLF) and described how farmers are unable to identify the practices that are the most important to adopt and how to apply them correctly. They suggested that in order to ensure that the best practices and systems are in place, it is important to establish a logical approach, such as the HACCP approach, which allows the identification and successful implementation of the relevant PLF technologies.

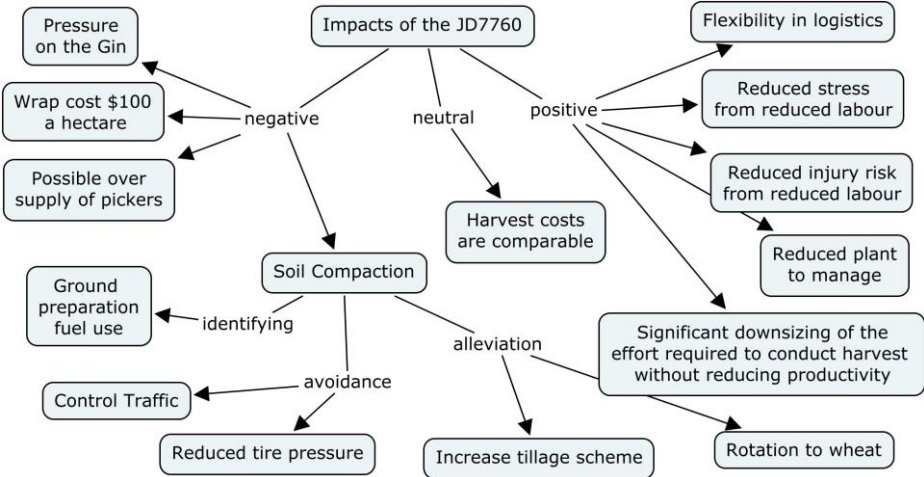

Figure 11. Summary of impacts of incorporating the John Deere 7760 on-board module building cotton picker into the Australian conventional cotton system drawn from the Australian perspective and literature.

To progress this concept further into a production perspective, Garmendia et al. (2013) details the use of critical control point theory to identify the Precision Agriculture (PA) technologies that are relevant to the sugarcane farming system, as well as possible constraints for farmers to adopt PA technologies. The process undertaken involves the implementation of seven principles: analyse hazards; determine critical control points (CCP) of such; establish limits for the CCPs; create a monitoring system to control the CCPs; establish corrective measures for any CCP not under control; establish the procedures to check the HACCP system is working; and, document the procedures used in the system. To provide an example for the cotton production system using soil compaction, the seven steps could correlate respectively to compaction; the factors of compaction; limits of the factors; methods to quantify the level of compaction and associate those to the factors; mitigation of compaction for a particular factor; regular soil testing; and, development of management options for compaction within the cotton industry (Garmendia, Jensen & Ballie 2013). The process could also be applied to individual whole-farm cotton producing systems to identify vulnerabilities within the system. These vulnerabilities could then be strengthened, or at the least acknowledge, to optimise the incorporation and impacts of subsequent technological innovations.

However, while this analysis process is useful in eliminating the reactive approach to system hazard analysis, it currently does not quantify the likelihood of a hazard occurring and the likely impact of effects of that hazard. Once again

using soil compaction as an example, Troldborg et al. (2013) have considered Bayesian belief networks (BBN) to determine the susceptibility of Scottish soils to soil compaction at a national level. BBNs are probabilistic models representing variables and their complex relationships. They are gaining increasing popularity for their ability to analyse complex systems, accommodating uncertainty and variability in modelled predictions due to the probabilistic approach (Henriksen et al. 2007; Uusitalo 2007). The beauty of the Bayesian approach in BBNs is that it addresses instances where empirical data are not available by utilising a mixture of both qualitative and quantitative data to strengthen outcomes and produce both diagnostic and predictive outcomes (Henriksen & Barlebo 2008). Troldborg et al. (2013) demonstrated that reasonable predictions could be made for susceptibility to soil compaction through the incorporation of existing empirical data, discrete data, derived data (e.g. pedotransfer functions) and expert knowledge. Where models normally seek to simplify the system through assumptions, the BBN approach captures the complexity of the system and explicitly accounts for uncertainties (Troldborg et al. 2013). The most important aspect to the approach is developing the network through determination of the variables and their relationships. Marcot et al. (2006) provide a general set of guidelines for a generic model structure, but as Troldborg et al. (2013) discuss it is initially important to determine a conceptual influence diagram representing the key drivers of the system of interest. They based this diagram on the generic model and relied upon author knowledge as well as external experts to build the network. For the cotton farming system, consultation between the grower, experts and BBN development team would be required. One way to simplify this would be to use HACCP to identify hazards and CCPS, which could form the basis of the network. This also provides a means to quantify the susceptibility of each hazard to change using the probabilistic predictive capability of the BBN.

Agricultural systems require a means by which to make informed decisions at a whole-farm/ system level for the adoption of innovative technology and its likely impact. We have provided a brief overview of JD7760 cotton picker impacts on the cotton system that could be further refined through structured analysis using an approach such as HACCP. It would be then pertinent to quantify the likelihood of impact using all available information at hand, while accounting for uncertainty. The BBN approach incorporated with HACCP could present a means by which to achieve this.

## Conclusion

This review has examined the impacts of increasing cotton harvest rate on the cotton system from the perspective of the machine, the environment and socioeconomics. Growers are driven by the need to perform more work with less labour, in a safe manner, and machines have offered this required increase in EC, amplifying their capacity to produce. However, as the system moves from one EC rate to another, impacts result that have been shown to always include some negative aspects. Learning to identify these impacts prior to mass adoption should be a focus of all industries. Australian cotton growers have embraced the JD7760 on the basis of clearly elucidated benefits to the agricultural system. John Deere's success in elucidating these benefits, highlights that large capital outlay can be overcome by clear communication. On the basis of understanding what the JD7760 offered the farming system, growers have actively worked with the industry to rapidly overcome associated issues within the cotton production system.

The bulk of impacts caused by the JD7760 cotton picker are perceived as positive, although the majority of growers picking cotton in regular seasons suggest that the JD7760 is impacting on soil compaction and that will need to be considered in managing the agricultural system into the future. Wheel loads for the JD7760 are concerning in terms of potential for irreversible soil compaction and limited research suggests that compaction is an issue throughout the soil profile. Soil compaction research in other industries has shown that lost production potential is significant and points towards the use of CTF systems where heavy wheel load and high clay content soils are required to interact. However, there are perceived financial restraints to adopting CTF in that it requires a large initial capital outlay. Either manufacturers need to provide further innovation to these machines in offering variable wheel-track options, which requires concerted communication from dominating machinery markets, or industry needs to clearly justify and demonstrate the benefits of CTF to the whole farming system to increase adoption. Where CTF is not adopted by growers, more simplified means of accounting for soil compaction impact would be of use to the grower in making decisions of when and where to traverse soils in order to alleviate the long term environmental and financial penalties of soil compaction.

Even though the impacts of the JD7760 on the cotton system in terms of transport and ginning have been rapidly identified and adjusted for a better option would be to identify these prior to mass adoption in order to have mitigation plans/ advice in place to minimise system negative impact. Such a framework would also help to demonstrate the benefits of CTF. The JD7760 has provided a useful case study in identifying this and there are potential solutions in the use of hazard analysis, identifying critical control points and providing estimates of hazard likelihood. Future research should focus on optimising whole

systems and providing useful tools for practitioners to take mitigation based action, rather than reaction.

## References

- Abeels, PFJ 1983, 'Determining the Feasibility of Mechanization in Agriculture', *European Journal of Mechanical and Environmental Engineering*, vol. 30, no. 1-2, pp. 27-32.
- ABS, ABoS 1993-94, *Agriculture, Australia*, <<http://www.abs.gov.au/AUSSTATS>>.
- ABS, ABoS 2003, *1301.0 - Year Book Australia* <<http://www.abs.gov.au/AUSSTATS>>.
- ABS, ABoS 2004, *1301.0 - Year Book Australia*, <<http://www.abs.gov.au/AUSSTATS>>.
- ABS, ABoS 2007, *1301.0 - Year Book Australia*, <<http://www.abs.gov.au/AUSSTATS>>.
- ABS, ABoS 2009-10, *1301.0 - Year Book Australia*, <<http://www.abs.gov.au/AUSSTATS>>.
- ABS, ABoS 2011-12, *7121.0 - Agricultural Commodities, Australia*, <<http://www.abs.gov.au/AUSSTATS>>.
- ABS, ABoS 2012, *1301.0 - Year Book Australia*, <<http://www.abs.gov.au/AUSSTATS>>.
- Ansorge, D & Godwin, RJ 2008, 'The effect of tyres and a rubber track at high axle loads on soil compaction-Part 2: Multi-axle machine studies', *Biosystems Engineering*, vol. 99, no. 3, pp. 338-47.
- Anthony, WS & Mayfield, WD 1995, *Cotton Ginners Handbook*, DIANE Publishing.
- Armijo, CB, Holt, GA, Baker, KD, Hughs, SE, Barnes, EM & Gillum, MN 2006, 'Harvesting and ginning a cotton with a fragile seed coat', *Journal of Cotton Science*, vol. 10, no. 4, pp. 311-8.
- Arvidsson, J 2001, 'Subsoil compaction caused by heavy sugarbeet harvesters in southern Sweden I. Soil physical properties and crop yield in six field experiments', *Soil and Tillage Research*, vol. 60, no. 1-2, pp. 67-78.
- Arvidsson, J, Sjöberg, E & Van Den Akker, JJH 2003, 'Subsoil compaction by heavy sugarbeet harvesters in southern Sweden III. Risk assessment using a soil water model', *Soil and Tillage Research*, vol. 73, no. 1-2, pp. 77-87.
- Arvidsson, J, Westlin, H, Keller, T & Gilbertsson, M 2011, 'Rubber track systems for conventional tractors - Effects on soil compaction and traction', *Soil and Tillage Research*, vol. 117, pp. 103-9.
- Baker, KD, Hughs, SE, McAlister, D & Mackey, J 2004, 'Quality of Spindle-Picked Cotton', in 2004 ASAE/CSAE Annual International Meeting, Ottawa, Ontario, Canada: *proceedings of the 2004 ASAE/CSAE Annual International Meeting, Ottawa, Ontario, Canada*.
- Bange, MP, Carberry, PS, Marshall, J & Milroy, SP 2005, 'Row configuration as a tool for managing rain-fed cotton systems: review and simulation analysis', *Australian Journal of Experimental Agriculture*, vol. 45, no. 1, pp. 65-77, viewed 2013/12/06/14:59:36, CSIRO Publishing.
- Banhazi, TM & Black, JL 2009, 'Precision livestock farming: a suite of electronic systems to ensure the application of best practice management on livestock farms', *Australian Journal of Multi-disciplinary Engineering*, vol. 7, no. 1, pp. 1-14, viewed 2013/12/12/04:28:17.
- Bennett, JM & Cattle, SR 2013a, 'Adoption of Soil Health Improvement Strategies by Australian Farmers: II. Impediments and Incentives', *The Journal of Agricultural Education and Extension*, no. ahead-of-print, pp. 1-25, viewed 2013/12/06/14:48:56.

- Bennett, JM & Cattle, SR 2013b, 'Adoption of Soil Health Improvement Strategies by Australian Farmers: I. Attitudes, Management and Extension Implications', *The Journal of Agricultural Education and Extension*, no. ahead-of-print, pp. 1-20, viewed 2013/12/06/14:47:30.
- Berisso, FE, Schjønning, P, Lamandé, M, Weisskopf, P, Stettler, M & Keller, T 2013, 'Effects of the stress field induced by a running tyre on the soil pore system', *Soil and Tillage Research*, vol. 131, pp. 36-46, viewed 2013/12/06/16:27:41, ScienceDirect.
- Botta, GF, Pozzolo, O, Bomben, M, Rosatto, H, Rivero, D, Ressia, M, Tourn, M, Soza, E & Vazquez, J 2007, 'Traffic alternatives for harvesting soybean (*Glycine max* L.): Effect on yields and soil under a direct sowing system', *Soil and Tillage Research*, vol. 96, no. 1-2, pp. 145-54, viewed 2013/12/12/02:54:42, ScienceDirect.
- Braunack, MV 2008, 'In-field harvest traffic - what impact on crop yield?', *Cropping Central*, no. 38.
- Braunack, MV 2012, 'Picker traffic and soil conditions', in *The 16th Australian Cotton Conference: proceedings of the The 16th Australian Cotton Conference Gold Coast*.
- Chamen, T, Alakukku, L, Pires, S, Sommer, C, Spoor, G, Tijink, F & Weisskopf, P 2003, 'Prevention strategies for field traffic-induced subsoil compaction: A review Part 2. Equipment and field practices', *Soil and Tillage Research*, vol. 73, no. 1-2, pp. 161-74.
- Chan, KY, Oates, A, Swan, AD, Hayes, RC, Dear, BS & Peoples, MB 2006, 'Agronomic consequences of tractor wheel compaction on a clay soil', *Soil and Tillage Research*, vol. 89, no. 1, pp. 13-21, viewed 2013/12/12/02:56:25.
- Chaudhry, MR 1997, 'Harvesting and ginning of cotton in the world', *Proc. of Beltwide Cotton Conf. 1997, New Orleans, LA, USA*, pp. 1617-9.
- Chen, G & Baillie, C 2009, 'Development of a framework and tool to assess on-farm energy uses of cotton production', *Energy Conversion and Management*, vol. 50, no. 5, pp. 1256-63.
- Columbus, EP, Bel, PD & Robert, KQ 1990, 'Maintaining cotton quality', *Transactions of the American Society of Agricultural Engineers*, vol. 33, no. 4, pp. 1057-65.
- Commission, CA & Commission, CA 1997, 'Hazard analysis and critical control point (HACCP) system and guidelines for its application', *Codex Alimentarius General Requirements (Food Hygiene), Supplement to*, vol. 1, pp. 19-26.
- Cotton and Wool Yearbook Data Sets*, 2010, Washington, DC, <<http://www.ers.usda.gov/data-products/cotton-and-wool-yearbook.aspx>>.
- Covington, MJ, Orsborn, JH, Dupire, FC, Hale, GH, Hargett, JR & Hood, KB 2003, *Method for building a cotton module on a mobile cotton harvester*, Case Corporation, 2003/03/11/, US6530199 B1.
- Danfors, B 1994, 'Changes in subsoil porosity caused by heavy vehicles', *Soil and Tillage Research*, vol. 29, no. 2, pp. 135-44, viewed 2013/12/06/15:04:56.
- Deere & Co 2006, *New John Deere 9976 and 9970 Pro Series Pickers: In a league all their own!*
- Deere & Co 2012, *7760 Cotton Picker (Export Edition)*. <[http://manuals.deere.com/omview/OMN406828\\_19/?tM=FR](http://manuals.deere.com/omview/OMN406828_19/?tM=FR)>.
- Defossez, P & Richard, G 2002, 'Models of soil compaction due to traffic and their evaluation', *Soil and Tillage Research*, vol. 67, no. 1, pp. 41-64, viewed 2013/12/06/15:05:24.
- Demmel, M, Brandhuber, R & Geischer, R 2008, 'Effects of heavy agricultural machines for sugar beet -harvesting on soil physical properties', pp. 6143-51.



- Deutsch, TA 1989, *Method and apparatus for compacting cotton within a cotton harvester basket*, Deere & Company, 1989/12/26/, US4888940 A.
- Deutsch, TA, Haverdink, VD & Pearson, ML 2001, *Cotton harvester with accumulator*, 6263650, Deere & Company, US, 2001/07/24/, <<http://www.google.com.au/patents?id=wPoGAAAAEBAJ>>.
- Deutscher, SA, Wilson, LJ & Mensah, RK (eds) 2005, *Integrated pest management guidelines for cotton production systems in Australia*, Australian Cotton CRC, Google Books, <<http://books.google.com.au/books?id=NGXaIQAACAAJ>>.
- Etana, A & Håkansson, I 1994, 'Swedish experiments on the persistence of subsoil compaction caused by vehicles with high axle load', *Soil and Tillage Research*, vol. 29, no. 2-3, pp. 167-72.
- Fachini, RM & Orsborn, JH 1985, *On board cotton module system for cotton harvesting machines*, 4553378, J. I. Case Company, US, 1985/11/19/, <<http://www.google.com.au/patents?id=dC04AAAAEBAJ>>.
- Flowers, MD & Lal, R 1998, 'Axle load and tillage effects on soil physical properties and soybean grain yield on a mollic ochraqualf in northwest Ohio', *Soil and Tillage Research*, vol. 48, no. 1-2, pp. 21-35.
- Fox, JR, Pearson, ML & Bares, RM 2009, *Cotton harvester chassis configuration*, Deere & Company, 2009/12/15/, US7631716 B2.
- Fragar, L & Temperley, J 2011, 'Drivers of adoption of safety innovations on Australian cotton farms', *Journal of Agricultural Safety and Health*, vol. 17, no. 3, pp. 209-26.
- Gameda, S, Raghavan, GSV, McKyes, E & Theriault, R 1987, 'Subsoil compaction in a clay soil. I. Cumulative effects', *Soil and Tillage Research*, vol. 10, no. 2, pp. 113-22.
- Gameda, S, Raghavan, GSV, McKyes, E, Watson, AK & Mehuys, G 1994, 'Long-term effects of a single incidence of high axle load compaction on a clay soil in Quebec', *Soil and Tillage Research*, vol. 29, no. 2-3, pp. 173-7.
- Garmendia, AG, Jensen, T & Ballie, C 2013, Use of a HACCP-like framework for Sugarcane production. Unpublished.
- Gola, JA, Basile, PA & Deutsch, TA 2000, *Densification method and apparatus for harvested cotton or other similar*, 6032446, Deere & Company, US, 2000/03/07/, <<http://www.google.com.au/patents?id=fr4DAAAAEBAJ>>.
- Grove, WA 2002, 'The economics of cotton harvest mechanization in the United States, 1920-1970', *The Journal of Economic History*, vol. 62, no. 2, pp. 545-9.
- Grove, WA & Heinicke, C 2003, 'Better opportunities or worse? The demise of cotton harvest labor, 1949-1964', *Journal of Economic History*, vol. 63, no. 3, pp. 736-67.
- Guérif, J 1984, 'The influence of water-content gradient and structure anisotropy on soil compressibility', *Journal of Agricultural Engineering Research*, vol. 29, no. 4, pp. 367-74, viewed 2013/12/06/16:37:05.
- Guerin, TF 1999, 'An Australian perspective on the constraints to the transfer and adoption of innovations in land management', *Environmental Conservation*, vol. 26, no. 4, pp. 289-304, viewed 2013/12/06/14:47:50.
- Gysi, M, Ott, A & Flühler, H 1999, 'Influence of single passes with high wheel load on a structured, unploughed sandy loam soil', *Soil and Tillage Research*, vol. 52, no. 3-4, pp. 141-51.
- Gysi, M, Klubertanz, G & Vulliet, L 2000, 'Compaction of an Eutric Cambisol under heavy wheel traffic in Switzerland — field data and modelling', *Soil and Tillage Research*, vol. 56, no. 3-4, pp. 117-29.
- Håkansson, I 1985, 'Swedish experiments on subsoil compaction by vehicles with high axle load', *Soil Use and Management*, vol. 1, no. 4, pp. 113-6,

- Håkansson, I, Voorhees, WB, Elonen, P, Raghavan, GSV, Lowery, B, Van Wijk, ALM, Rasmussen, K & Riley, H 1987, 'Effect of high axle-load traffic on subsoil compaction and crop yield in humid regions with annual freezing', *Soil and Tillage Research*, vol. 10, no. 3, pp. 259-68.
- Hamza, MA & Anderson, WK 2005, 'Soil compaction in cropping systems: A review of the nature, causes and possible solutions', *Soil and Tillage Research*, vol. 82, no. 2, pp. 121-45.
- Hazell, P & Wood, S 2008, 'Drivers of change in global agriculture', *Philosophical Transactions of the Royal Society B: Biological Sciences*, vol. 363, no. 1491, pp. 495-515,
- Heinicke, C & Grove, WA 2008, 'Machinery Has Completely Taken Over: The Diffusion of the Mechanical Cotton Picker, 1949-1964', *Journal of Interdisciplinary History*, vol. 39, no. 1, pp. 65-96,
- Henriksen, HJ & Barlebo, HC 2008, 'Reflections on the use of Bayesian belief networks for adaptive management', *Journal of Environmental Management*, vol. 88, no. 4, pp. 1025-36, viewed 2013/12/06/14:32:27.
- Henriksen, HJ, Rasmussen, P, Brandt, G, Von Buelow, D & Jensen, FV 2007, 'Public participation modelling using Bayesian networks in management of groundwater contamination', *Environmental Modelling & Software*, vol. 22, no. 8, pp. 1101-13, viewed 2013/12/06/14:32:48.
- Hettiaratchi, DRP 1987, 'A critical state soil mechanics model for agricultural soils', *Soil Use and Management*, vol. 3, no. 3, pp. 94-105, viewed 2013/12/06/16:37:18.
- Heuer, H, Tomanová, O, Koch, HJ & Märlander, B 2008, 'Subsoil properties and cereal growth as affected by a single pass of heavy machinery and two tillage systems on a Luvisol', *Journal of Plant Nutrition and Soil Science*, vol. 171, no. 4, pp. 580-90.
- Holley, D 2000, *The Second Great Emancipation: The Mechanical cotton picker, Black Migration and How They Shaped the Modern South*, The University of Arkansas Press.
- Holley, D 2003, *Mechanical Cotton Picker*.
- Horn, R, Taubner, H, Wuttke, M & Baumgartl, T 1994, 'Soil physical properties related to soil structure', *Soil and Tillage Research*, vol. 30, no. 2, pp. 187-216, viewed 2013/12/06/16:37:12.
- Houlahan 2012, 'Better module and picker transport', in The 16th Australian Cotton Conference: *proceedings of the The 16th Australian Cotton Conference Gold Coast*.
- Hughs, SE, Valco, TD & Williford, JR 2008, '100 Years of cotton production, harvesting, and ginning systems engine ering: 1907-2007', *Transactions of the ASABE*, vol. 51, no. 4, pp. 1187-98.
- Isbell, R 2002, *Australian Soil Classification*.
- IWG, WRB 2007, 'World reference base for soil resources 2006, first update 2007', *FAO, Rome*.
- Jensen, T, Powell, G & Neale, T 2001, 'Yield And Protein Variation Within A Controlled Traffic System', pp. 268-72, <<http://regional.org.au/au/asa/2001/1/a/neale.htm>>.
- Keeling, W, Johnson, J, Boman, R & Wanjura, J n. d., *Economic Comparison of Commercial Scale Stripper and Picker Harvest Systems In Texas South Plains*, Lubbock, Texas, <<http://lubbock.tamu.edu/files/2011/10/EconomicComparisonofStrippervsPickerHarvestsystems.pdf>>.
- Keller, T & Arvidsson, J 2004, 'Technical solutions to reduce the risk of subsoil compaction: effects of dual wheels, tandem wheels and tyre inflation pressure on

- stress propagation in soil', *Soil and Tillage Research*, vol. 79, no. 2, pp. 191-205, viewed 2013/11/28/03:24:50, ScienceDirect.
- Keller, T, Défossez, P, Weisskopf, P, Arvidsson, J & Richard, G 2007, 'SoilFlex: A model for prediction of soil stresses and soil compaction due to agricultural field traffic including a synthesis of analytical approaches', *Soil and Tillage Research*, vol. 93, no. 2, pp. 391-411, viewed 2013/11/28/03:24:46, ScienceDirect.
- Kelly, B, Allan, C & Wilson, BP 2009a, 'Soil indicators and their use by farmers in the Billabong Catchment, southern New South Wales', *Australian Journal of Soil Research*, vol. 47, pp. 234-42.
- Kelly, B, Allan, C & Wilson, BP 2009b, 'Corrigendum to: Soil indicators and their use by farmers in the Billabong Catchment, southern New South Wales', *Soil Research*, vol. 47, no. 3, pp. 340-, viewed 2013/12/06/14:49:52.
- Key, HA 1985, 'Cotton picker development and field performance', in Paper - American Society of Agricultural Engineers: *proceedings of thePaper - American Society of Agricultural Engineers*.
- Knight, C 2009, *HACCP in agriculture: a practical guide*, Campden and Chorleywood Food Research Association Group.
- Kocher, MF, Walker, JT, Matthews, EJ & Shackelford, PS 1989, 'Energy inputs to cotton production in Arkansas', *Applied Engineering in Agriculture*, vol. 5, no. 3, pp. 297-306.
- Krajewski, A 2012a, 'A non-invasive moisture measurement instrument for gins', in The 16th Australian Cotton Conference: *proceedings of theThe 16th Australian Cotton Conference* Gold Coast.
- Krajewski, A 2012b, 'Detecting (and removing) contaminants in ginning', in The 16th Australian Cotton Conference: *proceedings of theThe 16th Australian Cotton Conference* Gold Coast.
- Kulkarni, SS, Espinoza, L, Ismanov, M & Griffin, T 2008, 'Comparison of soil compaction patterns by on-board module builders', in Proceeding Beltwide Cotton Conference: *proceedings of theProceeding Beltwide Cotton Conference*.
- Kulkarni, SS, Espinoza, L, Griffin, T & Bajwa, SG 2010, 'Soil compaction patterns by conventional and on-board module builders'.
- Lal, R 1996, 'Axle load and tillage effects on crop yields on a Mollic Ochraqualf in Northwest Ohio', *Soil and Tillage Research*, vol. 37, no. 2-3, pp. 143-60.
- Lal, R & Ahmadi, M 2000, 'Axle load and tillage effects on crop yield for two soils in central Ohio', *Soil and Tillage Research*, vol. 54, no. 1-2, pp. 111-9,
- Larson, WE, Gupta, SC & Useche, RA 1980, 'Compression of agricultural soils from eight soil orders', *Soil Science Society of America Journal*, vol. 44, no. 3, pp. 450-7, viewed 2013/12/06/16:37:25.
- Laws, F 2008a, 'Economic Study: Module-Building Picker Savings Are Real, Intangible', *South West Farm Press*.
- Laws, F 2008b, 'Growers Compare Module-Building Cotton Pickers', *South West Farm Press*.
- Longoria, RG 2013, *Steering and Turning Vehicles - 2: Kinematic models of 2D steering and turning*, viewed 16 Novemeber 2013, <[http://www.me.utexas.edu/~longoria/VSDC/notes/05\\_Steering\\_and\\_Turning\\_Vehicles\\_pptx\\_p2.pdf](http://www.me.utexas.edu/~longoria/VSDC/notes/05_Steering_and_Turning_Vehicles_pptx_p2.pdf)>.
- Lowery, B & Schuler, RT 1991, 'Temporal effects of subsoil compaction on soil strength and plant growth', *Soil Science Society of America Journal*, vol. 55, no. 1, pp. 216-23.

- Mamster 2003, 'Capacity', <<http://www.caes.uga.edu/departments/bae/extension/handbook/documents/capacity.pdf>>
- Marcot, BG, Steventon, JD, Sutherland, GD & McCann, RK 2006, 'Guidelines for developing and updating Bayesian belief networks applied to ecological modeling and conservation', *Canadian Journal of Forest Research*, vol. 36, no. 12, pp. 3063-74, viewed 2013/12/06/14:20:45.
- McGarry, D 2003, 'Tillage and Soil Compaction', in L García-Torres, et al. (eds), *Conservation Agriculture*, Springer Netherlands, pp. 307-16.
- McKenzie, D 1998, 'SOILpak for cotton growers, 3rd edn. Orange', *New South Wales Agriculture*.
- McVeigh, A 2010, 'The New Round Module Picker... A Farmer's Perspective, Powerpoint Presentation', in The 15th Australian Cotton Conference: *proceedings of the 15th Australian Cotton Conference Gold Coast*, <<http://www.australiancottonconference.com.au/2010-Presnetations/mcveigh-adam>>.
- Musoke, MS & Olmstead, AL 1982, 'The rise of the cotton industry in California: a comparative perspective', *Journal of Economic History*, vol. 42, no. 2, pp. 385-412.
- Narayanan, SS 2005, 'Cotton harvesting improvements for yield, quality, economy and efficiency', *Asian Textile Journal*, vol. 14, no. 9, pp. 65-72.
- The cost of grain harvester compaction*, 2010, Created By.
- Nickla, LE 1965, *Cotton picker compactor*, Int Harvester Co, 1965/11/02/, US3215291 A.
- Nickla, LE 1968, *Cotton picker and cotton compactor therefor*, Int Harvester Co, 1968/11/26/, US3412532 A.
- O'Sullivan, MF, Henshall, JK & Dickson, JW 1999, 'A simplified method for estimating soil compaction', *Soil and Tillage Research*, vol. 49, no. 4, pp. 325-35, viewed 2013/12/05/14:07:30, ScienceDirect.
- Parvin, DW & Martin, SW 2005, 'The Effect of Recent and Futuristic Changes in Cotton Production Technology on Direct and Fixed Costs Per Acre, Mississippi, 2004', in Selected paper, Southern Agricultural Economics Association annual meeting: *proceedings of the Selected paper, Southern Agricultural Economics Association annual meeting*.
- Peterson, W & Kislev, Y 1986, 'The cotton harvester in retrospect: Labor displacement or replacement?', *Journal of Economic History*, vol. 46, no. 1, pp. 199-216
- Porter, WM, Wanjura, JD, Taylor, RK & Buser, MD 2012, 'Evaluating cotton stripper field performance', in American Society of Agricultural and Biological Engineers Annual International Meeting 2012: *proceedings of the American Society of Agricultural and Biological Engineers Annual International Meeting 2012* pp. 3579-86.
- Radford, BJ, Yule, DF, McGarry, D & Playford, C 2001, 'Crop responses to applied soil compaction and to compaction repair treatments', *Soil and Tillage Research*, vol. 61, no. 3, pp. 157-66, viewed 2013/12/12/02:56:55.
- Raghavan, GSV, McKyes, E, Gendron, G, Borglum, B & Le, HH 1978, 'Effects of soil compaction on development and yield of corn (maize)', *Canadian Journal of Plant Science*, vol. 58, no. 2, pp. 435-43.
- Raper, RL 2005, 'Agricultural traffic impacts on soil', *Journal of Terramechanics*, vol. 42, no. 3-4, pp. 259-80, ScienceDirect.
- Rembert, SS 1850, *Improvement in Picking Cotton from the Bolls in the Field*, 7631, US, 1850/09/10/, <<http://www.google.com.au/patents?id=UA1HAAAEBAJ>>.
- Renoll, E 1979, 'Using Farm Machinery Effectively', *Auburn University Agricultural Experiment Station Bulletin 510*.

- Riley, H 1994, 'The effect of traffic at high axle load on crop yields on a loam soil in Norway', *Soil and Tillage Research*, vol. 29, no. 2-3, pp. 211-4.
- Rust, JD 1933, *Cotton Picking Joachine*, 1894198, US, 1933/01/10/, <<http://www.google.com.au/patents?id=TXVBAAAAEBAJ>>.
- Schäfer-Landefeld, L, Brandhuber, R, Fenner, S, Koch, HJ & Stockfisch, N 2004, 'Effects of agricultural machinery with high axle load on soil properties of normally managed fields', *Soil and Tillage Research*, vol. 75, no. 1, pp. 75-86.
- Silverthorne, MW 1919, *Portable combined cotton picking*, 1919/08/26/, US1314437 A.
- Spoor, G, Tijink, FGJ & Weisskopf, P 2003, 'Subsoil compaction: Risk, avoidance, identification and alleviation', *Soil and Tillage Research*, vol. 73, no. 1-2, pp. 175-82.
- Street, JH 1955, 'Cotton Mechanization and Economic Development', *The American Economic Review*, vol. 45, no. 4, pp. 566-83.
- Toregeani-Mendes, KA, Arroiteia, CC, Kimmelmeier, C, Dalpasquale, VA, Bando, É, Alves, AF, Marques, OJ, Nishiyama, P, Mossini, SAG & Machinski, M 2011, 'Application of hazard analysis critical control points system for the control of aflatoxins in the Brazilian groundnut-based food industry', *International Journal of Food Science & Technology*, vol. 46, no. 12, pp. 2611-8, viewed 2013/12/12/04:36:20.
- Troldborg, M, Aalders, I, Towers, W, Hallett, PD, McKenzie, BM, Bengough, AG, Lilly, A, Ball, BC & Hough, RL 2013, 'Application of Bayesian Belief Networks to quantify and map areas at risk to soil threats: Using soil compaction as an example', *Soil and Tillage Research*, vol. 132, pp. 56-68, viewed 2013/12/06/14:33:22.
- Tullberg, J 2010, 'Tillage, traffic and sustainability—A challenge for ISTRO', *Soil and Tillage Research*, vol. 111, no. 1, pp. 26-32, viewed 2013/12/06/14:08:24, ScienceDirect.
- Tullberg, J, McHugh, A, Ghareel Khabbaz, B, Scheer, C & Grace, P 2011, 'Controlled traffic/permanent bed farming reduces GHG emissions', pp. 1-4, <<http://eprints.usq.edu.au/19778>>.
- Tullberg, JN, Yule, DF & McGarry, D 2007, 'Controlled traffic farming—from research to adoption in Australia', *Soil and Tillage Research*, vol. 97, no. 2, pp. 272-81, viewed 2013/12/09/08:31:45.
- Uusitalo, L 2007, 'Advantages and challenges of Bayesian networks in environmental modelling', *Ecological modelling*, vol. 203, no. 3, pp. 312-8, viewed 2013/12/06/14:33:04.
- Van den Akker, JJH & Soane, B 2005, 'Compaction', *HILLEL, D. et al. Encyclopedia of soils in the environment. New York: Academic*, vol. 1, pp. 285-93.
- Vanderstok, A 2012, 'Better Ginning of Round Bales', in *The 16th Australian Cotton Conference: proceedings of the The 16th Australian Cotton Conference Gold Coast*.
- Viaud, J 1990, *Baling machine for forming cylindrical bales of crop*, Deere & Company, 1990/04/10/, US4914900 A.
- Vickers, N 1999, 'The Share Cropping System', <<http://www.clt.astate.edu/sarahwf/elainrt/sharcrnv2.htm>>
- Voorhees, WB 1986, 'Deep compaction: a different phenomenon', *Crops and soils magazine*, vol. 40.
- Wagon, FM 1956, *TRAVELLING COMBINATION COTTON STRIPPING*, 1956/09//, 2,763,117.
- Walsh, P 2002, 'New mehtod yields a worm's eye view', *Farming Ahead*, no. 132, pp. 16-8.
- Wattonville, JD 2008, '7760 Cotton Picker', <<http://elibrary.asabe.org/newresults.asp>>.

- Willcutt, H 2011, 'New cotton harvesters benefit growers', *Resource: Engineering and Technology for Sustainable World*, vol. 18, no. 5, pp. 22-3.
- Wilkes, LH & Wilkes, LH 1973, *Seed Cotton Handling Apparatus*, 3749003, US, 1973/07/03/, <<http://www.google.com.au/patents?id=feJ8AAAAEBAJ>>.
- Willcutt, H & Barnes, E 2008, 'Fuel consumption in spindle picker cotton harvesting systems', in *Proceedings of the Beltwide Cotton Conferences: proceedings of the Beltwide Cotton Conferences*.
- Willcutt, MH, Buschermohle, MJ, Barnes, E & To, F 2009, 'In field time in motion comparisons of conventional, John Deere 7760, and Case 625 Module Express cotton pickers', in *Beltwide Cotton Conference: proceedings of the Beltwide Cotton Conference*.
- Willcutt, MH, Buschermohle, MJ, Huitink, GW, Barnes, EM, Wanjura, JD & Searcy, SW 2010, *The Spindle Type Cotton Harvester*, <<http://lubbock.tamu.edu/files/2011/11/CottonSpindle10August2010FINAL.pdf>>.
- Williford, JR, Meredith Jr, WR & Anthony, WS 1986, 'Factors influencing yield and quality of delta cotton', in *Paper - American Society of Agricultural Engineers: proceedings of the Paper - American Society of Agricultural Engineers*.
- Wood, RK, Reeder, RC, Morgan, MT & Holmes, RG 1993, 'Soil physical properties as affected by grain cart traffic', *Transactions - American Society of Agricultural Engineers*, vol. 36, no. 1, pp. 11-5.